

CALIFORNIA FOREST PRACTICE RULES 2002

*Title 14, California Code of Regulations
Chapters 4, 4.5 and 10*

with the
Z'BERG-NEJEDLY FOREST PRACTICE ACT,
the
WILD AND SCENIC RIVERS ACT,
the
PROFESSIONAL FORESTERS LAW and REGISTRATION OF PROFESSIONAL
FORESTERS RULES,
and with information related to
FOREST ROADBED MATERIALS

Prepared for:

California Licensed Timber Operators
and California Registered Professional Foresters

Compiled by:

The California Department of Forestry and Fire Protection
Resource Management, Forest Practice Program
P.O. Box 944246
Sacramento, CA 94244-2460

See Also, CDF Web Site's Home Page, at www.fire.ca.gov

Gray Davis
Governor
State of California

Mary D. Nichols
Secretary for Resources
The Resources Agency

Andrea E. Tuttle
Director
California Department of Forestry
and Fire Protection

January 2002 Version
First Printing

READ THIS FIRST !!!!

HOW TO USE THIS BOOK

Sections 895 through 909.1 and 1020 through 1115.3 apply Statewide.

Coast District	Sections 911 thru 929.7
Northern District	Sections 931 thru 949.7
Southern District	Sections 951 thru 969.7

Look in the *Table of Contents* for your subject. For example, under Harvesting Practices & Erosion Control, Felling Practices begins on Page 53. All Forest Districts are listed: 914.1, 934.1, 954.1, thus the rule that applies to your operation is the same for all three Districts.

Skim through the table to find rules that are unique to only one or two of the Districts. For example: 954.4 Site Preparation Addendum applies only in the Southern District.

Both the rules that apply in all districts and those specific to any one district would apply in that particular district. You will need to locate all those rules that apply to the district where you work.

Please Note: The underlined sections of the rules are those that were adopted, corrected or amended since the 2001 edition of this rulebook. The double underlined sections of the rules are those that were adopted, corrected or amended and apply only to those plans approved after July 1, 2000 pursuant PRC § 4554.5, amended by Stats.1999, c. 582 (S.B.621), § 1. Editorial comments are included in brackets and italicized (i.e. [*and Fire Protection*]). New editorial comments are included in brackets and underlined and italicized (i.e., [*and Fire Protection*]).

CDF HOME PAGE ON THE INTERNET

CDF has a Web Site and Home Page on the Internet: www.fire.ca.gov. Copies of the 2002 Rules, and associated forms can be accessed in: www.fire.ca.gov/resourcemanagement/forestpractice.asp. The 2002 version uses Microsoft® Word 2000 as well as Adobe Acrobat PDF format. Instructions on how to use the Adobe PDF format are on the web site; an Adobe Acrobat Viewer must be installed on your computer.

DISCLAIMER

This presentation of the Forest Practice Rules is intended to provide field personnel with working rules for their use. It is not intended to be authoritative. The official web site for any California law or rule is www.leginfo.ca.gov/calaw.html. In addition, the Office of Administrative Law maintains their web site of the California Code of Regulations at <http://ccr.oal.ca.gov>. The only official publication of the rules is by:

Barclays Official California Code of Regulations

P. O. Box 3066
South San Francisco, CA 94083
Telephone: 1-800-888-3600

The California Department of Forestry and Fire Protection has benefited from the observations of readers who have cited errors in earlier editions. Your comments in that area are appreciated.

TABLE OF CONTENTS

CALIFORNIA FOREST PRACTICE RULES

Title 14, California Code of Regulations, Chapter 4,

SUBCHAPTER 1 ABBREVIATION AND DEFINITIONS..... 1

Article 1 Abbreviations and Definitions 1

 895 Abbreviations Applicable Throughout Chapter 1

 895.1. Definitions 3

**CONFIDENTIAL ARCHAEOLOGICAL ADDENDUM FOR TIMBER OPERATIONS ON
NON-FEDERAL LANDS IN CALIFORNIA 20**

SUBCHAPTER 2 APPLICATION OF FOREST PRACTICE RULES 24

Article 1 Introduction 24

 896 General 24

 897 Implementation of Act Intent 24

Article 2 Preparation and Review of Timber Harvesting Plans 26

 898 Feasibility Alternatives 26

 898.1 Review of Plan by Director 26

 898.2 Special Conditions Requiring Disapproval of Plans 27

Article 3 PRC 4555, Rule Review Procedures 28

 900 Intent 28

 901 Timber Harvesting Plan Decision Delay 28

 902 Director's Notice to Board 28

 902.1 Board Action 28

 902.2 Notice Content 28

 902.3 Notice Distribution 28

 903.1 Content of Discussion and Prejudice of Appeal 29

 903.2 Board Action 29

SUBCHAPTER 3 FOREST DISTRICT BOUNDARIES 29

Article 1 Districts 29

 906 Forest Districts 29

 907 Coast Forest District 29

 908 Northern Forest District 30

 909 Southern Forest District 30

 909.1 High Use Subdistrict 30

SUBCHAPTERS 4, 5 & 6 FOREST DISTRICT RULES 30

Article 1 Introduction 30

 911, 931, 951 Statement of Purpose 30

Article 2 Ratings and Standards 30

 912.5 Procedure for Estimating Surface Soil Erosion Hazard Rating [Coast] 30

 932.5, 952.5 Procedure for Estimating Surface Soil Erosion Hazard Rating [Northern, Southern] 31

 912.7, 932.7, 952.7 Resource Conservation Standards for Minimum Stocking 31

TABLE OF CONTENTS

912.8 Progeny, Clonal, or Provenance Testing Stocking Standard Exemption [Coast only].....	32
912.9, 932.9, 952.9 Cumulative Impacts Assessment Checklist	33
BOARD OF FORESTRY TECHNICAL RULE ADDENDUM NO. 2.....	34
CUMULATIVE IMPACTS ASSESSMENT	34
Article 3 Silvicultural Methods	41
913, 933, 953 Silvicultural Objectives	41
913.1, 933.1, 953.1 Regeneration Methods Used in Evenaged Management	41
913.2, 933.2, 953.2 Regeneration Methods Used in Unevenaged Management	44
913.3, 933.3, 953.3 Intermediate Treatments	46
913.4, 933.4, 953.4 Special Prescriptions	47
913.5, 933.5, 953.5 Stocking Status.....	48
913.6, 933.6, 953.6 Alternative Prescriptions	48
913.7, 933.7 Exceptions [Coast, Northern]	49
953.7 Riparian Vegetation [Southern].....	49
953.8 Exceptions [Southern].....	49
913.8 Special Harvesting Methods for Southern Subdistrict [Coast]	49
953.9 Successive Cutting [Southern only].....	51
913.10, 933.10, 953.10 Timberland Productivity, Sustained Forestry Planning, Addendum	51
913.11, 933.11, 953.11 Maximum Sustained Production of High Quality Timber Products	52
953.12 High Use Subdistrict.....	53
Article 4 Harvesting Practices and Erosion Control	53
914, 934, 954 Purposes	53
914.1, 934.1, 954.1 Felling Practices.....	53
914.2, 934.2, 954.2 Tractor Operations.....	53
914.3, 934.3, 954.3 Cable Yarding.....	55
954.4 Site Preparation Addendum [Southern only]	55
914.5, 934.5, 954.5 Servicing of Logging Equipment, Disposal of Refuse, Litter, Trash and Debris	55
914.6, 934.6, 954.6 Waterbreaks.....	55
914.7, 934.7, 954.7 Timber Operations, Winter Period.....	57
914.8, 934.8, 954.8 Tractor Road Watercourse Crossing	57
914.9, 934.9, 954.9 Alternatives to Standard Rules.....	58
Article 5 Site Preparation	58
915, 935, 955 Purposes	58
915.1, 935.1, 955.1 Use of Heavy Equipment for Site Preparation	58
915.2, 935.2, 955.2 Treatment of Vegetative Matter	58
915.3, 935.3, 955.3 Protection of Natural Resources.....	59
915.4, 935.4, 955.4 Site Preparation Addendum	59

TABLE OF CONTENTS

Article 6 Water Course and Lake Protection	59
916, 936, 956 Intent of Watercourse and Lake Protection	59
916.1, 936.1, 956.1 In Lieu Practices	60
916.2, 936.2, 956.2 Protection of the Beneficial Uses of Water <u>and Riparian Functions</u>	60
916.3, 936.3, 956.3 General Limitations Near Watercourses, Lakes, Marshes, Meadows and Other Wet Areas	61
916.4, 936.4, 956.4 Watercourse and Lake Protection	61
916.5, 936.5, 956.5 Procedure for Determining Watercourse and Lake Protection Zone (WLPZ) Widths and Protective Measures	63
916.5, 936.5, 956.5 Procedures for Determining Watercourse and Lake Protection Zone Widths and Protective Measures	65
916.6, 936.6, 956.6 Alternative Watercourse and Lake Protection	66
916.7, 936.7, 956.7 Reduction of Soil Loss	66
916.8, 936.8, 956.8 Sensitive Watersheds	67
<u>916.9, 936.9, 956.9 Protection and Restoration in Watersheds with Threatened or Impaired Values</u>	69
916.10, 936.10, 956.10 Domestic Water Supply Protection	73
<u>916.11, 936.11, 956.11 Effectiveness and Implementation Monitoring</u>	73
<u>916.12, 936.12, 956.12 Section 303(d) Listed Watersheds</u>	74
Article 7 Hazard Reduction	74
917, 937, 957 Hazard Reduction	74
917.2, 937.2, 957.2 Treatment of Slash to Reduce Fire Hazard	74
917.3 Prescribed Broadcast Burning of Slash [Coast]	75
937.3 Prescribed Broadcast Burning of Slash [Northern]	75
957.3 Prescribed Broadcast Burning of Slash [Southern]	75
917.4 Treatment of Logging Slash in the Southern Subdistrict	75
957.4 Treatment of Logging Slash in the High Use Subdistrict	76
917.5, 937.5, 957.5 Burning of Piles and Concentrations of Slash	76
917.6, 937.6, 957.6 Notification of Burning	76
917.7, 937.7, 957.7 Protection of Residual Trees	76
917.9, 937.9, 957.9 Prevention Practices	77
BOARD OF FORESTRY TECHNICAL RULE ADDENDUM NO. 3	77
917.10, 937.10, 957.10 Locating and Reporting	78
Article 8 Fire Protection	78
918, 938, 958 Fire Protection [Coast, Northern, Southern]	78
918.1, 938.1, 958.1 Fire Suppression Resource Inventory	78
918.3, 938.3, 958.3 Roads to be Kept Passable	78
918.4, 938.4, 958.4 Smoking and Matches	78
918.5, 938.5, 958.5 Lunch and Warming Fires	79
918.6, 938.6, 958.6 Posting Procedures	79
918.7, 938.7, 958.7 Blasting and Welding	79
918.8, 938.8, 958.8 Inspection for Fire	79
918.10, 938.10, 958.10 Cable Blocks	79
Article 9 Wildlife Protection Practices	79
919, 939, 959 Wildlife Practice	79
919.1, 939.1, 959.1 Snag Retention	79
919.2, 939.2, 959.2 General Protection of Nest Sites	80
919.3, 939.3, 959.3 Specific Requirements for Protection of Nest Sites	80
919.4, 939.4, 959.4 Non-listed Species	82
919.5, 939.5, 959.5 Alternatives	82
919.9, 939.9 Northern Spotted Owl [Coast, Northern]	82

TABLE OF CONTENTS

919.10, 939.10 Take of Northern Spotted Owl [Coast, Northern]	84
919.11 Marbled Murrelet Protective Measures [Coast]	85
919.12, 939.12, 959.12 Sensitive Species Classification	85
939.15 Protection of Wildlife Habitat [Northern]	86
959.15 Protection of Wildlife Habitat [Southern]	86
919.16, 939.16, 959.16 Late Succession Forest Stands	86
 Article 10 Violations of Rules Prior to Changes	 87
920, 940, 960 Violations of Rules Prior to Changes	87
 Article 11 Coastal Commission Special Treatment Areas	 87
921, 961 Coastal Commission Special Treatment Areas [Coast, Southern, Special Treatment Area].....	87
921.1 Preliminary Field Work and Timber Harvesting Plans [Coast, Special Treatment Area]	87
961.1 Preliminary Field Work and Timber Harvesting Plans [Southern, Special Treatment Area]	88
921.2 Exemptions from Timber Harvesting Plan Requirements [Coast, Special Treatment Area]	88
961.2 Exemptions from Timber Harvesting Plan Requirements [Southern, Special Treatment Area]	89
921.3 Silvicultural Methods [Coast, Special Treatment Area]	89
961.3 Silvicultural Methods [Southern, Special Treatment Area]	90
921.4, 961.4 Stocking Requirements [Coast, Southern, STA]	91
921.5 Logging Practices [Coast, Special Treatment Area]	92
961.5 Logging Practices [Southern, Special Treatment Area]	92
921.6 Hazard Reduction [Coast, Special Treatment Area]	93
961.6 Hazard Reduction [C.C. Special Treatment Area]	93
921.7 Watercourse and Lake Protection [C.C. Special Treatment]	93
961.7 Watercourse and Lake Protection [Southern, Special Treatment Area]	94
921.8 Buffer Zones Within the Coastal Zone [Coastal Zone]	94
961.8 Buffer Zones Within the Coastal Zone [CZ, Southern]	94
921.9 Alternatives [Coast, CZ]	94
 Article 12 Logging Roads and Landings	 94
923, 943, 963 Logging Roads and Landings	94
923.1, 943.1, 963.1 Planning for Roads and Landings	95
923.2, 943.2, 963.2 Road Construction	96
923.3, 943.3, 963.3 Watercourse Crossings	97
923.4, 943.4, 963.4 Road Maintenance	98
923.5, 943.5, 963.5 Landing Construction	99
923.6, 943.6, 963.6 Conduct of Operations on Roads and Landings	100
923.7, 943.7, 963.7 Licensed Timber Operator Responsibility for Roads and Landings	100
923.8, 943.8, 963.8 Planned Abandonment of Roads, Watercourse Crossings, and Landings	100
<u>923.9, 943.9, 963.9 Roads and Landings in Watersheds with Threatened or Impaired Values</u>	100
 Article 13 County Rules	 101
924 County Rules Within the Southern Subdistrict of the Coast Forest District [Coast, SSD]	101
924.1 Plan Submittal and Notice of Intent [Coast, SSD]	101
924.2 Plan Filing [Coast, SSD]	102
924.3 Preharvest Inspection [Coast, SSD]	102
924.4 Notice of Filing [Coast, SSD]	102
924.5 Agency and Public Review [Coast, SSD]	102
 COUNTY RULES, COAST DISTRICT	 102
925 Santa Clara County Rules [Santa Clara County]	102
925.1 Winter Period [Santa Clara County]	102
925.2 Plan Submittal and Notice of Intent [Santa Clara County]	102

TABLE OF CONTENTS

925.3 Plan Distribution [Santa Clara County]	103
925.4 Contents of the Plan [Santa Clara County]	103
925.5 Tractor Yarding [Santa Clara County]	103
925.6 Flagging [Santa Clara County]	103
925.7 Log Hauling [Santa Clara County]	104
925.8 Public Road Buffer Zone [Santa Clara County]	104
925.9 Public Road Protection [Santa Clara County]	104
925.10 Hours of Work [Santa Clara County]	104
925.11 Performance Bonding [Santa Clara County]	104
926 Santa Cruz County Rules [Santa Cruz County]	105
926.1 Registered Professional Forester (RPF) Advice [Santa Cruz County]	105
926.2 Field Review and Timber Operator Certification [Santa Cruz County]	105
926.3 Plan Submittal and Notice of Intent [Santa Cruz County]	105
926.4 Preharvest Inspection Report [Santa Cruz County]	107
926.5 Additional Information After Preharvest Inspection [Santa Cruz County]	107
926.6 Public Water Agency Representative [Santa Cruz County]	107
926.7 Review Team Field Review [Santa Cruz County]	107
926.8 Fuelwood Operations [Santa Cruz County]	107
926.9 Hours of Work [Santa Cruz County]	108
926.10 Log Hauling [Santa Cruz County]	108
926.11 Flagging of Property Lines [Santa Cruz County]	108
926.12 Soil [Santa Cruz County]	108
926.13 Performance Bonding [Santa Cruz County]	108
926.14 Biotic Resources [Santa Cruz County]	109
926.15 Road Construction [Santa Cruz County]	109
926.16 Flagging [Santa Cruz County]	109
926.17 Abandonment of Roads and Landings [Santa Cruz County]	109
926.18 Winter Period [Santa Cruz County]	109
926.19 Erosion Control Maintenance [Santa Cruz County]	109
926.21 Exemptions From Timber Harvesting Plan Requirements [Santa Cruz County]	110
926.23 Contents of Plan [Santa Cruz County]	110
926.25 Special Harvesting Methods [Santa Cruz County]	111
927 Marin County Rules [Marin County]	111
927.1 Winter Period [Marin County]	111
927.2 Contents of Plan [Marin County]	111
927.3 Tractor Yarding [Marin County]	112
927.4 Flagging [Marin County]	112
927.5 Log Hauling [Marin County]	112
927.6 Public Road Buffer Zone [Marin County]	113
927.7 Timber Harvesting Plans [Marin County]	113
927.8 Exemptions from Timber Harvesting Plan Requirements [Marin County]	113
927.9 Silvicultural Methods and Intermediate Treatments [Marin County]	113
927.10 Stocking Requirements [Marin County]	114
927.11 Logging Practices [Marin County]	115
927.12 Hazard Reduction [Marin County]	115
927.13 Buffer Zones Within the CRC [Marin County]	116
927.14 Notice of Intent and Filing [Marin County]	116
927.15 Review Team Meetings [Marin County]	116
927.16 Registered Professional Forester (RPF) Advice [Marin County]	116
927.17 Decisions on Winter Operations [Marin County]	116
928 San Mateo County Rules [San Mateo County]	116
928.1 Definitions [San Mateo County]	116
928.2 Contents of Plan [San Mateo County]	117
928.3 Flagging [San Mateo County]	117
928.4 Performance Bonding [San Mateo County]	117
928.5 Hours of Work [San Mateo County]	117

TABLE OF CONTENTS

928.6 Log Hauling [San Mateo County] 118
928.7 Cutting Practices [San Mateo County] 118

COUNTY RULES, NORTHERN DISTRICT 118

945 Lake County Rules [Lake County] 118
945.1 Statement of Purpose [Lake County] 118
945.2 Definitions [Lake County] 118
945.3 Timber Harvest Prescriptions [Lake County] 119
945.4 Hours of Operation [Lake County] 119
945.5 Exempt and Emergency Notice Operations [Lake County] 119

COUNTY RULES, SOUTHERN DISTRICT 120

965 Monterey County Rules [Monterey County] 120
965.1 Haul Routes [Monterey County] 120
965.2 Hauling to the Nearest Public Road [Monterey County] 120
965.3 Public Road Protection [Monterey County] 120
965.4 Log Hauling [Monterey County] 120
965.5 Winter Period [Monterey County] 120
965.6 Big Sur Coast [Monterey County] 120
965.7 Public Water Agency Representative [Monterey County] 121
965.8 Performance Bonding [Monterey County] 121
965.9 Erosion Control Maintenance [Monterey County] 121
965.10 THP Description [Monterey County] 122

Article 14 Archaeological and Historical Resource Protection 122

929, 949, 969 Statement of Purpose 122
929.1, 949.1, 969.1 Plan, and Emergency Notice Preparation 122
929.2, 949.2, 969.2 Protection Measures for THPs and Emergency Notices 3 Acres and Larger 125
929.3, 949.3, 969.3 Post Review Site Discovery 125
929.4, 949.4, 969.4 Archaeological Training Requirements 125
929.5, 949.5, 969.5 Site Recording 126
929.6, 949.6, 969.6 Protection of Sites During Timber Operations 126
929.7, 949.7, 969.7 Determination of Significance 126

SUBCHAPTER 7 ADMINISTRATION 126

Article 1 Timber Operator Licenses 126

1020 Board Authority Delegated 126
1022 License 127
1022.1 Limited Timber Operator License 127
1022.2 License for Site Preparation 127
1022.3 License for Erosion Control Maintenance 127
1023 Issuance of License 127
1023.1 Company, Corporation and Partnership Licenses 127
1024 Application Form and Content 127
1024.1 Timber Operator Education 128
1024.2 Qualifying Experience 128
1024.3 Application Processing 128
1024.4 Returned Checks 128
1024.5 Insurance Maintenance 128
1025 Fees for Licenses 128
1026 License Renewal 129
1027 License Denial 129
1027.1 Basis of Denial 129
1027.2 Partnership and Corporation Denials 129

TABLE OF CONTENTS

1027.3 Multiple Licenses	129
1029 License Availability	129
1030 Change of Address.....	129
Article 2 Timber Harvesting Plan.....	130
1032 Timber Harvesting Plan Filing Locations	130
1032.7 Plan Submittal and Notice of Intent.....	130
1032.8 Notice of Intent-Distribution by Director	131
1032.9 Request for Notification of Timber Harvesting Plan Submission	131
1032.10 Request for Information on Domestic Water Supplies	131
1033 Filing Date.....	132
1034 Contents of Plan.....	132
1034.2 Professional Judgment	134
1035 Plan Submitter Responsibility	134
1035.1 Registered Professional Forester Responsibility.....	135
1035.2 Interaction Between RPF and LTO	136
1035.3 Licensed Timber Operator Responsibilities.....	136
1035.4 Notification of Commencement of Operations.....	137
1036 Deviations	137
1036.1 Murrelet Protection before Notice of Completion	137
1037 THP Preharvest Inspection-Filing Return	137
1037.1 Notice of Filing.....	137
1037.3 Agency and Public Review.....	138
1037.4 Director's Determination	138
1037.5 Review Teams to be Established	138
1037.6 Nonconformance of Plan.....	140
1037.7 Conformance of Plan.....	140
1037.8 Notice of Conformance.....	140
1037.9 Public Inspection	140
1037.10 Review Period Waiver.....	140
1037.11 Notice of Waiver	141
1038 Exemption	141
BOARD OF FORESTRY TECHNICAL RULE ADDENDUM NO. 4:.....	144
ILLUSTRATION OF MINIMUM DISTANCES REQUIRED BY LAW FOR FIRE SAFE THP	
VEGETATION TREATMENT	Error! Bookmark not defined.
BOARD OF FORESTRY TECHNICAL RULE ADDENDUM NO. 4:.....	Error! Bookmark not defined.
ILLUSTRATION OF REMOVAL OF LADDER FUELS AND HORIZONTAL CONTINUITY OF	
FUELS	Error! Bookmark not defined.
1038.1 Compliance with Act and Rules	146
1038.2 Exemption Form.....	146
1038.3 Agency Exemptions	146
1039 Amendment.....	146
1039.1 Effective Period of the Plan	146
1040 Report Minor Deviations	147
1041 Limitations	147
1042 Change of Ownership.....	147
1043 Cancellation of Plans.....	147

TABLE OF CONTENTS

1045 Director Delegation 147

1050 Erosion Control Maintenance 147

1051 Modified THP 148

1051.1 Contents of Modified THP 149

1051.2 Review of Modified THP 149

1052 Emergency Notice 149

1052.1 Emergency Conditions 150

1052.2 Emergency Substantiated by RPF 150

1052.3 Emergency Notice For Insect Damaged Timberlands 151

Article 3 Timber Harvesting Plan Appeal Procedures 151

1053 Purpose of Regulations 151

1054 Return of Plan by Director 151

1054.1 Right to Request Public Hearing 151

1054.2 Form of Request for Hearing 151

1054.3 Filing of Request for Hearing 151

1054.4 Public Hearing 152

1054.5 Notice of Hearing 152

1054.6 Hearing Record 152

1054.7 Hearing Procedures 152

1054.8 Order of the Board 152

1055 County Appeals Procedures 153

1055.1 Hearing on County Appeal 153

1055.2 County Appeal Hearing Procedures-Scheduling 153

1055.3 County Appeal Hearing Procedures-Notice 153

1055.4 County Appeal Hearing Procedures-Record 154

1055.5 County Appeal Hearing Procedures-Sequence 154

1055.6 County Appeal Hearing Procedure-Order 154

1056 Head of Agency Appeals Procedure 155

1056.1 Hearing on Head of Agency Appeal 155

1056.2 Head of Agency Appeal Hearing Procedures-Scheduling 155

1056.3 Head of Agency Appeal Procedures-Notice 155

1056.4 Head of Agency Appeal Hearing Procedures-Record 156

1056.5 Head of Agency Appeal Hearing Procedures-Sequence 156

1056.6 Head of Agency Appeal Hearing Procedures-Order 156

Article 3.2 Administrative Penalty Hearing Procedures 157

1057 Purpose of Regulations 157

1057.1 Filing of Petition and Notice of Defense/Request for Hearing 157

1057.2 Failure to Request Hearing 157

1057.3 Hearing Procedures 157

1057.4 Administrative Record 157

1057.5 Petition and Notice of Defense/Request for Hearing Form 158

1058 Hearing Procedures-Notice 159

1058.1 Hearing Procedures-Recording and Transcription 159

1058.2 Hearing Procedures-Use of Board Hearing Procedure and Sequence 159

1058.3 Hearing Procedures-Determination 159

1058.4 Review of Proposed Decision and Findings of Fact 160

1058.5 Determination 160

1059 Infractions 160

TABLE OF CONTENTS

Article 4 Timber Site Classification	161
1060 Site Classification	161
Article 5 Standardized Stocking Sampling Procedures	162
1070 Stocking Sampling	162
1071 Minimum Stocking Standards	162
1072 Stocking Sampling Procedures	162
1072.1 Number of Plots Required	162
1072.2 Plot Layout	163
1072.3 Equipment	163
1072.4 Exclusions	163
1072.5 Basal Area Stocking Sampling Procedure	163
1072.6 Point Count Stocking Sampling Procedure	163
1072.7 Combination Stocking Sampling Procedure	164
1073 Unacceptable Results	164
1074 Waiver Request	165
1074.1 Waiver Approval	165
1075 Report of Stocking	166
Article 6 Stocking Standards for Substantially Damaged Timberlands	166
1080 Substantially Damaged Timberlands	166
1080.1 Stocking Requirements for Substantially Damaged Timberlands	166
1080.2 Timber Harvesting Plans for Substantially Damaged Timberlands	166
1080.3 Stocking Distribution	166
1080.4 Stocking Reports for Substantially Damaged Timberlands	167
1080.5 Time Period to Meet Stocking Requirements	167
Article 6.5 Nonindustrial Timber Management Plan Administration	167
1090 Rule Application	167
1090.1 Timber Management Plan and Notice of Timber Operations Filing Locations	167
1090.2 NTMP Submittal and Notice of Preparation	167
1090.3 Notice of Preparation-Distribution by Director	168
1090.4 Request for Notification of NTMP or Notice of Timber Operations Submission	168
1090.5 Contents of NTMP	168
1090.6 Notice of Timber Operations	170
1090.7 Notice of Timber Operations Content	170
1090.8 NTMP Professional Judgment	171
1090.9 Plan Submitter Responsibility	171
1090.10 Registered Professional Forester Responsibility	172
1090.11 Interaction Between RPF and LTO on Notice of Timber Operations	172
1090.12 Licensed Timber Operator Responsibilities	172
1090.13 Notification of Commencement of Operations	173
1090.14 NTMP Deviations	173
1090.16 Notice NTMP of Filing	173
1090.17 Agency and Public Review for the NTMP	174
1090.18 Director's Determination	174
1090.19 Review Teams to be Established to Review Timber Management Plan	174
1090.20 Nonconformance of NTMP	174

TABLE OF CONTENTS

1090.21	Conformance of NTMP	174
1090.22	Notice of Conformance of the NTMP	174
1090.23	Public Inspection	174
1090.24	Amendment	175
1090.25	Report Minor Deviations	175
1090.26	Change of Ownership	175
1090.27	Cancellation of Plans	175
 Article 6.75 Sustained Yield Plan		175
1091.1	Sustained Yield Plan	175
1091.2	Relation to THPs	176
1091.3	Definitions	176
1091.4	Sustained Yield Plan Contents	176
1091.4.5	Sustained Timber Production Assessment	176
1091.5	Fish and Wildlife Assessment	177
1091.6	Watershed Assessment and Planning	177
1091.7	Limitation on Information Requirements	178
1091.8	Compliance and Effectiveness Evaluation	178
1091.9	SYP Effective Period	178
1091.10	Review of Sustained Yield Plan (SYP)	179
1091.11	Appeals	179
1091.12	Emergency Departures from SYP	179
1091.13	Amendments	180
1091.14	Timber Harvest Plans Submitted Within a SYP Management Unit	180
 Article 6.8 Program EIR and THP		180
1092	Rule Application	180
1092.1	PTEIR and PTHP	180
1092.2	Director's Guidance for Review of PTEIR	181
1092.3	Program Timber Harvesting Plan Filing Locations	181
1092.4	Program Timber Harvesting Plan (PTHP) Submittal	181
1092.5	Notice of Intent Distribution	182
1092.6	Request for Notification of PTHP Submission	182
1092.7	Request for Information on Domestic Water Supplies	182
1092.8	Filing Date	182
1092.9	PTHP Contents	182
1092.10	PTHP Professional Judgment	184
1092.11	PTHP Submitter Responsibility	184
1092.12	Registered Professional Forester Responsibility	185
1092.13	Interaction Between RPF and LTO on the PTHP	186
1092.14	Licensed Timber Operator Responsibilities	186
1092.15	Notification of Commencement of Operations	187
1092.16	PTHP Review Inspection-Filing Return	187
1092.17	Notice of PTHP Filing	187
1092.18	Agency and public Review for the PTHP	187
1092.19	Time Periods for Review	187
1092.20	Director's guidance for review of PTHP	188
1092.21	Special Conditions Requiring Disapproval of a PTHP	188
1092.22	Nonconformance of PTHP	188
1092.23	Conformance of PTHP	188
1092.24	Notice of Conformance of the PTHP	189
1092.25	Public Inspection	189
1092.26	Amendment	189
1092.27	Report Minor Deviations	189

TABLE OF CONTENTS

1092.28	Effective Period of the PTHP and PTEIR	190
1092.29	Change of Ownership	190
1092.30	Cancellation of PTHP	190
1092.31	Appeals	190
1092.32	Interim Measures for Maximum Sustained Production	191
Article 7 Conversion of Timberland		191
1100	Definitions	191
1101	Purpose	192
1102	Authority Delegated to Director	192
1103	Conversion of Timberland	192
1103.1	Prohibited Activity	192
1103.2	Public Records	192
1104	Operations Requiring Conversion Permit	192
1104.1	Conversion Exemptions	192
1104.2	Exemption for Conversion of Non-TPZ Land for Subdivision Development	197
1104.3	Timberland Conversion Permit Fees	198
1105	Application	198
1105.1	Application Fees	198
1105.2	Director's Determination	198
1105.3	Conversion Plan	198
1105.4	Additional Proof	199
1106	Conversion Permit Issuance	199
1106.1	Contents of Conversion Permit	199
1106.2	Timber Harvesting Plan Processing	199
1106.3	Recordation, Renewal, Transferability	199
1106.4	Conversion Permit Denial	199
1106.5	Denial, Suspension, Revocation	200
1107	Cancellation by Permittee	200
1108	Coastal Zone Conversion	200
1109	Immediate Rezoning	200
1109.1	City or County Tentative Approval	200
1109.2	Public Interest	201
1109.3	No Substantial and Unmitigated Adverse Effect Upon Other Timberland Production Zones Within One Mile (1.609 km)	201
1109.4	Suitability of Soils, Slopes, and Watersheds	201
1109.5	No Other Reasonable or Comparable Timber Growing Use	201
1109.6	Supplemental Data and Opinions	201
1110	Conversion Permit Within TPZ Not Required	201
CHAPTER 4.5 Hearings [in Rule Counties]		202
1115	Time for Request	202
1115.1	Scheduling	202
1115.2	Notification	202
1115.3	Conduct of Hearing	202

CALIFORNIA FOREST PRACTICE RULES

**CALIFORNIA FOREST PRACTICE RULES 2002
Title 14, California Code of Regulations, Chapter 4,**

SUBCHAPTER 1 ABBREVIATIONS AND DEFINITIONS

Article 1 Abbreviations and Definitions

895 Abbreviations Applicable Throughout Chapter

The following abbreviations are applicable throughout this chapter:

B & M	Baseline and Meridian reference lines running in true EW and NS directions used in U.S. General Land Survey
CAA	Confidential Archaeological Addendum
CAL	Confidential Archaeological Letter
CCR	California Code of Regulations
<u>CDF</u>	<u>California Department of Forestry and Fire Protection</u>
CEQA	California Environmental Quality Act (Public Resources Code Section 21000 et seq.)
cm	Centimeter(s)
dbh	The average diameter of a tree measured outside bark, at breast height, a point 4.5 feet (1.37 m) above the average ground level.
def.	Definition
<u>DFG</u>	<u>California Department of Fish and Game</u>
E	true cardinal direction East
EIR	Environmental Impact Report as defined in Public Resources Code Section 21061
F&GC	Fish and Game Code
FPA	Z'berg-Nejedly Forest Practice act of 1973 and amendments thereto (Public Resources Code Section 4551 et seq.)
ft	foot or feet
Gov. C.	Government Code
H	Humboldt (used in combination with B & M)
ha.	hectare(s)
<u>HCP</u>	<u>Habitat Conservation Plan</u>
in.	inch or inches

CALIFORNIA FOREST PRACTICE RULES

LTO	Licensed Timber Operator
m	Meter or meters
MD	Mount Diablo (used in combination with B & M)
MTHP	Modified Timber Harvest Plan
N	true cardinal direction North
NAHC	Native American Heritage Commission
<u>NMES</u>	<u>National Marine Fisheries Service</u>
NTMP	Nonindustrial Timber Management Plan
PRC	Public Resources Code
PTEIR	Program Timberland Environmental Impact Report
PTHP	Program Timber Harvesting Plan
R	Range: a row of townships, six miles in width, between two successive meridian lines of the U.S. General Land Survey.
ref.	Refer, reference
RPF	Registered Professional Forester
<u>RWQCB</u>	<u>Regional Water Quality Control Board</u>
S	true cardinal direction South
SB	San Bernardino (used in combination with B & M)
Sec.	Section
T	Township: a tier of ranges, six miles in length between two successive standard parallels as used in the U.S. General Land Survey.
THP	Timber Harvesting Plan
TPZ	Timberland Production Zone (Ref. Government Code Section 51104(g))
USGS	United States Geological Survey
W	true cardinal direction West
WLPZ	Watercourse and Lake Protection Zone

CALIFORNIA FOREST PRACTICE RULES

895.1. Definitions

The definitions contained in the Z'berg-Nejedly Forest Practice Act of 1973 as amended (commencing with Section 4511 of the Public Resources Code) shall apply to this chapter, as well as the following definitions, unless the context clearly requires otherwise.

Abandonment means leaving a logging road reasonably impassable to standard production four wheel-drive highway vehicles, and leaving a logging road and landings, in a condition which provides for long-term functioning of erosion controls with little or no continuing maintenance.

Act means the Z'berg-Nejedly Forest Practice Act of 1973 as currently amended (commencing with Section 4511 of the Public Resources Code).

Active Nest means a bird nest site at which breeding efforts have recently occurred as determined by the Department of Fish and Game, as specified below:

For the Great Blue Heron, Great Egret, recently means within the last two years.

For the Golden Eagle, Osprey, Goshawk, recently means within the last three years.

For the Bald Eagle and Peregrine Falcon, recently means within the last five years.

Nests that have not been used within this time period are considered abandoned.

Adequate Site Occupancy means the range of stocking levels which provide a balance between the largest number of trees per acre capable of maximum individual tree growth on future crop trees and maximum overall stand growth. This balance is achieved when stocking levels are within Zones 2 and 3 of the Langsaeter curve, as shown in "The Practice of Silviculture", by David Smith (1962).

Alternative Prescription means a written analysis of preharvest and postharvest timber stand conditions and a description of the silvicultural practices and systems to be used in lieu of the standard methods.

Approved and legally permitted structure means, for the purposes of 14 CCR 1038(d), only structures that are designed for human occupancy and garages, barns, stables, and structures used to enclose fuel tanks.

Archaeological Coverage Map means the map or maps required as part of a Confidential Archaeological Addendum or a Confidential Archaeological Letter pursuant to 14 CCR Section 929.1 [949.1,969.1] and 1052(d). The map(s) shall contain a north arrow, a scale, and accurately display the project boundary, the site survey area (showing survey intensity(ies)), and specific location of all archaeological and historical sites identified within the site survey area. The map(s) must be on a 1:1 scale copy of a USGS 7.5' quadrangle(s), or digitally generated topographical equivalent. Additional maps at other scales may be included to more accurately display required information or increase clarity.

Average Slope means the arithmetic average of a sample of slopes taken systematically over the area to which the average is to be applied.

Bankfull stage means the stage that occurs when discharge fills the entire channel cross section without significant inundation of the adjacent floodplain, and has a recurrence interval of 1.5 to 2.0 years.

Basal Area Per Acre see 4528(a).

Beneficial Functions of Riparian Zone means the specific role of the riparian zone to provide protection for water temperature control, streambed and flow modification by large woody debris, filtration of organic and inorganic material, upslope stability, bank and channel stabilization and vegetative structure diversity for fish and wildlife habitat.

Beneficial Use means those uses of water as defined by Section 13050(f) of the Water Code and as described in the applicable Water Quality Control Plan.

Berm means a curb or dike constructed to control water and prevent roadway runoff waters from discharging onto roadside slopes and/or to provide material for subsequent road maintenance.

Board see PRC 4521.3. [NOTE: Board of Forestry and Fire Protection]

Broadcast Burning means the use of fire throughout a site preparation area to prepare it for regeneration. It does not include burning of organic matter which is piled during mechanical site preparation or for hazard reduction.

Brood Material as used in these rules refers to any cut or downed portion of a tree's stem greater than three inches with intact undeteriorated bark.

CALIFORNIA FOREST PRACTICE RULES

Buffer Zone means the area of protection surrounding a nest tree in which timber operations must be conducted in accordance with the provisions set forth in these regulations. A buffer zone does not constitute a special treatment area.

Cable Roads means the path followed by logs being yarded by a cable system.

Cable Yarding means that system of skidding (transporting) logs by means of cable (wire rope) to the yarding machine (yarder) or a landing while the yarder remains stationary.

Canopy means the more or less continuous cover of branches and foliage formed collectively by the crowns of adjacent trees and other woody species.

Channel zone means that area that includes a watercourse's channel at bankfull stage and a watercourse's floodplain, encompassing the area between the watercourse transition lines.

Coastal Commission Special Treatment Area: (For the Coast Forest District:) means an identifiable and geographically bounded forest area designated within the Coastal Zone that constitutes a significant wildlife and/or plant habitat area, area of special scenic significance, and any land where timber operations could adversely affect public recreation areas or the biological productivity of any wetland, estuary, or stream especially valuable because of its role in a coastal ecosystem¹ (Ref.: Sec. 31118.5, PRC).

¹ All Coastal Commission Special Treatment Areas were adopted by the Coastal Commission on July 5, 1977, and they include several specially identified areas, buffer zones adjacent to designated highways within Coastal Scenic View Corridors, and buffer zone adjacent to publicly owned preserves and recreation areas. Maps or designations of Coastal Commission Special Treatment Areas are on file in Department offices in the Coast Forest District. Coastal Commission Special Treatment Areas have been designated according to the following criteria:

- A. Scenic View Corridors,
- B. Sites of significant scenic value,
- C. Wetlands, lagoons, streams, estuaries, and marine environments,
- D. Significant animal and plant habitat areas,
- E. Recreation areas.

The Coastal Commission has also set forth in its designations special management objectives considered essential by the Coastal Commission for the protection of public values within the Coastal Zone. The following is a listing of the Coastal Commission Special Treatment Areas. In parentheses following the name of each area are capital letters indicating the specific criteria as listed above. The letters referencing the criteria are listed in order of priority of the significance of the various criteria applicable to the area.

(a) Del Norte County: Elk Creek Valley (C), Sitka Spruce Grove (D,A), False Klamath Cove (B,A), Klamath River (B,A,C).

(b) Humboldt County: Freshwater Lagoon (B,C,E), Stone Lagoon (A,B,C,E), Big Lagoon (A,C,B), Big Lagoon Bog (B,C,E), Agate Beach Bluff (B,A), Mattole River (B,C). The King Range National Conservation Area forestlands that parallel the beach: All private inholdings that are within view of the beach trail that are in the recreational zoned western slopes.

(c) Mendocino County: Usal Creek (A,C), Rockport Beach (B), Hardy Creek Knoll (B), Westport (B), Ten Mile River (B,C), Noyo River (A,B,C), Casper and Doyle Creeks (A), Big River (A,B,C,E), Albion River (A,B,C,D), Navarro River (B,C,A), Navarro to Irish Beach Terrace (A,B), Elk Creek (C,B), Gualala River (B,C).

(d) Sonoma County: Gualala River (B,C), Sea Ranch Area (A), Stewarts Point Area (A), Horseshoe Cove Area (C,B,E), Stockoff Creek and Kolmer Gulch (B,C,D), Fort Ross (A,B), Mill Gulch (A,B), Timber Gulch (A,B), Russian Gulch (A), Sawmill Gulch (A), Sheephouse Creek (A,C,D), Duncan Mills Marsh (A,C,D), South Side of the Russian River (A,B,C,D,E), Willow Creek Headwaters (C,D), Jenner Gulch (C,D), Slaughterhouse Gulch(A,D), Furlong Gulch (A,D), Scotty Creek (C,D), Rough Creek (C,D).

(e) San Mateo County: San Pedro Valley (A), South Montara Mountain (A,B), Butano Panorama (B,E), Ano Nuevo Uplands (A,B,E).

(f) Santa Cruz County: Ano Nuevo Uplands (A,B,E), Waddell Creek (A,B,C,E), Bonny Doon Botanic Area (B,D), Molino Creek (A,B).

(g) Buffer Zones within Coastal Scenic View Corridors in Del Norte, Humboldt and Mendocino Counties.

(Footnote continues at footnote section of next page)

CALIFORNIA FOREST PRACTICE RULES

Coastal Commission Special Treatment Area: (For the Southern Forest District:) An identifiable and geographically bounded forest area designated within the Coastal Zone that constitutes a significant wildlife and/or plant habitat area, area of special scenic significance, and any land where timber operations could adversely affect public recreation areas or the biological productivity of any wetland, estuary, or stream especially valuable because of its role in the coastal ecosystem. Special treatment areas were adopted by the Coastal Commission on July 5, 1977. Maps or designations of "Coastal Commission Special Treatment Areas" are on file in the Department offices within the Southern Forest District.² (Ref. Sec. 31118.5, PRC)..

Codominants means trees with crowns forming the general level of the forest canopy and receiving full light from above, but comparatively little light from the sides. Codominants usually have medium sized crowns, but are crowded on the sides.

Footnote continued from previous page:

¹(1) Del Norte County. Highway 101 from Crescent City to Smith River town along the west side of the highway.

(2) Humboldt County.

(A) Highway 101 from the Moonstone-Westhaven Exit to Big Lagoon Bridge along both sides of the highway.

(B) Old Highway 101 from Trinidad north to Patrick's Point State Park entrance along both sides of the road.

(g) (3) Mendocino County. Highway 1 from Ten Mile River to Sonoma County line along both sides of the highway.

(h) Buffer Zones adjacent to all publicly owned preserves and recreation areas, including national, state, regional, county, and municipal parks.

² Coastal Commission Special Treatment Areas have been designated according to the following criteria:

A. Scenic View Corridors

B. Sites of Significant Scenic Value

C. Wetlands, Lagoons, Streams, Estuaries, and Marine Environments

D. Significant Animal and Plant Habitat Areas

E. Recreation Areas

The Coastal Commission has also set forth in its designations special management objectives considered essential by the Coastal Commission for the protection of public values within the Coastal Zone.

The following is a listing of the Coastal Commission Special Treatment Areas. In parentheses following the name of each area are capital letters indicating the specific criteria as listed above. The letters referencing the criteria are listed in order of priority of the significance of the various criteria applicable to the area.

(a) Monterey County. Del Monte Forest (A,B,D,E), Pt. Lobos Uplands (A,B,D), Malpaso Creek (B), Doud Creek (B), False Sur (B), Little Sur (A,B,C,E), Molera Uplands (A,B,C,E), Big Sur Valley (A,B,C,E), Sycamore Canyon (A), Post Creek (A,B,C,E), Grimes Canyon (A), Torea Canyon (B), Partington Canyon (B,E) McWay Canyon (B), Anderson Canyon (A,B), Burns Creek (A), Hot Springs Canyon (B,E), Lucia Area Canyonmouths (B,E), Mill Creek (B,E).

(b) San Luis Obispo County. Cambria Monterey Pines (A,B).

(c) Publicly Owned Preserves and Recreation Areas. Coastal Commission Special Treatment Areas include those forested areas within the Coastal Zone within 200 ft. (60.96 m) of an publicly owned preserved and recreation areas including national, state, regional, county, and municipal parks.

CALIFORNIA FOREST PRACTICE RULES

Commercial Species (For the Coast Forest District:) means those species found in group A and those in group B that are found on lands where the species in Group A are now growing naturally or have grown naturally in the recorded past.

Group A:

- Coast Redwood (*Sequoia sempervirens*)
- Douglas Fir (*Pseudotsuga menziesii*)
- Grand Fir (*Abies grandis*)
- Western Hemlock (*Tsuga heterophylla*)
- Western Redcedar (*Thuja plicata*)
- Bishop Pine (*Pinus muricata*)
- Monterey Pine (*Pinus radiata*)
- Sitka Spruce (*Picea sitchensis*)
- Incense Cedar (*Libocedrus decurrens*)
- Port Orford Cedar (*Chamaecyparis lawsoniana*)
- California Red Fir (*Abies magnifica*)
- White Fir (*Abies concolor*)
- Jeffrey Pine (*Pinus jeffreyi*)
- Ponderosa Pine (*Pinus ponderosa*)
- Sugar Pine (*Pinus lambertiana*)
- Western White Pine (*Pinus monticola*)

Group B:

- Tanoak (*Lithocarpus densiflorus*)
- Red Alder (*Alnus rubra*)
- White Alder (*Alnus rhombifolia*)
- Eucalyptus (*Eucalyptus species*)
- Pacific Madrone (*Arbutus menziesii*)
- Golden Chinkapin (*Castanopsis chrysophylla*)
- Pepperwood (*Umbellularia californica*)
- Oregon White Oak (*Quercus garryana*)
- California Black Oak (*Quercus kelloggii*)

Commercial species (For the Northern Forest District:) means those species found in group A and those in group B that are found on lands where the species in group A are now growing naturally or have grown naturally in the recorded past.

Group A:

- Sugar Pine (*Pinus lambertiana*)
- Coast Redwood (*Sequoia sempervirens*)
- Ponderosa Pine (*Pinus ponderosa*)
- Jeffrey Pine (*Pinus jeffreyi*)
- Western White Pine (*Pinus monticola*)
- Lodgepole Pine (*Pinus contorta*)
- White Fir (*Abies concolor*)
- California Red Fir (*Abies magnifica*)
- Noble Fir (*Abies procera*)
- Douglas Fir (*Pseudotsuga menziesii*)
- Incense-Cedar (*Libocedrus decurrens*)
- Port Orford Cedar (*Chamaecyparis lawsoniana*)

Group B:

- Knobcone Pine (*Pinus attenuata*)
- Digger Pine (*Pinus sabiniana*)
- California Black Oak (*Quercus kelloggii*)
- Oregon White Oak (*Quercus garryana*)
- Tanoak (*Lithocarpus densiflorus*)
- Mountain Hemlock (*Tsuga mertensiana*)
- Brewer Spruce (*Picea breweriana*)
- Englemann Spruce (*Picea engelmannii*)
- Sierra Redwood (*Sequoiadendron giganteum*)
- Golden Chinkapin (*Castanopsis chrysophylla*)
- Foxtail Pine (*Pinus balfouriana*)
- White Alder (*Alnus rhombifolia*)
- Monterey Pine (*Pinus radiata*)
- Pacific Madrone (*Arbutus menziesii*)
- California Laurel (*Umbellularia californica*)
- Western Juniper (*Juniperus occidentalis*)

Commercial Species (For the Southern Forest District:) means those species found in group A and those in group B that are found on lands where the species in group A are now growing naturally or have grown naturally in the recorded past.

Group A:

- Coulter Pine (*Pinus coulteri*)
- Jeffrey Pine (*Pinus jeffreyi*)
- Ponderosa Pine (*Pinus ponderosa*)
- Sugar Pine (*Pinus lambertiana*)
- Lodgepole Pine (*Pinus contorta*)
- Monterey Pine (*Pinus radiata*)
- Western White Pine (*Pinus monticola*)
- Douglas-Fir (*Pseudotsuga menziesii*)
- California Red Fir (*Abies magnifica*)
- White Fir (*Abies concolor*)
- Incense Cedar (*Libocedrus decurrens*)
- Coast Redwood (*Sequoia sempervirens*)
- Sierra Redwood (*Sequoiadendron giganteum*)
- Mountain Hemlock (*Tsuga mertensiana*)

CALIFORNIA FOREST PRACTICE RULES

Group B:

-White Alder (*Alnus rhombifolia*)
-Cottonwood (*Populus fremontii*)
-Eucalyptus (*Eucalyptus sp.*)

-Pacific Madrone (*Arbutus menziesii*)
-California Black Oak (*Quercus kelloggii*)
-Tanoak (*Lithocarpus densiflorus*)

Committee see PRC 4522.

Community Fuelbreak Area means a shaded fuelbreak approved by a public fire agency as part of a fire prevention plan for fire protection, ignition management, prefire management or other fire defense improvements. Within a shaded fuelbreak, vegetation is managed to reduce the potential for wildfire damage and provides a direct benefit to defensible space as defined in 14 CCR 1271. Community fuelbreak areas include defensible space areas within 200 feet of approved and legally permitted structures, as defined in 14 CCR 895.1, and those areas comprising systems of fuelbreaks that are designed or approved by a public fire agency as part of a fire prevention plan.

Compatible Use means uses which do not significantly detract from the use of the property for, or inhibit, growing and harvesting timber, and shall include those specified in Government Code 51104(h) unless in specific instances such use would be contrary to this definition.

Concentration means an accumulation of slash, limbs, tops, slabs or other logging debris that exceeds 30 inches (76.2 cm) in height above the ground and covers more than 100 square feet (9.29 m/sq) of surface area except that individual logs not associated with other logging debris which exceed these dimensions shall not be considered a concentration of slash or logging debris.

Confidential Archaeological Addendum means the archaeological and historical resources survey and impact assessment prepared for a proposed timber operation pursuant to the rules. It is submitted on a form entitled "CDF Confidential Archaeological Addendum for Timber Operations on Non-Federal Lands in California" dated 1/1/98 (or an equivalent) and is confidential to the extent permitted pursuant to Government Code Sections 6254(r) and 6254.10. It is not included in any document provided to the public. It contains all information required by 14 CCR 929.1, 929.2, 929.3, 929.7, 949.1, 949.2, 949.3, 949.7, 969.1, 969.2, 969.3, 969.7. **(Copy of the form found at the end of the Definitions section)**

Confidential Archaeological Letter means the archaeological and historical resources survey and impact assessment prepared for an Emergency Notice covering three acres or more in size. It is included with the submittal of the Emergency Notice to the Director and contains all information required by 14 CCR Section 929.1 [949.1,969.1], including site records, if required pursuant to 929.1 [949.1,969.1] (f). The information may be presented on the form entitled "CDF Confidential Archaeological Addendum for Timber Operations on Non-Federal Lands in California" dated 1/1/98 (or an equivalent) or in a letter format. It is confidential to the extent permitted pursuant to Government Code Sections 6254(r) and 6254.10 and shall not be included in any document provided to the public.

Countable Tree see 4528(b).

Critical Period means the time of year when the special timber operations practices set forth in these regulations are required to minimize nesting disturbance to a species of special concern.

Crop of Trees (within the meaning of PRC 4526), any number of trees which can be harvested commercially.

Cumulative Impacts means those impacts as defined in 14 CCR 15355.

Current archaeological records check means a review of the State's archaeological and historic resource files conducted at the appropriate Information Center of the California Historical Resource Information System for the area which could be affected by timber operations. The Office of Historic Preservation, which is within the Department of Parks and Recreation, has the address for the regional Information Center a person must contact. The records check must have been conducted within five years prior to the date a THP, NTMP, or Emergency Notice of 3 acres or more is submitted to the Director.

Cutover Land see PRC 4522.5.

Cutting method: means silvicultural method within the Southern Subdistrict of the Coast Forest District.

Damaging effects means demolition, destruction, relocation, or significant alteration of an archaeological or historical site or resource before the significance of the site is determined.

CALIFORNIA FOREST PRACTICE RULES

Danger Tree means any tree located on or adjacent to a utility right-of-way or facility that could damage utility facilities should it fall where: (1) the tree leans toward the right-of-way, or (2) the tree is defective because of any cause, such as: heart or root rot, shallow roots, excavation, bad crotch, dead or with dead top, deformity, cracks or splits, or any other reason that could result in the tree or a main lateral of the tree falling. See Chapter VII, *Hazardous Tree Identification, Powerline Fire Prevention Field Guide-1977*, A Joint Publication of the California Department of Forestry and Fire Protection, U.S. Forest Service, and U.S. Bureau of Land Management.

Department means the Department of Forestry [*and Fire Protection*].

Diameter (when measuring standing live trees), the average diameter of a tree measured outside the bark, at breast height, a point 4.5 feet (1.37m) above the average ground level.

Director means the Director of Forestry [*and Fire Protection*].

Diseased trees means trees which have abnormal physiological conditions or structural changes that result in a substantial adverse effect on the trees' health or threatens to spread the disease, thus threatening the sustained health of surrounding trees. These conditions or structural changes express characteristic signs or symptoms and are caused by identifiable biotic or abiotic agents including, but not limited to, fungi, bacteria, insects, parasitic plants, vertebrates, lightning, fire and mechanical wounds.

District see PRC 4523.

Ditch Drain means a drainage structure or facility which will move water from an inside road ditch to an outside area.

Dominants means trees with well-developed crowns extending above the general level of the forest canopy and receiving full light from above and partly from the sides.

Domestic Water Use means the use of water in homes, resorts, motels, organization camps, developed campgrounds, including the incidental watering of domestic stock for family sustenance or enjoyment and the irrigation of not more than one half acre in lawn, ornamental shrubbery, or gardens at any single establishment. The use of water at a developed campground or resort for human consumption, cooking or sanitary purposes is a domestic use.

Drainage Facilities means facilities constructed to control water, including, but not limited to, fords, inside ditches, waterbreaks, outsloping and rolling dips.

Drainage Structure means a structure installed to control, divert or to cross over water, including, but not limited to, culverts, bridges and ditch drains.

Dunning's Classification Although initially devised exclusively for pine, here is intended to apply to all commercial coniferous species and means a system of tree classification based on maturity of trees, age, position of tree crown in stand, shape of top, diameter, density of foliage and risk or susceptibility of tree to insect and other mortality where trees are classed as follows:

Class 1. Tree immature, 60 to 150 years of age, crown dominant or extending above general level of the crown cover, top pointed, d.b.h. up to 30 in. (76.2 cm), foliage dense and risk good.

Class 2. Tree immature, 60 to 150 years of age, crown codominant or equal to general level of the crown cover, top pointed, d.b.h. up to 24 in. (61.0 cm), foliage dense and risk good.

Class 3. Tree mature, 150 to 300 years of age, crown dominant or extending above general level of the crown cover, top rounded, d.b.h. 18 in. (45.7 cm) to 40 in. (101.6 cm), foliage moderately dense and risk fair to good.

Class 4. Tree mature, 150 to 300 years of age, crown codominant or equal to general level of the crown cover, top rounded and risk poor to fair.

Class 5. Tree overmature, over 300 years of age, crown dominant or extending above the general level of the crown cover, top flat, foliage thin, and risk poor.

Class 6. Tree immature, 60 to 150 years of age, crown intermediate to or suppressed by the general level of the crown cover, top pointed, d.b.h. 12 in. (30.5 cm) to 15 in. (38.1 cm), foliage moderately dense and risk fair to good.

Class 7. Tree mature or overmature, over 150 years of age, crown intermediate or suppressed by the general level of the crown cover, top flat, d.b.h. rarely over 18 in. (45.7 cm), foliage sparse and risk poor (Ref. Sec. 4531, PRC).

Dying Trees means trees which exhibit one or more of the following: fifty percent or more of the foliage-bearing crown is dead or fading in color from a normal green to yellow, sorrel, or brown, excluding normal autumn coloration changes; successful bark beetle attacks with indications of dead

CALIFORNIA FOREST PRACTICE RULES

cambium and brood development distributed around the circumference of the bole; seventy-five percent or more of the circumference of the lower bole is girdled by wildlife; or trees designated by an RPF as likely to die within one year.

Effects means effects and impacts as defined in 14 CCR 15358.

Emergency means those conditions that will cause waste or loss of timber resources to the timber owner that may be minimized by immediate harvesting of infected, infested or damaged timber or salvaging down timber; or those conditions that will cause appreciable financial loss to the timber owner that may be minimized by immediate harvesting of timber.

End-Hauling means the removal and transportation of excavated material to prevent sidecast.

Energy Dissipator means a device or material used to reduce the energy of flowing water.

Equipment Exclusion Zone (EEZ) means the area, as explained in the THP, where heavy equipment associated with timber operations is totally excluded for the protection of water quality, the beneficial uses of water, and/or other forest resources.

Equipment Limitation the term used when the use of timber harvesting equipment is to be limited for the protection of water quality, the beneficial uses of water, and/or other forest resources.

Equipment Limitation Zone (ELZ) means the area, as explained in the THP, where heavy equipment associated with timber operations is limited for the protection of water quality, the beneficial uses of water, and/or other forest resources.

Erosion Controls means drainage facilities, soil stabilization treatments, road and landing abandonment, removal and treatment of watercourse crossings, and any other features or actions to reduce surface erosion, gullying, channel erosion, and mass erosion.

Erosion Hazard Rating (For the Coast and Southern Forest District:) means the rating derived from the procedure specified in 14 CCR 912.5 (952.5) designed to evaluate the susceptibility of the soil within a given location to erosion.

Erosion Potential: (For the Southern Forest District:) See 14 CCR 952.5 (Ref. Sec. 4562 PRC).

Estimated Erosion Potential (For the Northern Forest District:) means the product of the soil and slope values derived from the table in 14 CCR 932.5 or as such product may be modified in accordance "with the instructions contained in that section" (Ref. Sec. 4562, PRC).

Excess Material means material that is not used or needed as a functional part of the road or a landing.

Executive Officer means the Executive Officer of the State Board of Forestry [*and Fire Protection*] authorized by PRC 739.

Extended Dry Periods means those periods during the winter period when saturated soil conditions do not exist.

Feasible means capable of being accomplished in a successful manner within a reasonable period of time, taking into account economic, environmental, legal, social and technical factors. With regard to economic feasibility, the issue shall be whether the plan as revised could be conducted on a commercial basis within 3 years of the submission of the plan and not solely on the basis of whether extra cost is required to carry out the alternatives.

Fifty-Year Flood Flow means that magnitude of peak flow which one would expect to be equaled or exceeded, on the average, once every 50 years. This flow shall be estimated by empirical relationships between precipitation and watershed characteristics and runoff and then may be modified by direct channel cross section measurements and local experience.

Fill means material that is placed in low areas and built up to form the roadbed or landing surface.

Fire Protection Zone (For the Coast and the Southern Forest District:) means that portion of the logging area within 100 feet (30.48 m) as measured along the surface of the ground, from the edge of the traveled surface of all public roads and railroads; and within 200 feet (60.96 m) as measured along the surface of the ground, from permanently located structures currently maintained for human habitation.

Fire Protection Zone (For the Northern Forest District:) means that portion of the logging area within 100 ft. (30.48 m), as measured along the surface of the ground, from the edge of the traveled surface of all public roads and railroads, and 50 ft. (15.24 m) as measured along the surface of the ground from the traveled surface of all private roads, and within 100 ft. (30.48 m), as measured along the surface of the ground, from permanently located structures currently maintained for human habitation (Ref. Sec. 4561.6, PRC).

CALIFORNIA FOREST PRACTICE RULES

Fuelbreak see PRC 4528(e).

Functional Foraging Habitat is dependent upon the presence and availability of prey on the forest floor or in the canopy; presence of accessible perching limbs; and adjacency to stands with canopy closures >40%. Average stem diameter is usually >6" D.B.H. for hardwoods and >11" D.B.H. for conifers among dominants, and codominants, and the total overhead canopy closure, including intermediate trees is at least 40%. Where overall canopy closure is >80%, foraging habitat is limited to areas with ample flight space below limbs and among stems. Foraging habitat in smaller size classes and lower percentage canopy closures must be justified by local information.

Functional Nesting Habitat means habitat with a dominant and codominant tree canopy closure of at least 40% and a total canopy (including dominant, codominant, and intermediates) of at least 60%. Usually the stand is distinctly multi-layered with an average stem diameter in dominant, and codominant conifers, and hardwoods >11" D.B.H. The stand usually consists of several tree species (including hardwoods) of mixed sizes. All nests, snags, down logs, and decadent trees shall also be considered as part of the habitat. Nesting substrates are provided by broken tops, cavities, or platforms such as those created by a hawk or squirrel nest, mistletoe broom, or accumulated debris. Owls are known to occasionally nest in less than optimal habitat. Nesting areas may also be associated with characteristics of topographic relief and aspect which alter microclimates.

Functional Roosting Habitat during the territorial breeding season, consists of stands where average stem diameter is >11" D.B.H. among dominant and codominant trees. Hardwood and conifers provide an average of at least 40% canopy closure but the stand can have a high degree of variability. Stand size and configuration must be sufficient to provide multiple perch sites which are suitable for protection from various environmental conditions, including wind, heat, and precipitation.

Functional Wildlife Habitat means vegetative structure and composition which function to provide essential characteristics for wildlife feeding, reproduction, cover and movement between habitats. The habitat components must be in sufficient quantities and arrangement to support the diverse assemblage of wildlife species that are normally found on or use forestlands within that area. Within this definition the following terms mean:

Function(al): Refers to ecological relationships between both the habitat components and needs of the species which allows for all of the normal life cycle including, migration corridors, genetic pathways, food availability, temperature protection, moisture retention, nutrient cycling, denning, spawning, nesting, and other functions necessary to complete a life cycle.

Composition: Refers to the types, abundance, distribution, and ecological relationships of species of terrestrial and aquatic vegetation within the forest stand including dominance, richness, trophic levels and other population and community features at levels which affect the long-term survival of individual forest species.

Structure: Refers to the physical arrangement of and relationships between living and non-living terrestrial and aquatic components within the forest stand including, age, size, height and spacing of live vegetation in the forest in addition to seeps, spawning gravels, pools, springs, snags, logs, den trees, meadows, canopy coverage, levels of canopies and other physical features necessary to allow species to function.

Good Cause is Shown (as used in PRC 4590), the plan submitter presents facts which describe the factors beyond the control of the plan submitter and his or her agents, such as: market conditions, weather, technical difficulties or natural disaster, that have prevented feasible completion of the timber operation within the effective period of the plan.

Harm means an act where it actually kills or injures a federally listed wildlife species. Such acts may include a significant habitat modification or degradation which actually kills or injures wildlife by significantly impairing essential behavioral patterns, including breeding, feeding or sheltering.

Harass means an intentional or negligent act or omission which creates the likelihood of injury to a federally listed wildlife species by annoying it to such an extent as to significantly disrupt normal behavioral patterns which include, but are not limited to, breeding, feeding or sheltering.

Hard Frozen Conditions means those frozen soil conditions where loaded or unloaded vehicles can travel without sinking into the road surfaces to a depth of more than six inches over a distance of more than 25 feet.

CALIFORNIA FOREST PRACTICE RULES

Harvesting Method means the process used to cut and remove timber. It may have as its silvicultural objective either stand regeneration or intermediate treatments.

Inner Gorge means a geomorphic feature formed by coalescing scars originating from landsliding and erosional processes caused by active stream erosion. The feature is identified as that area beginning immediately adjacent to the stream channel below the first break in slope.

Intermediate Treatments means harvests conducted to modify or guide the development of an existing stand of trees, but not to replace (regenerate) the stand with a new one. The treatments involve the removal of trees to allow expansion of the crowns and root systems.

Intermediates means trees with crowns below the general level of the forest canopy and receiving little light from either above or the sides. Intermediates have minimally-developed crowns and are crowded on the sides.

Lake is a permanent natural body of water of any size, or an artificially impounded body of water having a surface area of at least one acre, isolated from the sea, and having an area of open water of sufficient depth and permanency to prevent complete coverage by rooted aquatic plants.

Landing means that area where forest products are concentrated prior to loading for transportation to market.

Late Succession Forest Stands means stands of dominant and predominant trees that meet the criteria of WHR class 5M, 5D, or 6 with an open, moderate or dense canopy closure classification, often with multiple canopy layers, and are at least 20 acres in size. Functional characteristics of late succession forests include large decadent trees, snags, and large down logs.

Layout means a prepared a prepared bed into which a tree is felled. A layout is generally constructed by tractor and is intended to reduce the breakage that occurs during the felling of trees.

License see PRC 4524.

Listed Species means a plant or animal species which is listed as rare, threatened or endangered under federal or state law, or a sensitive species by the Board.

Live and Healthy as used in PRC 4528(b)(2) a tree that is a potential crop tree.

Log Culvert means a drainage structure consisting of logs or logs and fill material placed in a drainage in such a manner as to allow for the passage of water. Also commonly referred to as a "Humboldt crossing".

Logging Area means that area on which timber operations are being conducted as shown on the map accompanying the Timber Harvesting Plan, and within 100 feet, as measured on the surface of the ground, from the edge of the traveled surface of appurtenant roads owned or controlled by the timberland owner, timber operator or timber owner, and being used during the harvesting of the particular area. The traveled surface of such appurtenant roads is also part of the logging area.

Logging Road means a road other than a public road used by trucks going to and from landings to transport logs and other forest products.

Long Term Significant Adverse Effect on fish, wildlife, or listed species known to be primarily associated with late succession forest stands means an effect that creates an identifiable trend or set of conditions which provide a substantial level of scientific evidence that a population of one or more species of fish, wildlife, or listed species primarily associated with late succession forest stands will become extirpated from a significant portion of its current range in the Forest District within the planning horizon.

Long Term Sustained Yield means the average annual growth sustainable by the inventory predicted at the end of a 100 year planning period.

Lopping: (For the Coast and Northern Forest Districts:) Severing and spreading of slash so that no part of it remains more than 30 in. (76.2 cm) above the ground (Ref. Sec. 4551.5, PRC).

Lopping: (For the Southern Forest District:) Severing limbs from the exposed sides of the unutilized portions of trees so that portions of the severed limbs are in contact with the ground (Ref. Sec. 4551.5, PRC).

Lopping for Fire Hazard Reduction means severing and spreading slash so that no part of it generally remains more than 30 inches above the ground except where a specific rule provides another standard.

Manmade Watercourse means a watercourse which is constructed and maintained to facilitate man's use of water and includes, but is not limited to, ditches and canals used for domestic, hydropower, irrigation, and other beneficial uses (man made watercourses as defined do not include roadside drainage ditches).

CALIFORNIA FOREST PRACTICE RULES

Marking means a painted horizontal band or other distinguishing designation which is visible from two sides of a tree, and a stump designation, if required in the THP, which is visible after felling operations.

Meadows and wet areas (For the Northern Forest District:) means those areas which are moist on the surface throughout most of the year and/or support aquatic vegetation, grasses and forbs as their principal vegetative cover (Ref. Sec. 4562.7, PRC).

Meadows and Wet Areas: (For the Southern Forest District:) Those areas which are moist on the surface throughout most of the year and/or support aquatic vegetation, grasses and forbs as their principal vegetative cover.

Mechanical Site Preparation means all site preparation activities undertaken by motorized heavy equipment to prepare an area for regeneration.

Minor Deviations means any change, minor in scope, in a plan which can reasonably be presumed not to make a significant change in the conduct of timber operations and which can reasonably be expected not to significantly adversely affect timberland productivity or values relating to soil, water quality, watershed, wildlife, fisheries, range and forage, recreation, and aesthetic enjoyment.

Native Americans means local federally recognized tribal governments, and those California Native American organizations and individuals, as listed on the Native American contact list provided to the Director by the Native American Heritage Commission (NAHC) for the area that contains the proposed timber operation. The Director shall ensure that the list provided by the Department for archaeological and historical work includes all "Native Americans" identified by January 1st of each year.

Nest Site means the geographic area surrounding habitat that includes the nest tree(s), perch tree(s), screening tree(s), and replacement tree(s) of a bird species of special concern.

Nest Tree means the tree, snag, or other structure that contains the nest of a species of special concern.

Occupied Nest means a nest currently being used by one or more adult birds with eggs or young present.

Overhanging Bank means a condition in which the upper portion of a cut slope projects (hangs) over the lower portion of a cut slope.

Overstory means that portion of the trees, in a forest of more than one story, forming the upper canopy layers.

Owl Habitat means Type A, B, or C owl habitat or those areas with functional foraging habitat, functional nesting habitat, and functional roosting habitat which support the owl's biological needs for breeding, sheltering, and feeding. An area of habitat could have characteristics which support all of the functional needs for nesting, roosting, and foraging or a combination of those functions. Because owls are known to occasionally inhabit less than optimal forest structure, local information can be used to justify the modification of functional habitat definitions.

Past Projects means previously approved, on-going, or completed projects which may add to or lessen impact(s) created by the THP under consideration. These generally include, but may not be limited to, projects completed within the last ten years.

Perch Tree means a tree or snag identified and designated by the RPF or supervised designee in consultation with the Department of Fish and Game as utilized periodically by a species of special concern for nesting, territorial defense, or as an approach to its nest or feeding area.

Permanent Road means a road which is planned and constructed to be part of a permanent all-season transportation facility. These roads have a surface which is suitable for the hauling of forest products throughout the entire winter period and have drainage structures, if any, at watercourse crossings which will accommodate the fifty-year flood flow. Normally they are maintained during the winter period.

Permanent Watercourse Crossing means a watercourse crossing that will be constructed to accommodate the estimated fifty-year flood flow and will remain in place when timber operations have been completed.

Person see PRC 4525.

Plan means:

- (a) Timber Harvesting Plan (THP) as described in PRC 4582.
- (b) Nonindustrial Timber Management Plan (NTMP) as described in PRC 4593.2(e).
- (c) Program Timber Harvesting Plan (PTHP) as described in 14 CCR 1092 and 1092.1.

CALIFORNIA FOREST PRACTICE RULES

Planning Watershed means the contiguous land base and associated watershed system that forms a fourth order or other watershed typically 10,000 acres or less in size. Planning watersheds are used in planning forest management and assessing impacts. The Director has prepared and distributed maps identifying planning watersheds plan submitters must use. Where a watershed exceeds 10,000 acres, the Director may approve subdividing it. Plan submitters may propose and use different planning watersheds, with the Director's approval. Examples include but are not limited to the following: when 10,000 acres or less is not a logical planning unit, such as on the Eastside Sierra Pine type, as long as the size in excess of 10,000 acres is the smallest that is practical. Third order basins flowing directly into the ocean shall also be considered an appropriate planning watershed.

Predominant Trees are those whose crowns are above the general level of the canopy and are significantly older than the surrounding stand.

Prescribed Maintenance Period means the period, beginning with filing of the work completion report provided the report is approved during which erosion controls which are required and constructed as part of a timber operation must be maintained in a functional condition. The period shall not exceed three years from the filing of the work completion report provided that the report is subsequently approved by the director.

Professional Archaeologist means a person who holds at least a Bachelor of Arts or Science degree in Anthropology or Archaeology from a college or university and has completed at least three years of professional experience in research, writing, or project supervision in archaeological investigation or cultural resource management and protection programs.

Program Timberland Environmental Impact Report (PTEIR), means a Program Environmental Impact Report in compliance with CEQA for ongoing management of timberlands, including timber operations and related land management practices which require permits from public agencies. Subsequent PTHPs shall be tied to a PTEIR.

Program Timber Harvesting Plan (PTHP), means a Timber Harvesting Plan prepared by an RPF which relies upon a PTEIR for CEQA compliance and meets the standards of PRC Section 4581. PTHPs must be within the scope of the PTEIR, the rules of the board and other applicable state laws.

Project means an activity which has the potential to cause a physical change in the environment, directly or ultimately, and that is: 1) undertaken by a public agency, or 2) undertaken with public agency support, or 3) requires the applicant to obtain a lease, permit, license or entitlement from one or more public agencies. This includes Timber Harvesting Plans.

Public fire agency means California Department of Forestry and Fire Protection, United States Forest Service, Bureau of Land Management, and other federal fire protection agencies, counties providing fire protection pursuant to PRC 4129, or city, county, or local fire agencies.

Public Road means a road open to the general public which is: (a) in the State or County road system, or (b) a road on which a public agency has deeded, unlimited easement.

Quality of Water means the level of water quality as specified by the applicable Water Quality Control Plan, including its water quality objectives, policies and prohibitions.

Range of the Northern Spotted Owl means the following counties: Marin, Napa, Del Norte, Mendocino, Colusa, Shasta (north of HWY 299, west of I-5), Tehama (west of I-5), Sonoma, Humboldt, Lake, Trinity, Siskiyou, Glenn (west of I-5), Modoc (west of HWY 139).

Reasonably Foreseeable Probable Future Projects means projects with activities that may add to or lessen impact(s) of the proposed THP including but not limited to: 1) if the project is a THP on land which is controlled by the THP submitter, the THP is currently expected to commence within but not limited to, 5 years or, 2) if the project is a THP on land which is not under the control of the THP submitter the THP has been submitted or on-the-ground work including THP preparation has materially commenced, or 3) if the project is not a THP, and a permit is required from a public agency, and the project is under environmental review by the public agency, or 4) if the project is one which is under taken by a public agency, the agency has made a public announcement of the intent to carry out the project.

Reconstructed Roads means those existing roads that are to be restored or improved to make them useable for hauling forest products; "reconstructed" does not include routine or annual maintenance or rehabilitation that does not require substantial change in the original prism of the road.

Reconstruction of Existing Tractor Roads means restoring or improving the surface of pre-existing tractor roads or skid trails in a manner that requires substantial cutting or filling of soil or rock.

CALIFORNIA FOREST PRACTICE RULES

Regeneration Method means the process used to secure replacement of a forest stand.

Registered Professional Forester means a person who holds a valid license as a professional forester pursuant to Article 3, Chapter 2, Division 1 of the Public Resources Code.

Replacement Tree means a tree or snag within the nest site of a species of special concern identified and designated by the RPF or supervised designee in consultation with the Department of Fish and Game as being suitable as a replacement for a nest or perch tree should the existing tree become unusable.

Reproduction (For the Southern Forest District:) means young trees of commercial species that are less than 4 in. (10.2 cm) d.b.h., i.e., seedlings and saplings.

Resource Conservation Standards see PRC 4525.3.

Rigging means the cable (wire rope), blocks, and hood equipment used in cable yarding systems.

Riparian means the banks and other adjacent terrestrial environs of lakes, watercourses, estuaries, and wet areas, where transported surface and subsurface freshwaters provide soil moisture to support mesic vegetation.

Rip-Rap means rock or other suitable material placed to prevent or reduce erosion.

Road Failure means damage to the roadbed not permitting vehicular passage for hauling of forest products, but does not mean cut bank or fill sloughing incidental to road settling.

Rolling Dip means a drainage facility that is constructed to remain effective while allowing passage of motor vehicles at reduced road speeds.

Sampling Area means the area delineated on a map accompanying a report of stocking showing the area sampled by one of the procedures specified in 14 CCR 1072.

Saturated Soil Conditions means that site conditions are sufficiently wet that timber operations displace soils in yarding or mechanical site preparation areas or displace road and landing surface materials in amounts sufficient to cause a turbidity increase in drainage facilities that discharge into Class I, II, III, or IV waters, or in downstream Class I, II, III, or IV waters that is visible or would violate applicable water quality requirements.

In yarding and site preparation areas, this condition may be evidenced by: a) reduced traction by equipment as indicated by spinning or churning of wheels or tracks in excess of normal performance, b) inadequate traction without blading wet soil, c) soil displacement in amounts that cause visible increase in turbidity of the downstream waters in a receiving Class I, II, III, or IV waters, or in amounts sufficient to cause a turbidity increase in drainage facilities that discharge into Class I, II, III, or IV waters, or d) creation of ruts greater than would be normal following a light rainfall.

On logging roads and landing surfaces, this condition may be evidenced by a) reduced traction by equipment as indicated by spinning or churning of wheels or tracks in excess of normal performance, b) inadequate traction without blading wet soil, c) soil displacement in amounts that cause visible increase in turbidity of the downstream waters in receiving Class I, II, III, or IV waters, or in amounts sufficient to cause a turbidity increase in drainage facilities that discharge into Class I, II, III, or IV waters, d) pumping of road surface materials by traffic, or e) creation of ruts greater than would be created by traffic following normal road watering, which transports surface material to a drainage facility that discharges directly into a watercourse.

Soils or road and landing surfaces that are hard frozen are excluded from this definition.

Scattered parcel means a timberland ownership within a planning watershed is less than 10% of the area of the watershed and does not adjoin a planning watershed where the timberland ownership is greater than 20% of the watershed.

Screening Trees means those trees or snags identified and designated by the RPF or supervised designee in consultation with the Department of Fish and Game as necessary to protect nest trees of species of special concern from the impacts of human activities and natural elements.

Seasonal Road means a road which is planned and constructed as part of a permanent transportation facility where: 1) commercial hauling may be discontinued during the winter period, or 2) the landowner desires continuation of access for fire control, forest management activities, Christmas tree growing, or for occasional or incidental use for harvesting of minor forest products, or similar activities. These roads have a surface adequate for hauling of forest products in the non-winter periods, and in the extended dry periods or hard frozen conditions occurring during the winter period; and have drainage structures, if any, at watercourse crossing which will accommodate the fifty-year flood flow. Some maintenance usually is required.

CALIFORNIA FOREST PRACTICE RULES

Seed Tree a thrifty vigorous tree of commercial species of seed bearing age, with full crown, and free from damage caused by timber operations and hazard abatement which would impair seed productivity.

Sensitive Species means those species designated by the Board pursuant to 14 CCR 898.2(d). These species are the Bald eagle, Golden eagle, Great blue heron, Great egret, Northern goshawk, Osprey, Peregrine falcon, California Condor, Great gray owl, Northern spotted owl, and Marbled Murrelet.

Sidecast means excess earthen material pushed or dumped to or over the side roads or landings.

Significant Adverse Impact on the Environment means a substantial, or potentially substantial, adverse change in any of the physical conditions within the area affected by the project including land, air, water, minerals, flora, fauna, ambient noise, and objects of historic or aesthetic significance. An economic or social change by itself shall not be considered a significant effect on the environment. A social or economic change related to a physical change may be considered in determining whether the physical change is significant.

Significant archaeological or historical site means a specific location which may contain artifacts, or objects and where evidence clearly demonstrates a high probability that the site meets one or more of the following criteria:

(a) Contains information needed to answer important scientific research questions.

(b) Has a special and particular quality such as the oldest of its type or best available example of its type.

(c) Is directly associated with a scientifically recognized important prehistoric or historic event or person.

(d) Involves important research questions that historical research has shown can be answered only with archaeological methods.

(e) Has significant cultural or religious importance to California Indians as identified by the Native American Heritage Commission (NAHC) or Native American organizations or individuals in concurrence with the NAHC, or local federally recognized tribal governments.

Silviculture is the theory and practice of controlling the establishment, composition and growth of forests.

Silvicultural Methods in PRC Section 4582(d) is referred to as "silvicultural systems" for purposes of these regulations.

Silvicultural System is the planned program of forest stand treatments during the life of a stand. It consists of a number of integrated steps conducted in logical sequence leading to or maintaining a forest stand of distinctive form for the level of management intensity desired.

Site Classification see PRC 4528(d).

Site Preparation means any activity involving mechanical disturbance of soils or burning of vegetation which is performed during or after completion of timber harvesting and is associated with preparation of any portion of a logging area for artificial or natural regeneration.

Site Preparation Addendum means an addendum to a THP which describes proposed site preparation areas, site preparation practices, and related measures.

Site Preparation Area means any portion of a logging area in which site preparation is conducted.

Site survey area means: the area where a field survey is conducted for archaeological and historical sites which includes the entire logging area except appurtenant roads and those portions of the 100 foot strip along such roads unless there are timber operations to remove commercial wood products that could affect an archaeological or historical site.

Skidding (see "yarding" in this section).

Slash see PRC 4525.7.

Slide Areas are areas indicated by the following characteristics:

1. Shallow-seated Landslide. An area where surface material (unconsolidated rock colluvium, and soil) has moved downslope along a relatively steep, shallow failure surface. The failure surface is generally greater than 65% in steepness and less than 5 feet in depth. It is usually characterized by: 1) a scarp at the top; 2) a concave scar below the scarp, where surface material has been removed; and sometimes 3) a convex area at the bottom where slide material is deposited. Vegetation is usually disturbed (tilted trees), anomalous (younger, evenaged stand), or absent (bare soil). Minor bank slumps are excluded from this definition.

2. Deep-seated Landslide. An area where landslide material has moved downslope either as relatively cohesive mass (rotational slides and translational block slides) or as an irregular, hummocky mass

CALIFORNIA FOREST PRACTICE RULES

(earthflow). The failure surface is generally deeper than five feet and is usually well-exposed at the head scarp. Complex failures with rotational movement at the head and translational movement or earthflows downslope are common. Vegetation on rotational and transitional slides is relatively undisturbed, although trees and shrubs may be pistol-butted or tilted. Deep-seated landslides may have intermediate tension cracks, scarps, and shallow slides superimposed throughout the slide mass. Deep-seated landslide risk is usually associated with cohesive soils.

Small Group means groups of trees in areas up to 2½ acres.

Snag means a standing dead tree or a standing section thereof, regardless of species.

Southern Subdistrict of the Coast Forest District means the timberlands in the Counties of Santa Cruz, Santa Clara, San Mateo, San Francisco and Marin situated within the boundaries of the Coast Forest District.

Special Treatment Areas are specific locations which contain one or more of the following significant resource features which may be at risk during timber operations:

- a. Within 200 feet of the watercourse transition line of federal or state designated wild and scenic rivers;
- b. Within 200 feet of national, state, regional, county or municipal park boundaries;
- c. Key habitat areas of federal or state designated threatened, rare or endangered species;
- d. Coastal Commission special treatment areas;
- e. Within 200 feet of state designated scenic highways or within scenic corridors established pursuant to Article 2.5 (commencing with Section 260) of Chapter 2 of Division 1 and Section 154 of Chap. 1 of Div. 1 of the Streets and Highways Code.

Species means a native species or subspecies of animal or plant in California.

Specific Forest means the area delineated under a Timber Management Plan.

Spotted Owl Resource Plan means a plan that demonstrates an approach to preventing a taking of the northern spotted owl while conducting timber harvest operations. A Spotted Owl Resource Plan necessarily involves more than one timber harvest plan area.

Stable operating surface means that throughout the period of use, the operating surface of a logging road or landing does not either (1) generate waterborne sediment in amounts sufficient to cause a turbidity increase in downstream Class I, II, III, or IV waters, or in amounts sufficient to cause a turbidity increase in drainage facilities that discharge into Class I, II, III, or IV waters or, that is visible or would violate applicable water quality requirements; or (2) channel water for more than 50 feet that is discharged into Class I, II, III, or IV waters.

Stand Vigor is a measure of stand health. A measure of good stand vigor is an exhibition of characteristics which include large live crowns or leaf surface area, high needle retention, pointed tops, crown dominance relative to other trees in the same age or size class, and disease-free.

Stocking see PRC 4528(c).

Stocking Standards means the resource conservation standards established in 14 CCR 912.7 (932.7, 952.7) defining minimum acceptable stocking of an area with commercial tree species (Ref. 14 CCR 912 [932, 952]) after harvesting timber therefrom (Ref. Sec. 4561, PRC).

Stream see PRC 4528(f).

Substantial adverse change means demolition, destruction, relocation, or alteration such that the significance of an archaeological or historical site would be impaired.

Substantial Deviation means changes that are not “minor deviations” as defined in 895.1 and are presumed to be substantial deviations because they could significantly affect the conduct of timber operations and potentially could have a significant adverse affect on timber productivity or values relating to soil, water quality, watershed, wildlife, fisheries, range and forage, recreation and aesthetic enjoyment. Such actions include, but are not limited to:

- (1) Change in location of timber harvesting operations or enlargement of the area to be cut.
- (2) Change in the silvicultural method and cutting system on any portion of the plan area.
- (3) Change in type or location of logging (yarding) system or basic type of equipment.
- (4) Change in location, nature or increase in length of proposed logging roads incorporating one or more of the following criteria:

(A) Any road in the Watercourse and Lake Protection Zone or where sidecast will extend into the Watercourse and Lake Protection Zone.

CALIFORNIA FOREST PRACTICE RULES

(B) Any road located in an extreme Erosion Hazard Rating area in the Coast Forest District, extreme Estimated Erosion Potential area in the Northern Forest District, or a high Erosion Potential area in the Southern Forest District.

(C) Any road where the average side slope exceeds 50%.

(D) Any road where unstable areas, active soil movement, or slide areas must be traversed.

(E) Any increase in gradient allowed by the District Rules as an exception and not provided for in the original plan.

(F) Any road extension of more than 600 feet (182.9 m).

(5) Any use of existing roads not shown in the original plan when reconstruction work to allow for vehicle travel will be substantial. Substantial work on an existing road means more than minor repair and dressing of the travel surface and removal of vegetation to allow for vehicle passage.

(6) Use of any roads not shown in the plan which would affect the key habitat of rare or endangered species or other critical wildlife habitat.

(7) Enlargement of landings where such enlargement was not justified in the original plan.

(8) Any change of operation in, or designation of, the Watercourse and Lake Protection Zone.

(9) Any downgrading of stream classification.

(10) A change to winter operation where summer operations was previously specified.

Substantially damaged timberlands means areas of timberland where wildfire, insects, disease, wind, flood, or other blight caused by an act of God occurs after January 1, 1976 and the damage reduced stocking below the requirements of PRC 4561 or other higher minimum stocking requirements that may be applicable under Articles 3 and 11 of Subchapter 4, Article 3 of Subchapter 5, and Articles 3 and 11 of Subchapter 6.

Supervised Designee means a person, who need not be an RPF, acting as an assistant under the supervision of an RPF pursuant to Article 3, Chapter 2, Division 1 of the Public Resources Code. For the purposes of this definition, "supervision" means the RPF must perform regular and timely quality control, work review and inspection, both in the office and in the field, and be able to take, or effectively recommend, corrective actions where necessary; the frequency of review, inspection and guidance shall take into consideration the experience of the non-RPF and technical complexity of the job, but shall be sufficiently frequent to ensure the accomplishment of work to professional standards.

Suppressed trees are those which have their crowns in the lower layers of the canopy. They receive virtually no direct sunlight, and they are generally growing very slowly.

Surface Cover means the cover of litter, downed woody material (including slash, living vegetation in contact with the ground, and loose rocks (excluding rock outcrops) that resist erosion by raindrop impact and surface flow.

Sustained Yield means the yield of commercial wood that an area of commercial timberland can produce continuously at a given intensity of management consistent with required environmental protection and which is professionally planned to achieve over time a balance between growth and removal.

Take means to harass, harm, pursue, hunt, shoot, wound, kill, trap, capture, collect or to attempt to engage in any such conduct with regard to a federally listed wildlife species.

Temporary Road means a road that is to be used only during the timber operation. These roads have a surface adequate for seasonal logging use and have drainage structures, if any, adequate to carry the anticipated flow of water during the period of use.

THP means Timber Harvesting Plan as described in PRC 4582.

Tight-Lining means to move rigging from one tailblock location to another and tightening the main line to pull the cable to the new position.

Timberland see PRC 4526.

Timber Falling Limitation the term used when special falling techniques and falling practices are required for the protection of water quality and beneficial uses, and/or other forest resources.

Timber Operations see PRC 4527.

Timber Operator see PRC 4526.5.

Timber Owner see PRC 4527.5.

To Plan means examination of feasible alternatives, field review of alternatives, and reflection of this examination and field review in choice of road or landing locations, and other factors, together with associated mitigation measures in the harvest plan.

Tractor Operations means any activity which is associated with timber operations and is performed by

CALIFORNIA FOREST PRACTICE RULES

tractors or skidders.

Tractor Roads means constructed trails or established paths used by tractors or other vehicles for skidding logs. Also known as "skid trails".

Tractor Yarding means that system of skidding (transporting) logs by a self-propelled vehicle, generally by dragging the logs with a grapple or chokers.

Type A Owl Habitat means timber stands that have as a minimum the following characteristics for live-tree structure:

1. Canopy layers: The stand has two distinct tiers or is multi-layered with dominant conifers greater than 120 ft. tall (trees greater than 90 ft. tall on poor sites, less than site III, and for some montane tree species). Conifers or hardwoods dominate the canopy layers less than 120 ft. tall.

2. Canopy Closure: The canopy closure of conifers greater than 120 ft. tall (or greater than 90 ft. tall on poor sites, less than site III, and for some montane tree species) averages greater than 40% and not less than 20%. The total canopy closure for all trees, conifers or hardwoods, is greater than 60%.

3. Large Trees: The density of conifers greater than 35 in. d.b.h. averages more than nine stems per acre and not less than six stems per acre and includes a component of trees with sparse, broken, or dead tops.

4. Medium Trees: The density of conifers or hardwoods 18 to 35 in. d.b.h. averages more than 15 stems per acre and not less than 8 stems per acre.

5. Small Trees: The density of conifers or hardwoods less than 18 in. d.b.h. averages more than 50 stems per acre and not less than 20 stems per acre.

Type B Owl Habitat means timber stands that have as a minimum the following characteristics for live-tree structure:

1. Canopy Layers: Moderately to strongly two-tiered or multi-layered with dominant conifers greater than 100 ft. tall (greater than 70 ft. tall on poor sites, less than site III, and for some montane tree species). Conifers or hardwoods dominate the canopy layers less than 100 ft. tall.

2. Canopy Closure: The canopy closure of conifers greater than 100 ft. tall (or greater than 70 ft. tall on poor sites, less than site III, and for some montane tree species) averages greater than 40% and not less than 20%. The total closure for all trees, conifers or hardwoods, is greater than 60%.

3. Large Trees: The density of conifers greater than 35 in. d.b.h. averages more than six stems per acre and not less than two stems per acre.

4. Medium Trees: The density of conifers or hardwoods 18 to 35 in. d.b.h. averages more than 25 stems per acre and not less than 20 stems per acre.

5. Small Trees: The density of conifers or hardwoods less than 18 in. d.b.h. averages more than 50 stems per acre and not less than 20 stems per acre.

Type C Owl Habitat means timber stands that have as a minimum the following characteristics for live-tree structure:

1. Canopy Layers: Uniform to moderately layered with dominant conifers or hardwoods 50 to 100 ft. tall although low numbers of emergent trees greater than 100 ft. tall may be present.

2. Canopy Closure: The canopy closure of conifers or hardwoods 50 to 100 ft. tall averages greater than 40% and not less than 20%. The total canopy closure for all trees, conifers or hardwoods, is greater than 60%.

3. Large Trees: The density of conifers greater than 35 inches d.b.h. averages less than six stems per acre and may be absent.

4. Medium Trees: The density of conifers or hardwoods 18 to 35 in. d.b.h. averages more than 15 stems per acre, but may be absent.

5. Small Trees: The density of conifers or hardwoods less than 18 inches d.b.h. averages more than 160 stems per acre and not less than 50 stems per acre. The average d.b.h. for all trees in the stand, including small, medium, and large trees is greater than 10 inches.

Understory means, generally, trees and woody species growing under an overstory.

Unevenaged Management means management of a specific forest, with the goal of establishing a well stocked stand of various age classes and permits the periodic harvest of individual or small groups of trees to realize the yield and continually establish a new crop.

Unique Area means special treatment areas defined in the 14 CCR 895.1, 912, 932, and 952.

CALIFORNIA FOREST PRACTICE RULES

Unstable Areas are characterized by slide areas or unstable soils or by some or all of the following: hummocky topography consisting of rolling bumpy ground, frequent benches, and depressions; short irregular surface drainages begin and end on the slope; tension cracks and head wall scarps indicating slumping are visible; slopes are irregular and may be slightly concave in upper half and convex in lower half as a result of previous slope failure; there may be evidence of impaired ground water movement resulting in local zones of saturation within the soil mass which is indicated at the surface by sag ponds with standing water, springs, or patches of wet ground. Some or all of the following may be present: hydrophytic (wet site) vegetation prevalent; leaning, jackstrawed or split trees are common; pistol-butted trees with excessive sweep may occur in areas of hummocky topography (note: leaning and pistol butted trees should be used as indicators of slope failure only in the presence of other indicators).

Unstable Soils may be indicated by the following characteristics:

1. Unconsolidated, non-cohesive soils (coarser textured than Loam, as defined in Appendix I.A.1a of Board of Forestry Technical Rule Addendum No. 1, dated December 15, 1981) and colluvial debris including sands and gravels, rock fragments, or weathered granitics. Such soils are usually associated with a risk of shallow-seated landslides on slopes of 65% or more, having non-cohesive soils less than 5 ft. deep in an area where precipitation exceeds 4 in. in 24 hours in a 5-year recurrence interval.

2. Soils that increase and decrease in volume as moisture content changes. During dry weather, these materials become hard and rock-like exhibiting a network of polygonal shrinkage cracks and a blocky structure resulting from desiccation. Some cracks may be greater than 5 feet in depth. These materials when wet are very sticky, dingy, shiny, and easily molded.

Various Age Classes means a stand with at least three distinct layers of tree crowns (size classes).

Vegetation Protection the term used when special measures are required to prevent damage to vegetation for the protection of water quality, the beneficial uses of water, and/or other forest resources.

Waterbreak means a ditch, dike, or dip, or a combination thereof, constructed diagonally across logging roads, tractor roads and firebreaks so that water flow is effectively diverted therefrom. Waterbreaks are synonymous with waterbars.

Watercourse means any well-defined channel with distinguishable bed and bank showing evidence of having contained flowing water indicated by deposit of rock, sand, gravel, or soil, including but not limited to, streams as defined in PRC 4528(f). Watercourse also includes manmade watercourses.

Watercourse and Lake Protection Zone (WLPZ) means a strip of land, along both sides of a watercourse or around the circumference of a lake or spring, where additional practices may be required for protection of the quality and beneficial uses of water, fish and riparian wildlife habitat, other forest resources and for controlling erosion.

Watercourse Bank means the portion of the channel cross-section that confines the normal high water flow.

Watercourse or Lake Transition Line

(a) for a watercourse with an unconfined channel (a channel with a valley to width ratio at bankfull stage of 4 or greater) means that line defined by the landward margin of the most active portion of the channel zone area readily identified in the field by riverine hardwood and conifer trees at least twenty-five (25) years in age at breast height.

(b) for a watercourse with a confined channel (b) means that line that is the outer boundary of a watercourse's 20-year return interval flood event floodplain. This outer boundary corresponds to an elevation equivalent to twice the maximum depth of the adjacent riffle at bankfull stage. The bankfull stage elevation shall be determined by field indicators and may be verified by drainage area/bankfull discharge relationships.

(c) for a lake, it is that line closest to the lake where riparian vegetation is permanently established.

Watersheds with threatened or impaired values means any planning watershed where populations of anadromous salmonids that are listed as threatened, endangered, or candidate under the State or Federal Endangered Species Acts with their implementing regulations, are currently present or can be restored.

Wet meadows and other wet areas means those natural areas except cutover timberland which are moist on the surface throughout most of the year and support aquatic vegetation, grasses and forbs as their principal vegetative cover.

While Giving Consideration means the selection of those feasible silvicultural systems, operating methods and procedures which substantially lessen significant adverse impact on the environment and which

CALIFORNIA FOREST PRACTICE RULES

best achieve long-term, maximum sustained production of forest products, while protecting soil, air, fish and wildlife, and water resources from unreasonable degradation, and which evaluate and make allowance for values relating to range and forage resources, recreation and aesthetics, and regional economic vitality and employment.

Winter Period means the period between November 15 to April 1, except as noted under special County Rules at 14 CCR, Article 13 § 925.1, 926.18, 927.1, and 965.5.

Woody debris means woody material four inches and greater in diameter and no less than two feet long left on the ground as the result of timber operations.

Yarding means the movement of forest products from the point of felling to a landing.

CONFIDENTIAL ARCHAEOLOGICAL ADDENDUM FOR TIMBER OPERATIONS ON NON-FEDERAL LANDS IN CALIFORNIA

This report form may only be used to document an archaeological and historical resource survey and impact assessment for a Timber Harvesting Plan (THP), Non-industrial Timberland Management Plan (NTMP), Program Timber Harvesting Plan (PTHP), Emergency Notice (EM), Modified Timber Harvesting Plan (MTHP), or other commercial timber operation on privately-owned or other non-federal lands within California pursuant to California's Forest Practice Regulations (14 CCR Section 929, 949, 969 et seq.). This entire report, except Parts I and V, is confidential and may not be included in any document provided to the public. Completed reports will be reviewed by a CDF Archaeologist as part of the overall project review conducted by CDF. Any questions pertaining to the use of this report form, the Forest Practice Regulations which address protection of archaeological resources, or archaeological investigations of commercial timber operations may be directed to CDF Archaeology Program Manager Dan Foster at (916) 653-0839 or to any of the regional CDF Archaeologists.

Part I: ADMINISTRATIVE INFORMATION

Note: The information in Part I is not confidential and may be released to the public.

Name of Surveyor:	Name of RPF :
Address:	Address:
Phone #:	Phone #:
Project Name:	Project #:
Project Type:	Approximate Acreage:
County:	Legal Description:
Name of USGS 7.5' Quad(s):	Date Report Completed:
Author of Report:	Signature of Archaeological Surveyor:

Part II: ARCHAEOLOGICAL RECORDS CHECK INFORMATION

A current archaeological records check conducted at the appropriate Information Center of the California Historical Resource Information System must have been conducted for this project area. A copy of the completed records check request form, map, and reply (including mapped information) from the Information Center must be included as an attachment to this report, or a justification provided as to why that is not possible. If a copy of written records check information cannot be attached, provide a justification, the date of the records check, the Information Center File Number, and a summary of the results discussing whether or not archaeological or historical sites are known or suspected to exist within the site survey area and whether or not the site survey area has a previous archaeological investigation on record.

Records Check Attached
 Records Check Not Attached:
Justification:

Date of Records Check Conducted by Information Center:
Information Center File #:
Records Check Results:

CALIFORNIA FOREST PRACTICE RULES

Part III: NATIVE AMERICAN CONSULTATION INFORMATION

14 CCR Section 929.1 [949.1, 969.1] (a)(2) requires the RPF or the RPF's supervised designee to provide written notification to local Native American groups and individuals on the current list of Native American contacts provided by the Native American Heritage Commission, and to allow a minimum of 10 days for response prior to submitting a THP to CDF. This notice must: (A) request information concerning any archaeological or historical sites within the THP boundaries which may be known by Native Americans, (B) provide the project location by county, section, township and range, and the direction and distance from the nearest community or landmark, (C) provide an estimate of the earliest date CDF may approve the project, (D) include a statement that they may participate in the review process and provide the address and phone number of appropriate CDF offices to contact, (E) indicate that a Confidential Archaeological Addendum will be prepared and how a copy may be obtained, (F) provide a map with project boundary, legend, and scale, and (G) include the name of the USGS 7.5' map(s) upon which the project is located. Complete the following section and provide an example of the correspondence as an attachment to this report.

List the individuals or groups which were provided written notification:

Date notification was sent:

Results of notification :

- No reply received as of (date):**
- Written reply received (copy attached)**
- Verbal reply received (summarize reply below):**

Part IV: OTHER PRE-FIELD RESEARCH

Describe research conducted prior to field survey, other than the Archaeological Records Check and Native American consultation described in Parts II and III. For example, List the individuals or agencies which were contacted (such as the landowner, local archaeologist, etc.), the pertinent archaeological, ethnographic, or historical literature which was reviewed, and summarize the results of this research.

Literature Reviewed :

Persons Contacted:

Results of Pre-Field Research:

Part V: TRAINING AND EXPERIENCE OF ARCHAEOLOGICAL SURVEYOR(S)

Note: The information in Part V is not confidential and may be released to the public.

To meet the requirements of 14 CCR Section 929.1 [949.1, 969.1], archaeological surveys of THP's or EM's shall be conducted by a Professional Archaeologist or a person who has satisfactorily completed a CDF Archaeological Training Course within five years prior to submission of the project to CDF. Complete the following information:

Name of current Archaeological Surveyor(s):

- Archaeological Survey conducted by Professional Archaeologist**
- Archaeological Survey conducted by person with a current CDF Archaeological Training Certificate**

CDF Archaeological Training Course #

Date Completed:

- Archaeological Survey done for previous project within site survey area previously conducted by (provide name):**

Part VI: SURVEY METHODS AND PROCEDURES

Survey strategy:

Time spent conducting archaeological field survey:

Survey coverage intensity:

Ground visibility/other limitations:

Other relevant information:

CALIFORNIA FOREST PRACTICE RULES

Part VII: SURVEY RESULTS

List and briefly describe all archaeological or historical sites identified within the site survey area, including the site(s) size, type, and condition. Display the specific location of all identified archaeological or historical sites on the attached Archaeological Coverage Map or Maps. The designations used for the sites listed below (e.g. Site #1, Site #2, etc.) must correspond to the designations used in Parts VIII and IX, and to the site locations plotted on the Archaeological Coverage Map or Maps.

Survey Results:

Part VIII: EVALUATION OF SIGNIFICANCE

14 CCR Section 929.7 [949.7, 969.7] specifies that a determination of significance shall be made for an identified archaeological and historical site located within the site survey area if damaging effects from timber operations cannot be avoided. The determination of significance shall be based upon criteria defined for a "significant archaeological or historical site" found in 14 CCR Section 895.1, utilize any information provided by Native Americans, or found in any archaeological, historical, or ethnographic data pertinent to the region or to the site, and the physical characteristics of the site. If required, a preliminary determination of significance shall be made by the RPF or RPF's supervised designee and included in this report. The CDF Director shall make the final determination of significance, and substantial adverse change, based on advice of a professional archaeologist.

Preliminary Determination of Significance:

Part IX: PROTECTION MEASURES

List each archaeological or historical site identified within the project area and clearly describe the specific enforceable protection measures to be implemented, both within the site boundaries and within 100 feet of the site boundaries pursuant to 14 CCR 929.1 [949.1, 969.1] (b). In accordance with 14 CCR 929.2 [949.2, 969.2] (a), these are specific measures taken to mitigate or avoid substantial adverse change to any known significant archaeological or historical sites. The RPF may propose, and the Director may agree to, specific mitigation measures without evaluating the significance of any identified site.

Protection Measures:

Part X: MEETING WITH THE LICENSED TIMBER OPERATOR (LTO)

14 CCR Section 929.2 [949.2, 969.2] (b) requires the RPF or supervised designee familiar with on-site conditions to meet with the LTO prior to the start of timber operations at each archaeological or historical site that is described in the plan, or notice, that requires avoidance or protection measures, and do the following: (1) show the LTO the location, extent and boundaries of each archaeological or historical site requiring protection, (2) discuss with the LTO the protection measures, and (3) apprise the LTO of confidentiality requirements concerning the physical location of archaeological or historical sites. Pursuant to 14 CCR Section 929.2 [949.2, 969.2] (c), if the RPF or supervised designee familiar with on-site conditions is unable to perform these duties, the RPF shall: (1) explain the reasons in the THP, or THP amendment, or EM, (2) meet with the plan submitter, or if the plan submitter will not comply with the RPF's request for a meeting, notify the Director in writing, (3) except for EM's, notify the plan submitter in writing that it is the plan submitter's responsibility to transfer information to the LTO, and to notify the Director. Describe how this requirement has been or will be addressed:

Meeting with LTO:

- () **There are no archaeological or historical sites requiring protection, no meeting required.**
- () **Meeting between RPF or supervised designee familiar with on-site conditions and LTO will be conducted prior to start of timber operations.**
- () **Meeting between RPF or supervised designee familiar with on-site conditions and LTO has been conducted (provide details):**
- () **This RPF or supervised designee will not be meeting with the LTO.**

Provide information demonstrating compliance with 14CCR Section 929.2 [949.2, 969.2](c):

CALIFORNIA FOREST PRACTICE RULES

Part XI: SITE RECORDING

Any time prior to THP approval, or accompanying an EM larger than 3 acres, the RPF or RPF’s supervised designee shall submit completed site records for each site determined to be a significant archaeological or historical site [14 CCR Section 929.1 [949.1, 969.1] (c)], or for sites the surveyor elects to record but for which no determination of significance has been made [14 CCR 929.1 [949.1, 969.1] (f)]. Furthermore, the Director is responsible to ensure that all archaeological or historical sites determined to be significant and located within the site survey area on THP’s or EM’s larger than 3 acres are recorded in a manner consistent with the recording standards identified in OHP’s “Instructions for Recording Historical Resources.” Describe how these recording requirements have been or will be addressed:

- No sites found within the site survey area.**
- The following sites have been recorded and completed records are attached:**
- The following site(s) will be recorded prior to THP approval:**
- The following site(s) has been previously recorded, update(s) not prepared (attach copy(ies)):**
- The following site(s) has been previously recorded, update(s) prepared (attach copy(ies)):**
- The following sites will not be recorded, justification provided below:**

PART XII: OTHER APPLICABLE INFORMATION

Provide any additional information concerning the archaeological survey for this project:

Additional Information:

PART XIII: ATTACHMENTS

Indicate which attachments are included with this report. For THP’s, and EM’s of 3 acres or larger, the rules require the attachment of an Archaeological Coverage Map or Maps [14 CCR Sections 929.1 [949.1, 969.1] (b) [(8)] and 1052 (h)]. This map (or maps) shall contain a north arrow, a scale, and accurately display the project boundary, the site survey area (showing survey intensity(ies)), and specific location of all archaeological and historical sites identified within the site survey area. The map(s) must be on a 1:1 scale copy of a USGS 7.5' quadrangle(s), or digitally generated topographic equivalent. Additional maps at other scales may be included to more accurately display required information or increase clarity.

- | | |
|--|---|
| <input type="checkbox"/> Archaeological Records Check Request | <input type="checkbox"/> Archaeological Coverage Map (1:1 scale of USGS 7.5' quad) |
| <input type="checkbox"/> Archaeological Records Check Request Map | <input type="checkbox"/> Additional Archaeological Coverage Map(s) |
| <input type="checkbox"/> Information Center Reply | <input type="checkbox"/> Project Vicinity Map (optional) |
| <input type="checkbox"/> Example of Notice to Native Americans | <input type="checkbox"/> Written Reply from Native Americans |
| <input type="checkbox"/> USFS or other Agency Correspondence | <input type="checkbox"/> Site Records for: (specify which sites) |
| <input type="checkbox"/> Other: | <input type="checkbox"/> Photographs (optional) |

Part XIV: SUBMISSION OF APPROVED REPORT TO INFORMATION CENTER

Pursuant to 14 CCR Section 929.1 [949.1, 969.1] (f), the RPF or supervised designee, within 30 days following CDF’s approval of a THP or acceptance of an EM of larger than 3 acres, shall send to the appropriate Information Center the following:

- (1) A complete Confidential Archaeological Addendum which includes all changes and additions required in the THP review process, and which identifies the plan number, or for EM’s of three acres or larger, a Confidential Archaeological letter, and,
- (2) Two copies each of any completed archaeological or historical site records, for sites determined to be significant or for sites the surveyor elects to record but for which no determination of significance has been made.

Complete this section only after CDF approves the THP or after an EM is submitted to the Director.

THP plan number:

Emergency Notice number:

Date mailed to Information Center:

CALIFORNIA FOREST PRACTICE RULES

The amendments to 14 CCR § 895.1 adopted on March 15, 2000 and April 4, 2000, which became effective July 1, 2000, shall expire on December 31, 2002.

SUBCHAPTER 2 APPLICATION OF FOREST PRACTICE RULES

Article 1 Introduction

896 General

(a) The purpose of the Forest Practice Rules is to implement the provisions of the Z'berg-Nejedly Forest Practice Act of 1973 in a manner consistent with other laws, including but not limited to, the Timberland Productivity Act of 1982, the California Environmental Quality Act (CEQA) of 1970, the Porter Cologne Water Quality Act, and the California Endangered Species Act. The provisions of these rules shall be followed by Registered Professional Foresters (RPFs) in preparing Timber Harvesting Plans, and by the Director in reviewing such plans to achieve the policies described in Sections 4512, 4513, of the Act, 21000, 21001, and 21002 of the Public Resources Code (PRC), and Sections 51101, 51102 and 51115.1 of the Government Code.

It is the Board's intent that no THP shall be approved which fails to adopt feasible mitigation measures or alternatives from the range of measures set out or provided for in these rules which would substantially lessen or avoid significant adverse impacts which the activity may have on the environment. The THP process substitutes for the EIR process under CEQA because the timber harvesting regulatory program has been certified pursuant to PRC Section 21080.5. In recognition of that certification and PRC Section 4582.75, these rules are intended to provide the exclusive criteria for reviewing THPs. If the Director believes that there are significant adverse environmental impacts not covered in existing rules, matters should be referred to the Board as otherwise specified in these rules.

(b) The provisions of this subchapter shall be applied in all forest districts.

897 Implementation of Act Intent

(a) RPFs who prepare plans shall consider the range of feasible silvicultural system, operating methods and procedures provided in these rules in seeking to avoid or substantially lessen significant adverse effects on the environment from timber harvesting. RPFs shall use these rules for guidance as to which are the most appropriate feasible silvicultural systems, operating methods and procedures which will carry out the intent of the Act.

While giving consideration to measures proposed to reduce or avoid significant adverse impacts of THPs on lands zoned TPZ, the RPF and Director shall include the following legal consideration regarding feasibility:

The Timberland Productivity Act restricts use of lands zoned Timberland Production Zone to growing and harvesting timber and compatible uses and establishes a presumption that timber harvesting is expected to and will occur on such lands.

(b) In determining whether a THP conforms to the intent of the Act, the Director shall be guided by the following principles:

(1) The goal of forest management on a specific ownership shall be the production or maintenance of forests which are healthy and naturally diverse, with a mixture of trees and under-story plants, in which trees are grown primarily for the production of high quality timber products and which meet the following objectives:

(A) Achieve a balance between growth and harvest over time consistent with the harvesting methods within the rules of the Board.

(B) Maintain functional wildlife habitat in sufficient condition for continued use by the existing wildlife community within the planning watershed.

(C) Retain or recruit late and diverse seral stage habitat components for wildlife concentrated in the watercourse and lake zones and as appropriate to provide for functional connectivity between habitats.

(D) Maintain growing stock, genetic diversity, and soil productivity.

(2) Individual THPs shall be considered in the context of the larger forest and planning watershed in which they are located, so that biological diversity and watershed integrity are maintained within larger

CALIFORNIA FOREST PRACTICE RULES

planning units and adverse cumulative impacts, including impacts on the quality and beneficial uses of water are reduced.

(3) While the responsibility for implementation of the Act and rules belongs to the Director and the Department, RPFs who prepare plans have the responsibility to provide the Director with information about the plan and resource areas and the nature and purpose of the operations proposed which is sufficiently clear and detailed to permit the Director to exercise the discretion and make the determinations required by the Act and rules. The information in proposed plans shall also be sufficiently clear and detailed to permit adequate and effective review by responsible agencies and input by the public to assure that significant adverse individual and cumulative impacts are avoided or reduced to insignificance.

(c) The Director shall use the standards provided in these rules when reviewing plans to determine if they conform to the rules and regulations of the Board and the provisions of the Act. In specific circumstances provided in these rules, the Director shall disapprove plans because they conflict with the intent of the Act as interpreted by the Board.

(d) Due to the variety of individual circumstances of timber harvesting in California and the subsequent inability to adopt site-specific standards and regulations, these rules use judgmental terms in describing the standards that will apply in certain situations. By necessity, the RPF shall exercise professional judgment in applying these judgmental terms and in determining which of a range of feasible (see definition 14 CCR 895.1) silvicultural systems, operating methods and procedures contained in the rules shall be proposed in the plan to substantially lessen significant adverse impacts in the environment from timber harvesting. The Director also shall exercise professional judgment in applying these judgmental terms in determining whether a particular plan complies with the rules adopted by the Board and, accordingly, whether he or she should approve or disapprove a plan. The Director shall use these rules to identify the nature of and the limits to the professional judgment to be exercised by him or her in administering these rules.

(e) Based upon site-specific conditions where, in the judgment of the RPF, the application of rules pertaining to how a timber operation will be conducted will not achieve the intent of the Act and rules, and where the RPF can describe a practice(s) which will meet or exceed the intent of the Act and rules, the RPF may prescribe an alternative practice(s) in lieu of those in the rules. The practice(s) shall:

- (1) be explained and justified by clear and convincing evidence in the plan;
- (2) be written so they provide clear instructions and enforceable standards for the timber operator;
- (3) provide a result(s) at least equal to that of the rule(s) to be supplanted; and
- (4) provide that, where appropriate for the alternative practice, the plan submitter is responsible for retaining an RPF to aid in interpreting the THP to the timber operator and timberland owner on a continuing basis to help to assure compliance with the alternative.

(f) No alternative practice(s) as described in this section may be prescribed by an RPF or approved by the Director under this section in lieu of the following rules:

(1) The rules contained in Subchapter 2 (Application of Forest Practice Rules); Article 2 (Definitions, Ratings, and Standards) and Article 11 (Coastal Commission Special Treatment Areas) of Subchapter 4 (Coast Forest District Rules); Article 2 (Definitions, Ratings, and Standards) of Subchapter 5 (Northern Forest District Rules); Article 2 (Definitions, Ratings, and Standards) and Article 11 (Coastal Commission Special Treatment Areas) of Subchapter 6 (Southern Forest District Rules); and Subchapter 7 (Administration) of Chapter 4, Division 1.5 of the California Administrative Code; or

(2) Any rule pertaining to the width of the special treatment area adjacent to a wild and scenic river declared pursuant to PRC 5093.50, et seq.; or

(3) Any rules or parts of rules that incorporate practices or standards specified in the Forest Practice Act.

(g) No alternative practice as described in this section can be used in counties which have had rules adopted under section 4516.5 of the Public Resources Code unless it is specifically adopted for the county.

(h) The Director shall not accept for inclusion in a THP any alternative practice as described in this section where two or more agencies listed in 4582.6 of the PRC and 14 CCR 1037.3 have submitted written comments which lead the Director to the conclusion that the proposed alternative will not meet the intent of the Act and rules, and the agencies participated in the review of the plan, including any on-the-ground inspection.

CALIFORNIA FOREST PRACTICE RULES

Article 2 Preparation and Review of Timber Harvesting Plans

898 Feasibility Alternatives

After considering the rules of the Board and any mitigation measures proposed in the plan, the RPF shall indicate whether the operation would have any significant adverse impact on the environment. On TPZ lands, the harvesting per se of trees shall not be presumed to have a significant adverse impact on the environment. If the RPF indicates that significant adverse impacts will occur, the RPF shall explain in the plan why any alternatives or additional mitigation measures that would significantly reduce the impact are not feasible.

Cumulative impacts shall be assessed based upon the methodology described in Board Technical Rule Addendum Number 2, Forest Practice Cumulative Impacts Assessment Process and shall be guided by standards of practicality and reasonableness. The RPF's and plan submitter's duties under this section shall be limited to closely related past, present and reasonably foreseeable probable future projects within the same ownership and to matters of public record. The Director shall supplement the information provided by the RPF and the plan submitter when necessary to insure that all relevant information is considered.

When assessing cumulative impacts of a proposed project on any portion of a waterbody that is located within or downstream of the proposed timber operation and that is listed as water quality limited under Section 303(d) of the Federal Clean Water Act, the RPF shall assess the degree to which the proposed operations would result in impacts that may combine with existing listed stressors to impair a waterbody's beneficial uses, thereby causing a significant adverse effect on the environment. The plan preparer shall provide feasible mitigation measures to reduce any such impacts from the plan to a level of insignificance, and may provide measures, insofar as feasible, to help attain water quality standards in the listed portion of the waterbody.

The Director's evaluation of such impacts and mitigation measures will be done in consultation with the appropriate RWQCB.

(a) The amendments to 14 CCR § 898 that became effective July 1, 2000 shall expire on December 31, 2002.

898.1 Review of Plan by Director

The Director shall review plans to determine if they are in conformance with the provisions of PRC 4582.75 which requires that rules adopted by the Board shall be the only criteria employed by the Director in reviewing plans pursuant to PRC 4582.7.

(a) In reviewing plans, the Director shall apply all applicable rules promulgated by the Board.

(b) When in doubt as to the feasible alternative which best carries out the intent of the Act, the Director shall seek the advice of other state agencies charged with protecting the public interest in forest-related resources.

(c) In reviewing plans, the Director shall disapprove all plans which:

(1) Do not incorporate feasible silvicultural systems, operating methods and procedures that will substantially lessen significant adverse impacts on the environment.

(2) Would not meet the requirements of individual rules which provide a range of feasible alternatives through which to carry out the intent of the Act.

(3) Meet the special conditions for disapproval set by the Board in 14 CCR 898.2.

(d) If the Director, before the public comment period has ended, finds that a plan cannot be approved without a change in the conduct of timber operations, the Director shall, consistent with the rules and procedures adopted by the Board, communicate with the preparer of the plan, explain any probable causes for disapproval and suggest possible mitigation measures. The preparer of the plan shall then have the opportunity to respond to the Director and provide appropriate mitigation measures prior to the end of the public comment period. Any substantial deviations (as described in 895.1), except as covered in 1040, in the conduct of a timber operation, or the inclusion of significant new information, made between the close of public comment and the date of the Director's decision will require returning the plan to the review team and reopening the public comment period for ten working days. Public members who participated in the review of the plan will be notified of the significant changes in the conduct of the timber operation and/or the significant new information and the reopening of the comment period.

CALIFORNIA FOREST PRACTICE RULES

(e) If the Director disapproves a plan, the Director shall, consistent with the rules and procedures adopted by the Board, provide to the preparer of the plan written reasons for disapproval.

(f) If the Director finds no feasible, less-damaging alternatives that conform with the rules, the Director shall approve such plan unless approval threatens to cause immediate, significant, and long-term harm to the natural resources of the state. In the event of such a threat, the Director shall withhold decision on the plan and shall follow procedures developed by the Board pursuant to PRC 4555.

(g) If the Director determines that:

- 1) all feasible mitigation measures or alternatives which are available to substantially reduce or avoid any significant adverse impacts of a THP have been selected;
- 2) significant adverse impacts remain;
- 3) the plan otherwise complies with the rules of the Board; and
- 4) an emergency situation does not exist under PRC Section 4555, the Director shall not approve the plan unless the Director also determines that the benefits of the THP outweigh any significant, unavoidable adverse impacts. If the Director makes such a determination and approves the THP, the Notice of Conformance shall include an explanation of the basis for finding that the conditions 1-3 herein are met and for determining that the THP's benefits outweigh any unavoidable significant adverse impacts.

In making such a determination for THPs on lands zoned TPZ the Director shall give consideration to the Legislature's objectives in enacting the Timberland Productivity Act of 1982 ("TPA") and the objectives of the FPA including sustained forest productivity. The TPA-associated benefits to be weighed against any significant avoidable adverse impacts shall include, but not be limited to:

- (1) Ensuring consistency with the restriction of the use of TPZ lands to growing and harvesting timber and compatible uses;

- (2) Making cumulative progress toward:

- (a) realizing the productive potential of the forest resources of the state and

- (b) providing a favorable climate for long-term investment in forest resources, thereby discouraging the premature and unnecessary conversion of timberland to urban and other uses; and

- (3) Ensuring consistency with the Legislature's declaration that timber operations may reasonably be expected to and will occur on lands zoned TPZ.

(h) In determining whether the public benefits of the THP outweigh any unavoidable significant adverse impacts pursuant to (g) above, the Director may request information as needed to evaluate potential job loss, negative economic impacts on the community, business closings, loss of property by owners, probable conversion to other uses, estate taxes and other factors as appropriate.

898.2 Special Conditions Requiring Disapproval of Plans

The Director shall disapprove a plan as not conforming to the rules of the Board if any one of the following conditions exist:

- (a) Boundaries of the area to be harvested are not clearly delineated in the plan.

- (b) Public acquisition of the parcel for purposes which would be impaired by timber harvesting, is legislatively authorized, funded and imminent.

- (c) There is evidence that the information contained in the plan is incorrect, incomplete or misleading in a material way, or is insufficient to evaluate significant environmental effects. The sufficiency of the information provided in a THP to evaluate significant environmental effects shall be judged in light of what is reasonable and necessary.

- (d) Implementation of the plan as proposed would result in either a "taking" or finding of jeopardy of wildlife species listed as rare, threatened or endangered by the Fish and Game Commission, the National Marine Fisheries Service, or Fish and Wildlife Service, or would cause significant, long-term damage to listed species. The Director is not required to disapprove a plan which would result in a "taking" if the "taking" is incidental and is authorized by a wildlife agency acting within its authority under state or federal endangered species acts.

- (e) Implementation of the plan would irreparably damage plant species listed as rare or endangered by the Department of Fish and Game and when the timber owner fails to comply with F&GC 1913.

- (f) Implementation of the plan as proposed would result in the taking of an individual Northern Spotted Owl prohibited by the Federal Endangered Species Act.

- (g) Implementation of the plan as proposed would not achieve maximum sustained production of high quality timber products as provided for by the rules of the Board, and by the intent of the Act.

CALIFORNIA FOREST PRACTICE RULES

(h) Implementation of the plan as proposed would cause a violation of any requirement of an applicable water quality control plan adopted or approved by the State Water Resources Control Board.

Article 3 PRC 4555, Rule Review Procedures

900 Intent

Regulations set forth in this article are adopted pursuant to Legislative direction set forth in PRC 4552 and 4555 and to provide a hearing procedure as mandated in PRC 4555.

901 Timber Harvesting Plan Decision Delay

The Director shall delay making a decision to approve or disapprove a plan which has been filed only if he or she finds that it could result in immediate, significant and long-term harm to the natural resources of the state. In relation to ascertaining harm to the natural resources of the state, the words immediate, significant and long-term shall be construed to mean:

- (a) "Immediate"- a period of time from the present to some future date that shall not be later than the end of the third timber harvest season following commencement of timber operations under a proposed plan.
- (b) "Significant"- harm or damage which is substantial and threatens the use of forest-related benefits (i.e., other beneficial uses of the air, water, soil, fish or wildlife resources).
- (c) "Long-term"- harm or damage that is of such a nature and of lasting duration which cannot be corrected within 3 timber harvest seasons following commencement of timber operations under a proposed plan.

902 Director's Notice to Board

If the Director determines that a substantial question concerning the intent of the Act is not currently provided for by the rules of the Board, and that approval of a plan which has been filed could result in immediate, significant and long-term harm to the natural resources of the State, the Director shall within 5 days after making such determination, notify the Board and the person who submitted the plan in writing of his or her determination. Written notice to the Board shall:

- (a) State that the Director is seeking an emergency determination by the Board pursuant to PRC 4555.
- (b) Outline the substantial question concerning intent of the Act that is not currently provided for by the rules.
- (c) Identify any particular rule or rules which may be in question with respect to the intent of the Act.
- (d) Identify any other provisions of law which apply to the Director's decision to delay.

902.1 Board Action

Within 30 days after receipt of written notice from the Director that he or she had delayed making a decision to approve or disapprove a plan pursuant to PRC 4555, and 14 CCR 901, the Board will hold a public hearing on the issue raised by the Director in said notice. Thereafter the Board may adopt emergency regulations in the manner provided by the Administrative Procedure Act (commencing with Gov. C. 11420) and shall conform to specifications enumerated in 14 CCR 902.2, 902.3, 903 and 903.1.

902.2 Notice Content

The Notice of Public Hearing on issues raised pursuant to provisions of PRC 4555 shall contain substantially the same information as provided to the Board pursuant to 14 CCR 902.

902.3 Notice Distribution

Notice of public hearing on issues raised by the Director pursuant to provisions of PRC 4555 shall be given at least 15 days prior to said hearing and be distributed as follows by:

- (a) Mailing such notice to concerned federal, state and local agencies of government;
- (b) Providing for mailing to timber owners, operators, and foresters (RPFs), who have plans held in abeyance by the Director pending action by the Board under PRC 4555.
- (c) Providing for dissemination to the agenda mailing list of the Board and other parties as may be determined to be appropriate by the Executive Officer to provide full public participation in the hearing.

CALIFORNIA FOREST PRACTICE RULES

903.1 Content of Discussion and Prejudice of Appeal

In considering the need for possible emergency regulations, as well as the emergency regulations themselves, the Board normally will consider all relevant information. However, to avoid prejudicing future appeals on individual plans, the proceeding shall be addressed solely to the generic issue(s) presented by the Director.

903.2 Board Action

Immediately after public comments the Board shall determine whether or not the intent of the Act has been provided for in the rules effective at the time the Director's determination was made. If the Board finds the existing rules are adequate, it shall adopt a finding so stating.

If the Board finds that the intent of the Act has not been provided for in such rules, the Board shall comply with the provisions of PRC 4555 and immediately amend the rules to provide for such intent by adopting emergency regulations pursuant to the Administrative Procedure Act (commencing with Gov. C. 11371). The Board shall advise the Director by letter of the action taken and provide a copy of the emergency regulations indicating that they will become effective upon filing with the Secretary of State.

In either case, the Director shall act within 5 days after receipt of said letter on plans being held in abeyance pending Board consideration.

SUBCHAPTER 3 FOREST DISTRICT BOUNDARIES

Article 1 Districts

906 Forest Districts

To meet the requirements of Chapter 8, Article 3 (commencing with Section 4531), Public Resources Code, and to designate areas for appropriate special forest practice rules, the nonfederally-owned commercial forest areas of the state are divided into three districts which are designated as Coast Forest District, Northern Forest District, and Southern Forest District. Each district is comprised of timberlands and cutover lands within the boundaries as set forth in this article.

907 Coast Forest District

The Coast Forest District is comprised of the area bounded on the north by the State of Oregon, on the west by the Pacific Ocean, and on the south and east by a line declared and fixed as follows:

Beginning at the southwest corner of Santa Cruz County and running eastward along the southern boundaries of Santa Cruz and Santa Clara Counties to U.S. Highway 101; thence northerly along U.S. Highway 101 to Interstate Highway 680; thence northerly along Interstate Highway 680 to Interstate Highway 80; thence southerly along Interstate Highway 80 to State Highway 29 between Vallejo and the Carquinez Bridge; thence northerly along State Highway 29 to State Highway 128 at Rutherford; thence northerly along coinciding State Highways 29 and 128 to the junction of State Highways 29 and 128 at Calistoga; thence northwesterly along State Highway 128 to U.S. Highway 101; thence northerly along U.S. Highway 101 to the Covelo Road (State Highway 162, formerly designated 261); thence northeasterly along the Covelo Road to Mina Road (Mendocino County Road 336) just north of Covelo; thence northerly from Mendocino County into Trinity County along Mina Road, where it continues as Lake Mountain Road (Trinity County Road 503); continuing along Lake Mountain Road northwesterly through Kettenpom to the Ruth-Zenia Road (Trinity County Road 502) just southeast of Zenia, thence easterly and northerly along the Ruth-Zenia Road to the Van Duzen Road (Trinity County Road 511) at the Van Duzen River on the northwest side of Hettenshaw Valley; thence along the Van Duzen Road, following along a fork of the Van Duzen River and the main Van Duzen River northwesterly and northerly to State Highway 36, thence southeasterly along State Highway 36 to the South Fork of the Trinity River, thence northerly along the South Fork of the Trinity River and the main Trinity River to the Klamath River, thence northeasterly, then northerly along the Klamath River to the mouth of Indian Creek; thence northerly along Indian Creek to the crossing of State Highway 96; thence northeasterly along State Highway 96 to the Indian Creek Road (Siskiyou County Road 7C01); thence northwesterly along the Indian Creek Road following along Indian Creek to the crossing of Indian Creek in the south half of Section 25, Township 18N, Range 6E, HB&M, from whence the Indian Creek County Road continues as the U.S. Forest Service Grayback Road (U.S.

CALIFORNIA FOREST PRACTICE RULES

Forest Service Road 40S07); continuing northwesterly along the Forest Service Grayback Road over the divide at the head of Indian Creek to the State of Oregon in Section 32, Township 19N, Range 6E, HB&M.

908 Northern Forest District

The Northern Forest District is comprised of the area bounded on the north by the State of Oregon, on the east by the State of Nevada, on the west by the Coast Forest District, and on the south by a line declared and fixed as follows:

Beginning at the point where Interstate Highway 680 crosses the combined San Joaquin-Sacramento Rivers at the Benicia Bridge; thence easterly along the channel to the mouth of the Sacramento River; thence easterly and northerly along the Sacramento River to the Sacramento-Sutter County line; thence easterly along said county line to the Sacramento-Placer County line; thence easterly along said county line to the Placer-EI Dorado County line; thence northerly and easterly along said county line to the intersection with the Lake Tahoe Basin crestline; thence northerly and then easterly along said crestline to its intersection with the west boundary of Section 10; thence north along the west boundary of Section 10 and Section 3 to the northwest corner of Section 3; thence east along the north boundary of Section 3 and Section 2 to the Lake Tahoe Basin crestline, all Sections being in Township 15N, Range 16E, MDB&M; thence northerly and easterly along said crestline to the State of Nevada.

909 Southern Forest District

The Southern Forest District is comprised of the area bounded on the north by the Northern Forest District, on the west by the Coast Forest District and the Pacific Ocean south of Santa Cruz County, on the east by the States of Nevada and Arizona, and on the south by Mexico.

909.1 High Use Subdistrict

The "High Use Subdistrict" of the Southern Forest District includes the Counties of Ventura, Santa Barbara, Los Angeles, San Bernardino, Orange, Riverside, Imperial, San Diego, Monterey, San Luis Obispo, and those portions of Placer and El Dorado lying within the authority of the Tahoe Regional Planning Agency. In this subdistrict, the growing of commercial timber is subjected to pressures for competing land uses, such as recreation, water, and urbanization.

SUBCHAPTERS 4, 5 & 6 FOREST DISTRICT RULES

Article 1 Introduction

911, 931, 951 Statement of Purpose [All Districts]

The purpose of these rules is to establish district forest practice rules and to establish standards in accordance with the policies set forth in Articles 1 and 4 of the Z'berg-Nejedly FPA of 1973 (Sections 4511-4517 and 4551-4555 incl. of the PRC). Rules promulgated herein apply only to timberlands.

Article 2 Ratings and Standards

912.5 Procedure for Estimating Surface Soil Erosion Hazard Rating [Coast]

A proposed plan shall show the estimated erosion hazard ratings of the plan area, by areas, down to 20 acres (8.1 ha) if such a breakdown will change the estimated erosion hazard of individual areas. The plan shall show high and extreme erosion hazard ratings, by areas, down to 10 acres if such a breakdown will change the erosion hazard of the individual areas. Specific erosion hazard areas not fitting the above minimum will be considered independently and protective measures commensurate with the problem applied. These measures are covered in Chapter 4, Subchapter 4 of Title 14, CCR.

To estimate the erosion hazard rating of any plan or portion thereof, the RPF or supervised designee shall follow the procedures and requirements contained in Board Technical Rule Addendum #1, dated February 1, 1990. Appropriate weights for the factors in the Estimated Surface Soil Erosion Hazard, Form I, in the Addendum, shall be calculated and the factors shall be summed to give the rating. A copy of the calculations from Form I shall be attached to the timber harvesting plan. A copy of the Board Technical Rule Addendum #1 can be obtained from the State Board of Forestry [*and Fire Protection*] at the Resources Building, 1416

CALIFORNIA FOREST PRACTICE RULES

9th Street, Room 1506-14, [P.O. Box 944246,] Sacramento, CA [94244-2460].

932.5, 952.5 Procedure for Estimating Surface Soil Erosion Hazard Rating [Northern, Southern]

A proposed plan shall show the estimated erosion hazard ratings of the plan area, by areas, down to 20 acres (8.1 ha) if such a breakdown will change the estimated erosion hazard of individual areas.

To estimate the erosion hazard rating of any plan or portion thereof, the RPF or supervised designee shall follow the procedures and requirements contained in Board Technical Rule Addendum #1, dated February 1st, 1990. Appropriate weights for the factors in the Estimated Surface Soil Erosion Hazard, Form I, in the Addendum shall be calculated and the factors shall be summed to give the rating. A copy of the calculations from Form I shall be attached to the timber harvesting plan. A copy of the Board Technical Rule Addendum #1 can be obtained from the State Board of Forestry [and Fire Protection] at the Resources Building, 1416 9th Street, Room 1506-14, [P.O. Box 944246,] Sacramento, CA [94244-2460].

912.7, 932.7, 952.7 Resource Conservation Standards for Minimum Stocking [All Districts, note (b)(1)(D)]

The following resource conservation standards constitute minimum acceptable stocking in the Coast (Northern, Southern) Forest District after timber operations have been completed.

(a) Rock outcroppings, meadows, wet areas, or other areas not normally bearing commercial species shall not be considered as requiring stocking and are exempt from such provisions.

(b) An area on which timber operations have taken place shall be classified as acceptably stocked if either of the standards set forth in (1) or (2) below are met within five years after completion of timber operations unless otherwise specified in the rules.

(1) An area contains an average point count of 300 per acre on Site I, II and III lands or 150 on site IV and V land to be computed as follows:

(A) Each countable tree (Ref. CCR, Title 14, Sec. 895.1) which is not more than 4 inches d.b.h. counts 1 point.

(B) Each countable tree over 4 in. but less than 12 in. d.b.h. counts 3 points.

(C) Each countable tree over 12 inches d.b.h. counts as 6 points.

(D) Root crown sprouts over 1 ft. in height will be counted, using the average stump diameter at 1 ft. above the average ground level of the original stump, counting 1 sprout for each ft. of stump diameter to a maximum of 6 per stump.

(2) The average residual basal area measured in stems 1 in. or larger in diameter, is at least 85 square ft. per acre on Site I lands, and 50 square ft. per acre on lands of Site II classification or lower. Site classification shall be determined by the RPF who prepared the plan.

(c) The resource conservation standards of the rules may be met with Group A and/or B commercial species. The percentage of the stocking requirements met with Group A species shall be no less than the percentage of the stand basal area they comprised before harvesting. The site occupancy provided by Group A species shall not be reduced relative to Group B species. When considering site occupancy, the Director shall consider the potential long term effects of relative site occupancy of Group A species versus Group B species as a result of harvest. If Group A species will likely recapture the site after harvest, Group B species do not need to be reduced. The time frames for recapturing the site shall be consistent with achieving MSP. The Director may prohibit the use of Group A and/or B commercial species which are non-indigenous or are not physiologically suited to the area involved. Exceptions may be approved by the Director if the THP provides the following information and those exceptions are agreed to by the timberland owner:

(1) Explain and justify with clear and convincing evidence how using Group A nonindigenous, or Group B species to meet the resource conservation standards will meet the intent of the Forest Practice Act as described in PRC Sec. 4513. The discussion shall include at least:

(A) The management objectives of the post-harvest stand;

(B) A description of the current stand, including species composition and current stocking levels within the area of Group B species. The percentage can be measured by using point-count, basal area, stocked plot, or other method agreed to by the Director.

(C) The percentage of the post-harvest stocking to be met with Group B species. Post harvest percentages will be determined on the basis of stocked plots. Only the methods provided by 14 CCR 1070-1075 shall be used in determining if the standards of PRC Sec. 4561 have been met.

CALIFORNIA FOREST PRACTICE RULES

(D) A description of what will constitute a countable tree, as defined by PRC Sec. 4528 for a Group B species and how such a tree will meet the management objectives of the post-harvest stand. The Director, after an initial inspection pursuant to PRC Section 4604, shall approve use of Group B species, as exceptions to the pre-harvest basal area percentage standard, if in his judgment the intent of the Act will be met, and there will not be an immediate significant and long-term harm to the natural resources of the state.

912.8 Progeny, Clonal, or Provenance Testing Stocking Standard Exemption [Coast only]

Pursuant to PRC 4561.7, the following standards shall apply to the request for an exemption from the stocking standards of the Act for Progeny, clonal, or provenance testing.

(a) Any THP submitted pursuant to Sec. 4561.7 of the PRC shall include the following information, in addition to other requirements of the rules of the Board:

- (1) A specific request for an exemption from stocking standards; and
- (2) A description of the testing to be conducted on the site.

(b) The exemption from stocking shall become effective upon the Director's determination that the timber harvesting plan is in conformance with the rules and regulations of the Board.

CALIFORNIA FOREST PRACTICE RULES

912.9, 932.9, 952.9 Cumulative Impacts Assessment Checklist [All Districts]

STATE OF CALIFORNIA BOARD OF FORESTRY CUMULATIVE IMPACTS ASSESSMENT

(1) Do the assessment area(s) of resources that may be affected by the proposed project contain any past, present, or reasonably foreseeable probable future projects? Yes ___ No ___

If the answer is yes, identify the project(s) and affected resource subject(s).

(2) Are there any continuing, significant adverse impacts from past land use activities that may add to the impacts of the proposed project? Yes ___ No ___ If the answer is yes, identify the activities, describing their location, impacts and affected resource subject(s).

(3) Will the proposed project, as presented, in combination with past, present, and reasonably foreseeable probable future projects identified in items (1) and (2) above, have a reasonable potential to cause or add to significant cumulative impacts in any of the following resource subjects?

	Yes after mitigation (a)	No after mitigation (b)	No reasonably potential significant effects (c)
1. Watershed			
2. Soil Productivity			
3. Biological			
4. Recreation			
5. Visual			
6. Traffic			
7. Other			

a) Yes, means that potential significant adverse cumulative impacts are left after application of the forest practice rules and mitigations or alternatives proposed by the plan submitter.
 b) No after mitigation means that any potential for the proposed timber operation to cause or add to significant adverse cumulative impacts by itself or in combination with other projects has been reduced to insignificance or avoided by mitigation measures or alternatives proposed in the THP and application of the forest practice rules.
 c) No reasonably potential significant cumulative effects means that the operations proposed under the THP do not have a reasonable potential to join with the impacts of any other project to cause, add to, or constitute significant adverse cumulative impacts.

(4) If column (a) is checked in (3) above describe why the expected impacts cannot be feasibly mitigated or avoided and what mitigation measures or alternatives were considered to reach this determination. If column (b) is checked in (3) above describe what mitigation measures have been selected which will substantially reduce or avoid reasonably potential significant cumulative impacts except for those mitigation measures or alternatives mandated by application of the rules of the Board.

(5) Provide a brief description of the assessment area used for each resource subject.

(6) List and briefly describe the individuals, organizations, and records consulted in the assessment of cumulative impacts for each resource subject. Records of the information used in the assessment shall be provided to the Director upon request.

CALIFORNIA FOREST PRACTICE RULES

BOARD OF FORESTRY TECHNICAL RULE ADDENDUM NO. 2 CUMULATIVE IMPACTS ASSESSMENT

Introduction

The purpose of this addendum is to guide the assessment of cumulative impacts as required in 14 CCR 898 and 1034 that may occur as a result of proposed timber operations. This assessment shall include evaluation of both on-site and off-site interactions of proposed project activities with the impacts of past and reasonably foreseeable future projects.

In conducting an assessment, the RPF must distinguish between on-site impacts that are mitigated by application of the Forest Practice Rules and the interactions of proposed activities (which may not be significant when considered alone) with impacts of past and reasonably foreseeable future projects.

Resource subjects to be considered in the assessment of cumulative impacts are described in the Appendix.

The RPF preparing a THP shall conduct an assessment based on information that is reasonably available before submission of the THP. RPFs are expected to submit sufficient information to support their findings if significant issues are raised during the Department's review of the THP.

Information used in the assessment of cumulative impacts may be supplemented during the THP review period. Agencies participating in plan review may provide input into the cumulative impacts assessment based upon their area of expertise. Agencies should support their recommendations with documentation.

The Department, as lead agency, shall make the final determination regarding assessment sufficiency and the presence or absence of significant cumulative impacts. This determination shall be based on a review of all sources of information provided and developed during review of the Timber Harvesting Plan.

Identification of Resource Areas

The RPF shall establish and briefly describe the geographic assessment area within or surrounding the plan for each resource subject to be assessed and shall briefly explain the rationale for establishing the resource area. This shall be a narrative description and shall be shown on a map where a map adds clarity to the assessment.

Identification of Information Sources

The RPF shall list and briefly describe the individuals, organizations, and records used as sources of information in the assessment of cumulative impacts, including references for listed records and the names, affiliations, addresses, and phone numbers of specific individuals contacted. Records of information used in the assessment shall be provided to the Director upon request.

Common sources of information for cumulative effects assessment are identified below. Sources to be used will depend upon the complexity of individual situations and the amount of information available from other plans. Sources not listed below may have to be consulted based on individual circumstances. Not all sources of information need to be consulted for every THP.

1. Consultation with Experts and Organizations:

- | | |
|---------------------------------|-----------------------------------|
| (a) County Planning Department; | (b) Biologists; |
| (c) Geologists; | (d) Soil Scientists; |
| (e) Hydrologists; | (f) Federal Agencies; |
| (g) State Agencies; | (h) Public and private utilities. |

2. Records Examined:

- | | |
|--|------------------------------------|
| (a) Soil Maps; | (b) Geology Maps; |
| (c) Aerial Photographs; | (d) Natural Diversity Data Base; |
| (e) THP Records; | (f) Special Environmental Reports; |
| (g) Basin Plans; | (h) Fire History Maps; |
| (i) Relevant Federal Agency Documents or Plans | |

CALIFORNIA FOREST PRACTICE RULES

As provided in Section 898 of the rules, the RPF or supervised designee and the plan submitter must consult information sources that are reasonably available.

Past and Future Activities

Past and future projects included in the cumulative impacts assessment shall be described as follows:

A. Identify and briefly describe the location of past and reasonably foreseeable probable future projects as defined in 14 CCR 895.1 within described resource assessment areas.

B. Identify and give the location and description of any known, continuing significant environmental problems caused by past projects as defined in 14 CCR 895.1.

The RPF who prepares the plan or supervised designee shall obtain information from plan submitters (timberland or timber owner), and from appropriate agencies, landowners, and individuals about past, and future land management activities and shall consider past experience, if any, in the assessment area related to past impacts and the impacts of the proposed operations, rates of recovery, and land uses. A poll of adjacent land owners is encouraged and may be required by the Director to determine such activities and significant adverse environmental problems on adjacent ownerships.

Appendix Technical Rule Addendum # 2

In evaluating cumulative impacts, the RPF shall consider the factors set forth herein.

A. Watershed Resources

Cumulative Watershed Effects (CWEs) occur within and near bodies of water or significant wet areas, where individual impacts are combined to produce an effect that is greater than any of the individual impacts acting alone. Factors to consider in the evaluation of cumulative watershed impacts are listed below.

1. Impacts to watershed resources within the Watershed Assessment Area (WAA) shall be evaluated based on significant on-site and off-site cumulative effects on beneficial uses of water, as defined and listed in applicable Water Quality Control Plans.

2. Watershed effects produced by timber harvest and other activities may include one or more of the following:

- Sediment
- Water temperature
- Organic debris
- Chemical contamination
- Peak flow

The following general guidelines shall be used when evaluating watershed impacts. The factors described are general and may not be appropriate for all situations. Actual measurements may be required if needed to evaluate significant environmental effects. The plan must comply with the quantitative or narrative water-quality objectives set forth in an applicable Water Quality Control Plan.

a. Sediment Effects. Sediment-induced CWEs occur when earth materials transported by surface or mass wasting erosion enter a stream or stream system at separate locations and are then combined at a downstream location to produce a change in water quality or channel condition. The eroded materials can originate from the same or different projects. Potentially adverse changes are most likely to occur in the following locations and situations:

- Downstream areas of reduced stream gradient where sediment from a new source may be deposited in addition to sediment derived from existing or other new sources.

- Immediately downstream from where sediment from a new source is combined with sediment from other new or existing sources and the combined amount of sediment exceeds the transport capacity of the stream.

- Any location where sediment from new sources in combination with suspended sediment from existing or other new sources significantly reduces the survival of fish or other aquatic organisms or reduces the quality of waters used for domestic, agricultural, or other beneficial uses.

CALIFORNIA FOREST PRACTICE RULES

- Channels with relatively steep gradients which contain accumulated sediment and debris that can be mobilized by sudden new sediment inputs, such as debris flows, resulting in debris torrents and severe channel scouring.

Potentially significant adverse impacts of cumulative sediment inputs may include:

- Increased treatment needs or reduced suitability for domestic, municipal, industrial, or agricultural water use.
- Direct mortality of fish and other aquatic species.
- Reduced viability of aquatic organisms or disruption of aquatic habitats and loss of stream productivity caused by filling of pools and plugging or burying streambed gravel.
- Accelerated channel filling (aggradation) resulting in loss of streamside vegetation and stream migration that can cause accelerated bank erosion.
- Accelerated filling of downstream reservoirs, navigable channels, water diversion and transport facilities, estuaries, and harbors.
- Channel scouring by debris flows and torrents.
- Nuisance to or reduction in water related recreational activities.

Situations where sediment production potential is greatest include:

- Sites with high or extreme erosion hazard ratings.
- Sites which are tractor logged on steep slopes.
- Unstable areas.

b. Water Temperature Effect. Water temperature related CWEs are changes in water chemistry or biological properties caused by the combination of solar warmed water from two or more locations (in contrast to an individual effect that results from impacts along a single stream segment) where natural cover has been removed. Cumulative changes in water temperature are most likely to occur in the following situations:

- Where stream bottom materials are dark in color.
- Where water is shallow and has little underflow.
- Where removal of streamside canopy results in substantial, additional solar exposure or increased contact with warm air at two or more locations along a stream.
- Where removal of streamside canopy results in substantial, additional solar exposure or increased contact with warm air at two or more streams that are tributary to a larger stream.
- Where water temperature is near a biological threshold for specific species.

Significant adverse impacts of cumulative temperature increases include:

- Increases in the metabolic rate of aquatic species.
- Direct increases in metabolic rate and/or reduction of dissolved oxygen levels, either of which can cause reduced vigor and death of sensitive fish and other sensitive aquatic organisms.
- Increased growth rates of microorganisms that deplete dissolved oxygen levels or increased disease potential for organisms.
- Stream biology shifts toward warmer water ecosystems.

c. Organic Debris Effects. CWEs produced by organic debris can occur when logs, limbs, and other organic material are introduced into a stream or lake at two or more locations. Decomposition of this debris, particularly the smaller sized and less woody material, removes dissolved oxygen from the water and can cause impacts similar to those resulting from increased water temperatures. Introduction of excessive small organic debris can also increase water acidity.

Large organic debris is an important stabilizing agent that should be maintained in small to medium size, steep gradient channels, but the sudden introduction of large, unstable volumes of bigger debris (such as logs, chunks, and larger limbs produced during a logging operation) can obstruct and divert streamflow against erodible banks, block fish migration, and may cause debris torrents during periods of high flow.

Removing streamside vegetation can reduce the natural, annual inputs of litter to the stream (after decomposition of logging-related litter). This can cause both a drop in food supply, and resultant productivity, and a change in types of food available for organisms that normally dominate the lower food chain of streams with an overhanging or adjacent forest canopy.

CALIFORNIA FOREST PRACTICE RULES

d. Chemical Contamination Effects. Potential sources of chemical CWEs include run-off from roads treated with oil or other dust-retarding materials, direct application or run-off from pesticide treatments, contamination by equipment fuels and oils, and the introduction of nutrients released during slash burning or wildfire from two or more locations.

e. Peak Flow Effects. CWEs caused by management induced peak flow increases in streams during storm events are difficult to anticipate. Peak flow increases may result from management activities that reduce vegetative water use or produce openings where snow can accumulate (such as clear-cutting and site preparation) or that change the timing of flows by producing more efficient runoff routing (such as insloped roads). These increases, however, are likely to be small relative to natural peak flows from medium and large storms. Research to date on the effects of management activities on channel conditions indicates that channel changes during storm events are primarily the result of large sediment inputs.

3. Watercourse Condition. The watershed impacts of past upstream and on-site projects are often reflected in the condition of stream channels on the project area. Following is a list of channel characteristics and factors that may be used to describe current watershed conditions and to assist in the evaluation of potential project impacts:

◇ Gravel Embedded - Spaces between stream gravel filled with sand or finer sediments. Gravel are often in a tightly packed arrangement.

◇ Pools Filled - Former pools or apparent pool areas filled with sediments leaving few areas of deep or "quiet" water relative to stream flow or size.

◇ Aggrading - Stream channels filled or filling with sediment that raises the channel bottom elevation. Pools will be absent or greatly diminished and gravel may be embedded or covered by finer sediments. Streamside vegetation may be partially or completely buried, and the stream may be meandering or cutting into its banks above the level of the former streambed. Depositional areas in aggrading channels are often increasing in size and number.

◇ Bank Cutting - Can either be minor or severe and is indicated by areas of fresh, unvegetated soil or alluvium exposed along the stream banks, usually above the low-flow channel and often with a vertical or undercut face. Severe bank cutting is often associated with channels that are downcutting, which can lead to over-steepened banks, or aggrading, which can cause the channel to migrate against slopes that were previously above the high flow level of the stream.

◇ Bank Mass Wasting - Channels with landslides directly entering the stream system. Slide movement may be infrequent (single events) or frequent (continuing creep or periodic events).

◇ Downcutting - Incised stream channels with relatively clean, uncluttered beds cut below the level of former streamside vegetation and with eroded, often undercut or vertical, banks.

◇ Scoured - Stream channels that have been stripped of gravel and finer bed materials by large flow events or debris torrents. Streamside vegetation has often been swept away, and the channel has a raw, eroded appearance.

◇ Organic Debris - Debris in the watercourse can have either a positive or negative impact depending on the amount and stability of the material. Some stable organic debris present in the watercourse helps to form pools and retard sediment transport and downcutting in small to medium sized streams with relatively steep gradients. Large accumulations of organic debris can block fish passage, block or divert streamflow, or could be released as a debris flow.

◇ Stream-Side Vegetation - Stream-side vegetation and near-stream vegetation provide shade or cover to the stream, which may have an impact on water temperature, and provides root systems that stabilize streambanks and floodplains and filter sediment from flood flows.

◇ Recent Floods - A recent high flow event that would be considered unusual in the project area may have an impact on the current watercourse condition.

B. Soil Productivity

Cumulative soil productivity impacts occur when the effects of two or more activities, from the same or different projects, combine to produce a significant decrease in soil biomass production potential. These impacts most often occur on-site within the project boundary, and the relative severity of productivity losses for a given level of impact generally increases as site quality declines. The primary factors influencing soil productivity that can be affected by timber operations include:

CALIFORNIA FOREST PRACTICE RULES

- ◇ Organic matter loss.
- ◇ Surface soil loss.
- ◇ Soil compaction.
- ◇ Growing space loss.

The following general guidelines may be used when evaluating soil productivity impacts.

1. Organic Matter Loss. Displacement or loss of organic matter can result in a long term loss of soil productivity. Soil surface litter and downed woody debris are the store-house of long term soil fertility, provide for soil moisture conservation, and support soil microorganisms that are critical in the nutrient cycling and uptake process. Much of the chemical and microbial activity of the forest nutrient cycle is concentrated in the narrow zone at the soil and litter interface.

Displacement of surface organic matter occurs as a result of skidding, mechanical site preparation, and other land disturbing timber operations. Actual loss of organic matter occurs as a result of burning or erosion. The effects of organic matter loss on soil productivity may be expressed in terms of the percentage displacement or loss as a result of all project activities.

2. Surface Soil Loss. The soil is the storehouse of current and future site fertility, and the majority of nutrients are held in the upper few inches of the soil profile. Topsoil displacement or loss can have an immediate effect on site productivity, although effects may not be obvious because of reduced brush competition and lack of side-by-side comparisons or until the new stand begins to fully occupy the available growing space.

Surface soil is primarily lost by erosion or by displacement into windrows, piles, or fills. Mass wasting is a special case of erosion with obvious extreme effects on site productivity. The impacts of surface soil loss may be evaluated by estimating the proportion of the project area affected and the depth of loss or displacement.

3. Soil Compaction. Compaction affects site productivity through loss of large soil pores that transmit air and water in the soil and by restricting root penetration. The risk of compaction is associated with:

- Depth of surface litter.
- Soil organic matter content.
- Soil texture.
- Soil structure.
- Presence and amount of coarse fragments in the soil.
- Soil moisture status.

Compaction effects may be evaluated by considering the soil conditions, as listed above, at the time of harvesting activities and the proportion of the project area subjected to compacting forces.

4. Growing Space Loss. Forest growing space is lost to roads, landings, permanent skid trails, and other permanent or non-restored areas subjected to severe disturbance and compaction.

The effects of growing space loss may be evaluated by considering the overall pattern of roads, etc., relative to feasible silvicultural systems and yarding methods.

C. Biological Resources

Biological assessment areas will vary with the species being evaluated and its habitat. Factors to consider in the evaluation of cumulative biological impacts include:

1. Any known rare, threatened, or endangered species or sensitive species (as described in the Forest Practice Rules) that may be directly or indirectly affected by project activities.

Significant cumulative effects on listed species may be expected from the results of activities over time which combine to have a substantial effect on the species or on the habitat of the species.

2. Any significant, known wildlife or fisheries resource concerns within the immediate project area and the biological assessment area (e.g. loss of oaks creating forage problems for a local deer herd, species requiring special elements, sensitive species, and significant natural areas).

Significant cumulative effects may be expected where there is a substantial reduction in required habitat or the project will result in substantial interference with the movement of resident or migratory species.

The significance of cumulative impacts on non-listed species viability should be determined relative to the benefits to other non-listed species. For example, the manipulation of habitat results in conditions which discourage the presence of some species while encouraging the presence of others.

3. The aquatic and near-water habitat conditions on the THP and immediate surrounding area. Habitat conditions of major concern are: Pools and riffles, Large woody material in the stream, Near-water vegetation.

CALIFORNIA FOREST PRACTICE RULES

Much of the information needed to evaluate these factors is described in the preceding Watershed Resources section. A general discussion of their importance is given below:

a. Pools and Riffles. Pools and riffles affect overall habitat quality and fish community structure. Streams with little structural complexity offer poor habitat for fish communities as a whole, even though the channel may be stable. Structural complexity is often lower in streams with low gradients, and filling of pools can reduce stream productivity.

b. Large Woody Material. Large woody debris in the stream plays an important role in creating and maintaining habitat through the formation of pools. These pools comprise important feeding locations that provide maximum exposure to drifting food organisms in relatively quiet water. Removal of woody debris can reduce frequency and quality of pools.

c. Near-Water Vegetation. Near-water vegetation provides many habitat benefits, including: shade, nutrients, vertical diversity, migration corridors, nesting, roosting, and escape. Recruitment of large woody material is also an important element in maintaining habitat quality.

4. The biological habitat condition of the THP and immediate surrounding area. Significant factors to consider are:

- ◇ Snags/den trees
- ◇ Downed, large woody debris
- ◇ Multistory canopy
- ◇ Road density
- ◇ Hardwood cover
- ◇ Late seral (mature) forest characteristics.
- ◇ Late seral habitat continuity

The following general guidelines may be used when evaluating biological habitat. The factors described are general and may not be appropriate for all situations. The THP preparer must also be alert to the need to consider factors which are not listed below. Each set of ground conditions are unique and the analysis conducted must reflect those conditions.

a. Snags/Den/Nest Trees: Snags, den trees, nest trees and their recruitment are required elements in the overall habitat needs of more than 160 wildlife species. Many of these species play a vital role in maintaining the overall health of timberlands. Snags of greatest value are >16" DBH and 20 ft. in height. The degree of snag recruitment over time should be considered. Den trees are partially live trees with elements of decay which provide wildlife habitat. Nest trees have importance to birds classified as a sensitive species.

b. Downed large, woody debris: Large downed logs (particularly conifers) in the upland and near-water environment in all stages of decomposition provide an important habitat for many wildlife species. Large woody debris of greatest value consists of downed logs >16" diameter at the large end and >20 feet in length.

c. Multistory canopy: Upland multistoried canopies have a marked influence on the diversity and density of wildlife species utilizing the area. More productive timberland is generally of greater value and timber site capability should be considered as a factor in an assessment. The amount of upland multistoried canopy may be evaluated by estimating the percent of the stand composed of two or more tree layers on an average per acre basis.

Near-water multistoried canopies in riparian zones that include conifer and hardwood tree species provide an important element of structural diversity to the habitat requirements of wildlife. Near-water multistoried canopy may be evaluated by estimating the percentage of ground covered by one or more vegetative canopy strata, with more emphasis placed on shrub species along Class III and IV streams (14 CCR 916.5, 936.5, or 956.5).

d. Road Density: Frequently traveled permanent and secondary roads have a significant influence on wildlife use of otherwise suitable habitat. Large declines in deer and bear use of areas adjacent to open roads are frequently noted. Road density influence on large mammal habitat may be evaluated by estimating the miles of open permanent and temporary roads, on a per-section basis, that receive some level of maintenance and are open to the public. This assessment should also account for the effects of vegetation screening and the relative importance of an area to wildlife on a seasonal basis (e.g. winter range).

CALIFORNIA FOREST PRACTICE RULES

e. Hardwood Cover: Hardwoods provide an important element of habitat diversity in the coniferous forest and are utilized as a source of food and/or cover by a large proportion of the state's bird and mammal species. Productivity of deer and other species has been directly related to mast crops. Hardwood cover can be estimated using the basal area per acre provided by hardwoods of all species.

f. Late Seral (Mature) Forest Characteristics: Determination of the presence or absence of mature and over-mature forest stands and their structural characteristics provides a basis from which to begin an assessment of the influence of management on associated wildlife. These characteristics include large trees as part of a multilayered canopy and the presence of large numbers of snags and downed logs that contribute to an increased level of stand decadence. Late seral stage forest amount may be evaluated by estimating the percentage of the land base within the project and the biological assessment area occupied by areas conforming to the following definitions:

Forests not previously harvested should be at least 80 acres in size to maintain the effects of edge. This acreage is variable based on the degree of similarity in surrounding areas. The area should include a multi-layered canopy, two or more tree species with several large coniferous trees per acre (smaller subdominant trees may be either conifers or hardwoods), large conifer snags, and an abundance of large woody debris.

Previously harvested forests are in many possible stages of succession and may include remnant patches of late seral stage forest which generally conform to the definition of unharvested forests but do not meet the acreage criteria.

g. Late Seral Habitat Continuity: Projects containing areas meeting the definitions for late seral stage characteristics must be evaluated for late seral habitat continuity. The fragmentation and resultant isolation of late seral habitat types is one of the most significant factors influencing the sustainability of wildlife populations not adapted to edge environments.

This fragmentation may be evaluated by estimating the amount of the on-site project and the biological assessment area occupied by late seral stands greater than 80 acres in size (considering the mitigating influence of adjacent and similar habitat, if applicable) and less than one mile apart or connected by a corridor of similar habitat.

h. Special Habitat Elements: The loss of a key habitat element may have a profound effect on a species even though the habitat is otherwise suitable. Each species may have several key limiting factors to consider. For example, a special need for some large raptors is large decadent trees/snags with broken tops or other features. Deer may have habitat with adequate food and cover to support a healthy population size and composition but dependent on a few critical meadows suitable for fawning success. These and other key elements may need special protection.

D. RECREATIONAL RESOURCES: The recreational assessment area is generally the area that includes the logging area plus 300 feet.

To assess recreational cumulative impacts:

1. Identify the recreational activities involving significant numbers of people in and within 300 ft. of logging area (e.g., fishing, hunting, hiking, picnicking, camping).

2. Identify any recreational Special Treatment Areas described in the Board rules on the plan area or contiguous to the area.

E. VISUAL RESOURCES: The visual assessment area is generally the logging area that is readily visible to significant numbers of people who are no further than three miles from the timber operation. To assess visual cumulative effects:

1. Identify any Special Treatment Areas designated as such by the Board because of their visual values.

2. Determine how far the proposed timber operation is from the nearest point that significant numbers of people can view the timber operation. At distances of greater than 3 miles from viewing points activities are not easily discernible and will be less significant.

3. Identify the manner in which the public identified in 1 and 2 above will view the proposed timber operation (from a vehicle on a public road, from a stationary public viewing point or from a pedestrian pathway).

F. VEHICULAR TRAFFIC IMPACTS: The traffic assessment area involves the first roads not part of the logging area on which logging traffic must travel. To assess traffic cumulative effects:

1. Identify whether any publicly owned roads will be used for the transport of wood products.

CALIFORNIA FOREST PRACTICE RULES

2. Identify any public roads that have not been used recently for the transport of wood products and will be used to transport wood products from the proposed timber harvest.
3. Identify any public roads that have existing traffic or maintenance problems.
4. Identify how the logging vehicles used in the timber operation will change the amount of traffic on public roads, especially during heavy traffic conditions.

Article 3 Silvicultural Methods

913, 933, 953 Silvicultural Objectives [All Districts]

The objectives of this article are to describe standard silvicultural systems and to provide for alternatives that when applied shall meet the objectives of the FPA (PRC 4512 and 4513). The RPF shall select systems and alternatives which achieve maximum sustained production of high quality timber products. The THP shall designate one or a combination of regeneration methods, prescriptions or intermediate treatments described by this article. If a method, prescription or treatment not defined in the rules (see 14 CCR 895.1), is to be used an alternative prescription shall be included in the plan. The assessment of maximum sustained production of high quality timber products is based on:

- (a) Regeneration methods, intermediate treatments and prescriptions described in the rules which establish standards. These methods, treatments, prescriptions, and standards shall not be utilized to permit harvesting of growing stock in a manner that will significantly delay reaching or maintaining maximum sustained production.
- (b) Published yield tables or other tools which can be validated and which serve as a point of reference for evaluating and selecting silvicultural systems and their implementation.
- (c) The Sustained Yield Plan: The SYP establishes the flow of forest products from managed timberlands, and shall demonstrate the achievement of maximum sustained production.
- (d) An assessment of maximum sustained production of high quality timber products is not required for a harvest designated as, and meeting the definition of fuelbreak/defensible space under 14 CCR 913.4 [933.4, 953.4] Special Prescriptions. Because these lands are designated as defensible space areas, the wood production potential of these lands is compatible with the lowest site classifications and they shall be considered site IV timberland for stocking purposes.

913.1, 933.1, 953.1 Regeneration Methods Used in Evenaged Management [All Districts; except variances in (a)(4)(A) and (d)(3) Shelterwood Removal Step]

The following types of regeneration methods are designed to replace a harvestable stand with well spaced growing trees of commercial species. Evenaged management systems shall be applied with the limitations described by this rule:

- (a) Timber stands harvested under an evenaged regeneration method shall meet the following standards:
 - (1) Where a regeneration step harvest of evenaged management will occur on stands younger than 50 years of age for Class I lands, 60 years of age for Class II and III lands, or 80 years of age for Class IV and V lands, or equivalent age of trees, based on height as determined according to the appropriate site class, the RPF preparing the THP or SYP must demonstrate how the proposed harvest will achieve MSP pursuant to Section 913.11(a) or (b) provided, however, that the Director may grant an exemption from this section based upon hardship.
 - (2) The regeneration harvest of evenaged management shall be limited to 20 acres for tractor yarding. Aerial or cable yarding may be 30 acres. Tractor yarding may be increased to 30 acres where the EHR is low and the slopes are < 30%. The RPF may propose increasing these acreage limits to a maximum of 40 acres, and the Director may agree where measures contained in the THP provide substantial evidence that the increased acreage limit does any one of the following:
 - (A) by using additional on-site mitigation measures, reduces the overall detrimental effects of erosion thereby providing better protection of soil, water, fish and/or wildlife resources; or
 - (B) provides for the inclusion of "long corners"; or
 - (C) create a more natural logging unit by taking maximum advantage of the topography; or
 - (D) will increase long-term sustained yield; or
 - (E) provide feasible off-site mitigation measures that can be incorporated in the plan to restore or enhance previously impacted resource areas or other environmental enhancements that will result

CALIFORNIA FOREST PRACTICE RULES

in demonstrable net environmental benefits within the planning watershed. These measures may include, but are not limited to, watercourse restoration, soil stabilization, road surface stabilization, road outcropping, road abandonment, road reconstruction, enhancement of wildlife habitats and vegetation management. To qualify for an exemption the plan submitter is not required to demonstrate that other feasible options are not available.

(3) Evenaged regeneration units within an ownership shall be separated by a logical logging unit that is at least as large as the area being harvested or 20 acres, whichever is less, and shall be separated by at least 300 ft. in all directions.

(4) Within ownership boundaries, no logical logging unit contiguous to an evenaged management unit may be harvested using an evenaged regeneration method unless the following are met:

(A) [Coast] The prior evenaged regeneration unit has an approved report of stocking, and the dominant and codominant trees average at least five years of age or average at least five ft. tall and three years of age from the time of establishment on the site, either by the planting or by natural regeneration. If these standards are to be met with trees that were present at the time of the harvest, there shall be an interval of not less than five years following the completion of operations before adjacent evenaged management may occur.

(A) [Northern and Southern] The prior evenaged regeneration unit has an approved report of stocking, and the dominant and codominant trees average at least five feet tall, or at least five years of age from the time of establishment on the site, either by the planting or by natural regeneration. If these standards are to be met with trees that were present at the time of the harvest, there shall be an interval of not less than five years following the completion of operations before adjacent evenaged management may occur.

(5) Except for the clearcut method, all trees to be harvested or all trees to be retained shall be marked by, or under the supervision of, an RPF prior to felling operations. A sample area shall be marked prior to a preharvest inspection. The sample area shall include at least 10% of the harvest area up to a maximum of 20 acres per stand type, and must be representative of the range of conditions present in the area. The marking requirement may be waived by the Director if the trees to be harvested are easily distinguished from the trees to be retained, when explained and justified by the RPF in the plan.

(6) Special consideration for aesthetic enjoyment shall be given to selection of silvicultural treatments and timber operations within 200 feet of the edge of the traveled surface of any permanent road maintained by the County, or the State.

(7) Special consideration for aesthetic enjoyment and protection of adjacent stand vigor shall be given to the selection of silvicultural methods and timber operations within 200 feet of adjacent non-federal lands not zoned TPZ.

(b) **Clearcutting** The clearcutting regeneration method involves the removal of a stand in one harvest. Regeneration after harvesting shall be obtained by direct seeding, planting, sprouting, or by natural seed fall. When practical, clearcuts shall be irregularly shaped and variable in size in order to mimic natural patterns and features found in landscapes. Site preparation and slash disposal measures, if necessary for successful regeneration, shall be described in the plan.

(c) **Seed Tree** The seed tree regeneration method involves the removal of a stand in one harvest except for well distributed seed trees of desired species which are left singly or in groups to restock the harvested area. The seed step is utilized to promote natural reproduction from seed and to initiate the establishment of an evenaged stand. The removal step may be utilized to remove the seed trees after a fully stocked stand of reproduction has become established.

(1) **Seed Tree Seed Step:** The seed tree seed step is the regeneration step and shall meet the following requirements:

(A) Retention of at least 8 seed trees per acre which are 18 inches dbh or greater. Each seed tree 24 inches dbh or greater shall be equivalent to 2 seed trees less than 24 inches dbh. The seed trees must be of full crown, capable of seed production and representative of the best phenotypes available in the preharvest stand.

(B) No point within the logged area shall be more than 150 feet from a seed tree.

CALIFORNIA FOREST PRACTICE RULES

(C) Seed tree species and site preparation measures shall be specified in the plan by the RPF.

(D) Seed trees shall be marked by or under the supervision of an RPF prior to felling operations.

(E) If natural regeneration is inadequate within two years after the first August following completion of timber operations, seed trees may be harvested and artificial regeneration shall be used to meet the requirements of 912.7(b)(1) [932.7(b)(1), 952.7(b)(1)].

(F) In the absence of a Sustained Yield Plan, to maintain and improve tree species diversity, genetic material and seed production, trees of each native commercial species where present at the time of harvest shall be retained after harvest. These leave trees shall be representative of the best phenotypes available in the preharvest stand. The RPF may propose and the Director may agree to a species specific plan in the THP which protects existing regeneration or provides for regeneration in-lieu of retaining trees.

(2) Seed Tree Removal Step Not more than 15 predominant trees per acre may be removed in the seed tree removal step. Not more than 50 sq. ft. of basal area of predominant trees per acre may be removed in the seed tree removal step. The seed tree removal step may be utilized when the regeneration present exceeds the minimum stocking requirements set forth in 14 CCR 912.7(b)(1) [932.7(b)(1), 952.7(b)(1)]. Regeneration shall not be harvested under the seed tree method unless the trees are dead, dying or diseased or substantially damaged during timber operations. The minimum stocking standards of 14 CCR 912.7(b)(1) [932.7(b)(1), 952.7(b)(1)] shall be met immediately upon completion of operations. The seed tree removal step shall only be used once in the life of the stand unless otherwise agreed to by the Director.

If the extent and intensity of the soil and vegetation disturbance caused by the harvest is similar to what would have been caused by a clearcut, the size limitations, separation (spacing) by logical logging unit requirements, and yarding equipment limitations of 14 CCR 913.1(a) [933.1(a), 953.1(a)] are applicable.

(d) Shelterwood The shelterwood regeneration method reproduces a stand via a series of harvests (preparatory, seed, and removal). The preparatory step is utilized to improve the crown development, seed production capacity and wind firmness of designated seed trees. The seed step is utilized to promote natural reproduction from seed. The removal step is utilized when a fully stocked stand of reproduction has become established, and this step includes the removal of the protective overstory trees. The shelterwood regeneration method is normally utilized when some shade canopy is considered desirable for the establishment of regeneration.

(1) Shelterwood Preparatory Step The shelterwood preparatory step shall meet the following minimum standards:

(A) At least 16 seed trees per acre which are 18 inches dbh or greater shall be retained. Each seed tree 24 inches dbh or greater shall be equivalent to 2 seed trees less than 24 inches dbh. The seed trees must be of full crown, capable of seed production and representative of the best phenotypes available in the preharvest stand.

(B) No point within the logged area shall be more than 100 ft. from a seed tree.

(C) Seed tree species shall be specified in the plan by the RPF.

(D) At least 125 sq. ft. of basal area per acre on Site I lands, and 75 sq. ft. of basal area per acre on Site II and III lands and 50 sq. ft. of basal area per acre on site IV and V lands shall be retained.

(E) The minimum stocking standards of 912.7(b)(1) [932.7(b)(1), 952.7(b)(1)] shall be met immediately upon completion of operations. Within six months following completion of work described in the plan, a report of stocking shall be filed as stated in PRC 4587.

(2) Shelterwood Seed Step The shelterwood seed step is the regeneration step and shall meet the following standards:

(A) At least 16 seed trees per acre which are 18 inches dbh or greater shall be retained. Each seed tree 24 inches dbh or greater shall be equivalent to 2 seed trees less than 24 inches dbh. The seed trees must be of full crown, capable of seed production and representative of the best phenotypes available in the preharvest stand.

(B) No point within the logged area shall be more than 100 ft. from a seed tree.

(C) Seed tree species and site preparation measures shall be specified in the plan by the RPF.

CALIFORNIA FOREST PRACTICE RULES

(D) Seed trees shall be marked by or under the supervision of an RPF prior to felling operations.

(E) If natural regeneration is inadequate within two years after the first August following completion of timber operations, seed trees may be harvested and artificial regeneration shall be used to meet the requirements of 912.7(b)(1), [932.7(b)(1), 952.7(b)(1)].

(F) In the absence of a Sustained Yield Plan, to maintain and improve tree species diversity, genetic material and seed production, trees of each native commercial species where present at the time of harvest shall be retained after harvest. These leave trees shall be representative of the best phenotypes available in the preharvest stand. The RPF may propose and the Director may agree to a species specific plan in the THP which protects existing regeneration or provides for regeneration in-lieu of retaining trees.

(3) **Shelterwood Removal Step [Coast only]** The shelterwood removal step may be utilized when the regeneration present exceeds the minimum stocking requirements set forth in 14 CCR 912.7(b)(1). Unless otherwise agreed to by the Director, the Shelterwood removal shall only be used once in the life of the stand. Regeneration shall not be harvested during the shelterwood removal step unless the trees are dead, dying or diseased or substantially damaged by timber operations. The minimum stocking standards of 912.7(b)(1) shall be met immediately upon completion of operations. The size limitations, and separation (spacing) by logical logging unit requirements, of 14 CCR 913.1(a) are applicable unless the post-harvest stand, regardless of average diameter, meets the stocking standards of 14 CCR 913.3(a)(1)(A) or (B)]. Not more than 32 predominant trees per acre may be removed in the shelterwood removal step. Not more than 100 square feet of basal area of predominant trees per acre may be removed in the shelterwood removal step.

(3) **Shelterwood Removal Step [Northern and Southern]** The shelterwood removal step may be utilized when the regeneration present exceeds the minimum stocking requirements set forth in 14 CCR 932.7(b)(1) [952.7(b)(1)]. Unless otherwise agreed to by the Director, the Shelterwood removal shall only be used once in the life of the stand. Regeneration shall not be harvested during the shelterwood removal step unless the trees are dead, dying or diseased or substantially damaged by timber operations. The minimum stocking standards of 932.7(b)(1) [952.7(b)(1)] shall be met immediately upon completion of operations.

If the extent and intensity of the ground disturbance caused by the harvest is essentially the same as would have been caused by a clearcut or will cause adverse cumulative effects on wildlife as determined by the RPF or Director, the size limitations, and separation (spacing) by logical logging unit requirements of 14 CCR 933.1(a) [953.1(a)] are applicable unless the post harvest stand, regardless of average diameter, meets area stocking standards of 14 CCR 933.3(a)(1)(A) or (B) [953.3(a)(1)(A) or (B)].

913.2, 933.2, 953.2 Regeneration Methods Used in Unevenaged Management [All Districts, Note variations by District]

Unevenaged management is utilized to establish and maintain an unevenaged stand structure. Unevenaged management attributes include the establishment and/or maintenance of a multi-aged, balanced stand structure, promotion of growth on leave trees throughout a broad range of diameter classes, and encouragement of natural reproduction.

(a) **Selection** Under the selection regeneration method, the trees are removed individually or in small groups sized from .25 acres to 2.5 acres.

(1) Trees to be harvested or trees to be retained shall be marked by or under the supervision of the RPF prior to felling operations. When openings greater than .25 acres will be created, the boundaries of the small group(s) may be designated in lieu of marking individual trees within the small group areas. A sample area must be marked prior to a preharvest inspection for evaluation. The sample area shall include at least 10% of the harvest area up to a maximum of 20 acres per stand type which is representative of the range of conditions present in the area.

(2) Post harvest stand stocking levels shall be stated in the THP. The level of residual stocking shall be consistent with maximum sustained production of high quality timber products. In no case shall stocking be reduced below the following standards:

(A) Selection System.

1. On Site I lands at least 125 [Coast], [100 Northern & Southern] square feet per acre of basal area shall be retained.

CALIFORNIA FOREST PRACTICE RULES

retained.

2. On Site II and III lands at least 75 square feet per acre of basal area shall be

retained.

3. On Site IV and V lands at least 50 square feet per acre of basal area shall be

4. Unless the plan submitter demonstrates how the proposed harvest will achieve MSP pursuant to Section 913.11 (a) or (b), the residual stand shall contain sufficient trees to meet at least the number, size, and phenotypic quality of tree requirement specified under the seed tree method.

(B) Group Selection.

1. At least 80% of the stocked plots must meet the Basal Area stocking standards of 913.2(a)(2)(A), [933.2(a)(2)(A); 953.2(a)(2)(A)].

2. Not more than 20% of the stocked plots may meet stocking standards utilizing the 300 point count standard with trees that are at least 10 (ten) years old.

3. An RPF or supervised designee may offset up to 8 plots per 40 plots where those plot centers are initially placed within small group clearings created during the current harvest. Unless substantially damaged by fire, the RPF or supervised designee shall not exclude small group clearings created by previous timber harvesting from the stocking survey.

4. Unless the plan submitter demonstrates how the proposed harvest will achieve MSP pursuant to Section 913.11(a) or (b), the residual stand shall contain sufficient trees to meet at least the number, size, and phenotypic quality of tree requirements specified under the seed tree method.

- (3) Within any THP, small group clearings under the selection method shall be separated by a logical logging area.

- (4) Following completion of timber operations (including site preparation) not more than 20 percent of the THP area harvested by this method shall be covered by small group clearings.

- (5) Exceptions to stocking standards in 913.2(a)(2), [933.2(a)(2), 953.2(a)(2)] above may be granted only when proposed by the RPF and explained and justified in the plan, but in no case will the exceptions be less than specified in 14 CCR 912.7 (b)(2), [932.7(b)(2), 952.7(b)(2)]. Exceptions may only be granted when the RPF clearly demonstrates that the existing stand will grow substantially less than both the potential site productive capacity and the proposed post harvest stand.

(b) Transition. The transition method may be used to develop an unevenaged stand from a stand that currently has an unbalanced irregular or evenaged structure. The transition method involves the removal of trees individually or in small groups from irregular or evenaged stands to create a balanced stand structure and to obtain natural reproduction.

- (1) This method is used no more than twice to increase stocking and improve the balance of age classes so as to allow the residual stand to be managed by the selection or group selection method.

- (2) Stands suitable for the transition method contain adequate quantity and quality of seed producing trees to provide maximum regeneration for new age classes. Stands suitable for this method have no more than 25 sq. ft. of basal area greater than the selection basal area standards. Area for determination of preharvest stocking levels shall be no greater than 20 acres in size if such a breakdown will change the stocking levels of individual areas.

- (3) Trees to be harvested or trees to be retained shall be marked by or under the supervision of an RPF before felling operations. A sample area must be marked before preharvest inspection for evaluation. The sample area shall include at least 10% of the harvest area up to a maximum of 20 acres per stand type which is representative of the range of conditions present.

- (4) Immediately following the completion of timber operations on the first use of this method, the minimum basal area standards in 14 CCR 912.7(b)(2), [932.7(b)(2), 952.7(b)(2)] shall be met.

- (5) Unless the plan submitter demonstrates how the proposed harvest will achieve MSP pursuant to Section 913.11(a) or (b), the residual stand shall contain sufficient trees to meet at least the number, size, and phenotypic quality of the leave tree requirements specified under the seed tree method.

- (6) Following completion of timber operations (including site preparation) not more than 20 percent of the THP area harvested by this method shall be covered by small group clearings.

- (7) No sooner than ten years following completion of the first entry with this method a second harvest using this method may be conducted.

(A) The standards of (1), (2), (3), (4), (5) and (6) above shall apply to the second entry.

CALIFORNIA FOREST PRACTICE RULES

(B) The THP submitter must provide the Director sufficient information such as growth and stand description to demonstrate that the standards of the selection method will be met for subsequent selection harvests.

(c) Within six months following completion of timber operations conducted pursuant to the selection and transition methods as described in the plan, a report of stocking shall be filed as stated in PRC Section 4587.

(d) In the absence of a Sustained Yield Plan, to maintain and improve tree species diversity, genetic material, and seed production, trees of each native commercial species where present at the time of harvest shall be retained after harvest. These leave trees shall be representative of the best phenotypes available in the preharvest stand. The RPF may propose and the Director may agree to a species specific plan in the THP which protects existing regeneration or provides for regeneration in-lieu of retaining trees.

913.3, 933.3, 953.3 Intermediate Treatments

(a) **Commercial thinning.** Commercial thinning is the removal of trees in a young-growth stand to maintain or increase average stand diameter of the residual crop trees, promote timber growth, and/or improve forest health. The residual stand shall consist primarily of healthy and vigorous dominant and codominant trees from the preharvest stand.

(1) Post harvest stand stocking levels shall be stated in the THP. The level of residual stocking shall be consistent with maximum sustained production of high quality timber products. Generally stands will develop stand structures with considerably higher levels of basal area than provided in these minimum standards as stand age increases. In no case shall stocking be reduced below the following standards:

(A) Where the preharvest dominant and codominant crown canopy is occupied primarily by trees greater than 14 in. DBH:

[Coast]:

1. On Site I lands at least 125 sq. ft. per acre of basal area shall be left.
2. On Site II and III lands at least 100 sq. ft. per acre of basal area shall be left.
3. On Site IV lands at least 75 sq. ft. per acre of basal area shall be left.
4. On Site V lands, at least 50 sq. ft. per acre of basal area shall be left.

[Northern, Southern]:

1. On Site I mixed conifer lands at least 125 sq. ft. per acre of basal area shall be left, and on Site I land where greater than 50% of the basal area is pine, at least 100 sq. ft. per acre of basal area shall be left.
2. On Site II mixed conifer lands at least 100 sq.ft. per acre of basal area shall be left, and on Site II lands where greater than 50% of the basal area is pine, at least 75 sq. ft. per acre of basal area shall be left.
3. On Site III mixed conifer lands at least 75 sq. ft. per acre of basal area shall be left, and on Site III lands where greater than 50% of the basal area is pine, at least 75 sq. ft. per acre of basal area shall be left.
4. On Site IV and V mixed conifer lands, at least 50 sq. ft. per acre of basal area shall be left, and on Site IV and V lands where greater than 50% of the basal area is pine at least 50 sq. ft. per acre of basal area shall be left.

(B) Where the preharvest dominant and codominant crown canopy is occupied primarily by trees less than 14 in. DBH, a minimum of 100 trees per acre over 4 in. DBH shall be retained for site I, II and III. For site IV and V - 75 trees per acre over 4 in. dbh shall be retained.

(2) Exceptions to these stocking standards may be proposed by the RPF when explained and justified in the plan, but in no case will the standards be below those specified in 14 CCR 912.7(b)(2) [932.7(b)(2), 952.7(b)(2)].

(3) For stands harvested in compliance with 14 CCR 913.3(a)(1)(A) [933.3(a)(1)(A), 953.3(a)(1)(A)] the trees to be harvested or the trees to be retained shall be marked by or under the supervision of an RPF prior to felling operations. For all thinning proposals, a sample area must be marked prior to a preharvest inspection for evaluation. The sample area shall include at least 10% of the thinning area up to a maximum of 20 acres per stand type which is representative of the range of conditions present in the area. The Director may waive the marking requirements for the remainder of the THP area when explained and justified in the THP.

CALIFORNIA FOREST PRACTICE RULES

(4) Within six months following completion of timber operations as described in the plan, a report of stocking shall be filed as stated in PRC Section 4587.

(b) Sanitation-Salvage. Sanitation is the removal of insect attacked or diseased trees in order to maintain or improve the health of the stand. Salvage is the removal of only those trees which are dead, dying, or deteriorating, because of damage from fire, wind, insects, disease, flood, or other injurious agent. Salvage provides for the economic recovery of trees prior to a total loss of their wood product value. Sanitation and salvage may be combined into a single operation. The following requirements apply to the use of the sanitation-salvage treatment:

(1) The RPF shall estimate in the THP the expected level of stocking to be retained upon completion of operations.

(2) Immediately upon completion of operations, the area shall meet the stocking standards of 14 CCR 912.7(b) [932.7(b), 952.7(b)] unless explained and justified in the plan. If stocking is to be met immediately following completion of operations, a report of stocking shall be filed within 6 months of completion. If this standard cannot be met, the area must be planted during the first planting season following completion of operations and the minimum stocking standards of 14 CCR 912.7(b)(1) [932.7(b)(1), 952.7(b)(1)] must be met within 5 years following completion of operations.

(3) Trees to be harvested or trees to be retained shall be marked by or under the supervision of an RPF prior to felling operations. When openings greater than .25 acres will be created, the boundaries of the small group(s) may be designated in lieu of marking individual trees within the small group areas. A sample area must be marked prior to a preharvest inspection for evaluation. The sample area shall include at least 10% of the area, up to a maximum of 20 acres per stand type, whichever is less, which is representative of the range of conditions present in the area. The Director may waive the marking requirement for the remainder of the THP area when explained and justified in the THP.

913.4, 933.4, 953.4 Special Prescriptions

The following special harvesting methods are appropriate under certain conditions:

(a) Special Treatment Area Prescriptions. Special consideration in Special Treatment Areas shall be given to selection of a regeneration method or intermediate treatment compatible with the objectives for which the special area was established. Such areas shall be identified in the plan. To assure the integrity of legally designated historical and archaeological sites and legally designated ecological reserves, and that the objectives of the special treatment areas are met, the RPF and the Director may agree, after on-the-ground inspection, if requested by either party, on specific silvicultural and logging practices to protect such areas. The Director shall notify affected agencies or groups with expertise in the resource involved in the special treatment area of any such areas located during the THP review process.

(b) Rehabilitation of Understocked Area Prescription. For the purposes of restoring and enhancing the productivity of commercial timberlands which do not meet the stocking standards defined in 14 CCR 912.7 [932.7, 952.7] prior to any timber operations on such lands, an area may be harvested provided it is restocked in accordance with Subsections (1) or (2). To facilitate restocking, a regeneration plan must be included in the THP. The regeneration plan shall include site preparation, method of regeneration, and other information appropriate to evaluate the plan.

(1) If the area meets the standards of 14 CCR 912.7 [932.7, 952.7] within five years of completion of timber operations, the area shall be considered acceptably stocked, or shall be considered acceptably stocked if it contains at least 10 planted countable trees for each tree harvested on sites I, II, and III, and 5 planted countable trees for each tree harvested on site IV and V.

(2) On understocked timberlands where no countable conifer trees are to be harvested and the broadleaf species are not designated for management, the area shall be planted to equal or exceed the stocking standards of 14 CCR 912.7(b)(1) [932.7(b)(1), 952.7(b)(1)] and shall be considered acceptably stocked if within five years of completion of timber operations it contains at least an average point count of 150 of Group A species on all site classifications.

(c) Fuelbreak/Defensible Space. Where some trees and other vegetation and fuels are removed to create a shaded fuel break or defensible space in an area to reduce the potential for wildfires and the damage they might cause. Minimum stocking standards within the timber operating area shall be met immediately after harvest and shall be those found in 14 CCR 912.7 [932.7, 952.7]. The RPF shall describe in the plan specific vegetation and fuels treatment, including timing, to reduce fuels to meet the objectives of the Community

CALIFORNIA FOREST PRACTICE RULES

Fuelbreak area.

913.5, 933.5, 953.5 Stocking Status

Under any regeneration method where artificial regeneration is specified in the plan to restock the logged area, a preliminary report on the degree of stocking shall be submitted to the Director annually, between October 1 and December 31, beginning two years following completion of logging by the timber owner or his/her agent until the stocking standard of 14 CCR 912.7 [932.7, 952.7] is met or exceeded or as otherwise required. This report shall indicate the degree of stocking achieved and any additional measures that will be taken to stock the logged area.

913.6, 933.6, 953.6 Alternative Prescriptions [All Districts]

(a) An alternative prescription shall be included in a THP when, in the judgment of the RPF, an alternative regeneration method or intermediate treatment offers a more effective or more feasible way of achieving the objectives of Section 913 [933, 953] than any of the standard silvicultural methods provided in this Article.

(b) An alternative prescription, as defined in 14 CCR 895.1, shall normally contain at least the following information:

(1) A description of the stand before timber operations, including:

(A) The RPF's professional judgment of the species composition of the stand before harvest.

(B) The RPF's professional judgment of the current stocking on the area expressed in basal area or a combination of basal area and point count.

(C) The RPF's estimate of the basal area per acre to be removed from the stand during harvest.

(2) A description of stand management constraints such as animal, insect, disease, or other natural damage, competing vegetation, harsh site conditions, or other problems which may affect stand management.

(3) A statement of which silvicultural method in the current District rules is most nearly appropriate or feasible and an explanation of why it is not appropriate or feasible.

(4) An explanation of how the proposed alternative prescription will differ from the most nearly feasible method in terms of securing regeneration; protection of soil, water quality, wildlife habitat, and visual appearance; and in terms of fire, insect and disease protection.

(5) A description of the stand expected after completion of timber operations, including the following:

(A) The management objective under which the post-harvest stand is to be managed (evenaged, unevenaged, or neither);

(B) The desired tree species composition of the post-harvest stand and the RPF's judgment as to the remaining stocking after harvest expressed as basal area or a combination of basal area and point count.

(6) The treatment of the stand to be used in harvesting including:

(A) The guidelines to be used in determining which trees are to be harvested or left;

(B) The type of field designation to be followed, such as marking, sample marking of at least 20 percent of the trees to be harvested or left, professional supervision of fallers or other methods; and

(C) The site preparation and regeneration method and timetable to be used for restocking.

(c) If an alternative prescription will have the practical on-the-ground effect of a clearcut, regardless of name or description, then the acreage limitations, and requirement for separation by a typical logging unit, yarding equipment limitations, exceptions, and stocking requirements for the clearcut regeneration method shall apply.

(d) All trees to be harvested or all trees to be retained shall be marked by, or under the supervision of, an RPF prior to harvest. A sample area must be marked prior to the preharvest inspection for evaluation. The sample area shall include at least 10% of the harvest area to a maximum of 20 acres per stand type which is representative of the range of conditions present in the area. The Director may waive the requirements for the remainder of the area when explained and justified by the RPF in the THP.

(e) The Director shall approve the alternative if in his judgment it complies with 14 CCR 898 and if, considering the entire area to which the alternative is to be applied, it would:

CALIFORNIA FOREST PRACTICE RULES

(1) When compared with the standard method identified in subsection (b)(3) above have an effect equal to or more favorable than such standard method would achieve in the areas of values relating to soil, the quality and beneficial uses of water, wildlife and fisheries,

(2) Not create a significant adverse change in range and forage, and recreation and aesthetic values; and

(3) Not reduce the after harvest stocking standards or evenaged prescription limitation below the most closely associated standard, unless the RPF demonstrates that either:

(A) The harvest will result in stand conditions that will increase long term sustained yield as compared to the long term sustained yield achieved by utilizing the stocking standards of the method identified in subsection (b)(3); or

(B) The yield over 20 years of a "No Harvest" alternative would be less than the yield over 20 years of the proposed alternative.

(4) Not lead to the direct or indirect conversion of the timberland to other land uses not associated with timber growing and harvesting and compatible uses unless a timberland conversion permit is approved before submission of the THP; and

(5) Not result in violations of any of the other standards in the rules of the Board.

913.7, 933.7 Exceptions [Coast, Northern]

The requirements of this article shall not prohibit the timber operator from cutting or removing trees for the purposes of:

(a) Clearing rights-of-way, log landings, campsites, or firebreaks necessary for the conduct of timber operations.

(b) The harvesting of Christmas trees and construction of a public fire protection agency fuel break is also permitted.

953.7 Riparian Vegetation [Southern]

All noncommercial riparian vegetation found along streams and lakes and within meadows and wet areas shall be retained and protected insofar as practical.

953.8 Exceptions [Southern]

The requirements of this article shall not prohibit the operator from cutting or removing trees for purposes of clearing rights-of-way, log landings, campsites, or firebreaks necessary for the conduct of timber operations. The harvesting of Christmas trees and construction of a public fire protection agency fuelbreak is also permitted.

913.8 Special Harvesting Methods for Southern Subdistrict [Coast]

Only the following regeneration methods and stocking requirements shall apply in the Southern Subdistrict of the Coast Forest District. Timber operations shall be conducted in accordance with subsections (a), (b), (c), or (d) below. If the provisions of more than one subsection will be used within any individual timber operation or logging area, a line separating the areas to be cut under provisions of each shall be shown in the plan and clearly defined on the ground by paint or other means prior to filing the plan and so as to be readily identifiable during and after completion of logging.

(a) Leave uncut a well-distributed timber stand after timber operations have been completed on the logging area that is at least 40% by number of those trees 45.7 cm (18 in.) and more d.b.h. present prior to commencement of current timber operations and at least 50% by number of those trees over 30.5 cm (12 in.) d.b.h., but less than 45.7 cm (18 in.) d.b.h. Leave trees shall be thrifty coniferous trees which were dominant or codominant in crown class prior to timber harvesting or which have crowns typical of such dominant or codominant trees. They shall be free from significant damage caused by the timber operations. No conifer shall be cut which is more than 22.9 m (75 ft.) from a leave tree 30.5 cm (12 in.) d.b.h. or larger located within the logging area. Average top stump diameter, outside bark, shall be considered 2.5 cm (1 in.) greater than d.b.h. No area may be cut in excess of the leave tree standards of this rule in any 10 year period. Upon completion of timber operations one of the following stocking standards for coniferous trees shall be met:

CALIFORNIA FOREST PRACTICE RULES

(1) Basal Area. The average residual basal area, measured in stems 2.5 cm (1 in.) or larger in diameter at least 27.6 m sq./ha (120 sq. ft. per acre) on Site I lands, and at least 22.7 m sq./ha (100 sq. ft. per acre) on Site II lands, and 17.22 m sq./ha (75 sq. ft. per acre) on Site III lands, and 11.48 m sq. sq./ha (50 square feet per acre) on Sites IV and V lands.

(2) Countable Trees. The area contains a well-distributed stand of trees with an average of at least 1112 countable trees per ha (450 point count per acre) as determined by using the following countable tree equivalents:

(A) 1112 countable trees per ha (450 countable trees per acre) not more than 10.2 cm (4 in.) d.b.h.; each tree to count as one toward meeting stocking requirements.

(B) 371 countable trees per ha (150 countable trees per acre) over 10.2 cm (4 in.) d.b.h. and not more than 30.5 cm (12 in.) d.b.h.; each tree to count as 3 toward meeting stocking requirements.

(C) 185 countable trees per ha (75 countable trees per acre) over 30.5 cm (12 in.) d.b.h. and not more than 45.7 cm (18 in.) d.b.h.; each tree to count as 6 toward meeting stocking requirements.

(D) 124 countable trees per ha (50 countable trees per acre) over 45.7 cm (18 in.) d.b.h.; and not more than 61 cm (24 in.) d.b.h.; each tree to count as 9 toward meeting stocking requirements.

(E) 74 countable trees per ha (30 countable trees per acre) over 61 cm (24 in.) d.b.h.; each tree to count as 15 toward meeting stocking requirements.

(F) Redwood root crown sprouts over .3 m (1 ft.) in height will be counted using the average stump diameter .3 m (1 ft.) above average ground level of the original stump from which the redwood root crown sprouts originate counting 1 sprout for each .3 m (1 ft.) of stump diameter to a maximum of 6 per stump. Any countable redwood root crown sprout over .3 m (1 ft.) in height but less than 10.2 cm (4 in.) d.b.h. shall count as one toward meeting stocking requirements.

(b) An alternative regeneration method may be approved only if all of the following are met:

(1) The regeneration method described in subsection (a) above is not silviculturally appropriate or feasible in the professional judgment of the Director and the RPF who prepared the plan.

(2) Cutting methods prescribed under the provisions of this section must maintain a well-distributed tree crown cover of at least 50% of the pre-existing tree crown canopy. At no time shall the crown cover be reduced to a level where the productivity of the land is jeopardized or to a level which would create a threat to soil and/or water resources. Provided the required crown cover can be maintained, the removal of all trees in small groups not exceeding .202 ha (one-half acre) in size may be approved as part of the overall cutting prescription.

(3) The alternative method shall provide overall protection at least equal to that of the standard provided by subsection (a) for watershed, wildlife, soil and aesthetic resources considering the silvicultural method, conditions necessary for regeneration, tree growth rate, annual rainfall, summer temperature and length of dry season, critical problems of erodible soils, unstable areas, need for high water quality, increased fire potential and exposure to more intensive use.

(4) A plan agreed upon between the RPF and the Director is prepared which gives timber stand information concerning stocking levels, cutting goals, timber stand growth and future harvest timing expectations. The plan must also include information on site location and preparation for planting required under (6) below.

(5) The timber operator is responsible for carrying out timber operations as described in the plan. The plan submitter is responsible for retaining an RPF to provide professional advice to the timber operator and timberland owner on a continuing basis throughout the timber operations. The RPF or the designee of the RPF works closely with the timber operator to help assure compliance with the approved alternative prescription and the terms and specifications of the approved plan. The RPF or the designee of the RPF is present on the harvest area sufficient hours each week to know the operations' progress and advise the timber operator. The RPF informs the timber operator of potential environmental impacts and the mitigation measures to be taken to minimize such impacts. The timber operator shall sign the plan and major amendments thereto, or shall sign and file with the Director a facsimile thereof prior to commencement or continuation of operation thereunder agreeing to abide by the terms and specifications of the plan. An RPF may be responsible for the conduct of timber operations under contractual arrangements with the timber owner.

CALIFORNIA FOREST PRACTICE RULES

(6) The logging area shall meet the stocking standards described in 14 CCR 913.8(a) within five years following completion of timber operations. Hardwoods, as per 14 CCR 912 "Commercial Species", designated for management may be counted for stocking. If such hardwoods are counted to meet stocking requirements, at least 20% of the total harvest area cut under 14 CCR 913.8(a) shall be planted with conifer trees at the rate of at least 1112 well-distributed trees per ha (450 trees/acre).

(c) The harvest of dead, dying or deteriorating trees resulting from fire, wind, insect, disease, flood, or other injurious agents as provided in 14 CCR 913.3(b) shall be exempt from 14 CCR 913.8(a) and (b) except for stocking under 14 CCR 913.8(b) provided there has been a preharvest inspection and a plan has been approved.

(d) Eucalyptus stands designated for management as a commercial crop may be harvested under the evenage silvicultural system provided the following conditions and limitations are met:

(1) Except as provided in 14 CCR 913.1(a)(2), clearcuts shall be limited to 10 acres in size, and must conform with all other Provisions of 14 CCR 913.1(a).

(2) Clearcut areas shall be screened from direct public view by having screening vegetation between the clearcut area and public areas utilized by substantial numbers of viewers. Screening vegetation shall be a minimum of 100 feet in width. Screening shall be retained until vegetative regrowth effectively covers all areas of visible bare soil.

(3) Regenerated stands may be re-entered for harvest not sooner than ten years after harvest.

953.9 Successive Cutting [Southern only]

ReLogging of an area in less than the period of five years required for meeting stocking standards can be done only under either of the following conditions: (a) Sanitation-salvage cuttings, or (b) When stocking requirements have been met and a report of satisfactory stocking (ref. 14 CCR 1076) has been issued by the Director.

913.10, 933.10, 953.10 Timberland Productivity, Sustained Forestry Planning, Addendum

The goal of this section is to restore, enhance and maintain the productivity of the state's timberlands, where feasible.

(a) Where feasible, the productivity of timberlands shall be maintained on a site-specific basis by

1) Meeting the stocking standards of the selected silvicultural or regeneration method, or that level of stocking above the minimum that will achieve long term sustained yield (LTSY) that is proposed in 913.11 a or b.

2) Proposing and implementing an appropriate silvicultural system and regeneration method for the site,

3) Protecting the soil resource and its ability to grow commercial tree species and provide sustainable associated forest values.

(b) Timberland productivity is restored by mitigating the adverse effects of catastrophic events or previous land use activities in order to improve the site capacity to grow for harvest commercial tree species and provide forest values.

(c) Timberland productivity is enhanced by such means as planting, thinning, stand manipulation, stream channel improvement, or other techniques that will lead to increased tree growth and yield, accumulation of growing stock and production of associated forest values.

(d) Measures implemented to mitigate or avoid adverse environmental impacts of timber harvesting contribute to restoration and enhancement of timberland productivity. Plan submitters are encouraged, but not required, to undertake additional measures to restore and enhance timberland productivity. CDF may advise plan submitters of measures which could be undertaken at the plan submitters' option to further restore and enhance timberland productivity.

(e) This section does not impose any additional obligation on owners of timberlands where wildfires, insects, disease, wind, flood, or other blight caused by an act of nature reduces stocking levels below any applicable stocking requirements.

CALIFORNIA FOREST PRACTICE RULES

913.11, 933.11, 953.11 Maximum Sustained Production of High Quality Timber Products

The goal of this section is the achieve Maximum Sustained Production of High Quality Timber Products (MSP). MSP is achieved by meeting the requirements of either (a) or (b) or (c) in a THP, SYP or NTMP, or as otherwise provided in Article 6.8, Subchapter 7.

(a) Where a Sustained Yield Plan (14 CCR 1091.1) or Nonindustrial Timber Management Plan (NTMP) has not been approved for an ownership, MSP will be achieved by:

(1) Producing the yield of timber products specified by the landowner, taking into account biologic and economic factors, while accounting for limits on productivity due to constraints imposed from consideration of other forest values, including but not limited to, recreation, watershed, wildlife, range and forage, fisheries, regional economic vitality, employment and aesthetic enjoyment.

(2) Balancing growth and harvest over time, as explained in the THP for an ownership, within an assessment area set by the timber owner or timberland owner and agreed to by the Director. For purposes of this subsection the sufficiency of information necessary to demonstrate the balance of growth and harvest over time for the assessment area shall be guided by the principles of practicality and reasonableness in light of the size of the ownership and the time since adoption of this section using the best information available. The projected inventory resulting from harvesting over time shall be capable of sustaining the average annual yield achieved during the last decade of the planning horizon. The average annual projected yield over any rolling 10-year period, or over appropriately longer time periods for ownerships which project harvesting at intervals less frequently than once every ten years, shall not exceed the projected long-term sustained yield.

(3) Realizing growth potential as measured by adequate site occupancy by species to be managed and maintained given silvicultural methods selected by the landowner.

(4) Maintaining good stand vigor.

(5) Making provisions for adequate regeneration. At the plan submitter's option, a THP may demonstrate achievement of MSP pursuant to the criteria established in (b) where an SYP has been submitted but not approved.

(b) Where a SYP or NTMP is submitted for an ownership, an approved SYP or NTMP achieves MSP by providing sustainable harvest yields established by the landowner which will support the production level of those high quality timber products the landowner selects while at the same time:

(1) meeting minimal stocking and basal area standards for the selected silvicultural methods as provided in these rules as described;

(2) protecting the soil, air, fish and wildlife, water resources and any other public trust resources;

(3) giving consideration to recreation, range and forage, regional economic vitality, employment and aesthetic enjoyment;

(4) balancing growth and harvest over time. The projected inventory resulting from harvesting over time shall be capable of sustaining the average annual yield achieved during the last decade of the planning horizon. The average annual projected yield over any rolling 10-year period, or over appropriately longer time periods for ownerships which project harvesting at intervals less frequently than once every ten years, shall not exceed the projected long-term sustained yield. A THP which relies upon and is found to be consistent with an approved SYP shall be deemed adequate to achieve MSP.

(c) In a THP, or NTMP, MSP is achieved by:

(1) For evenage management, meeting the minimum stand age standards of 913.1(a)(1), meeting minimum stocking and basal area standards for the selected silvicultural methods as contained in these rules only with group A species, and protecting the soil, air, fish and wildlife, water resources and other public trust resources through the application of these rules; or

(2) For unevenaged management, complying with the seed tree retention standards pursuant to 913.1(c)(1)(A), meeting minimum stocking and basal area standards for the selected silvicultural methods as contained in these rules only with group A species, and protecting the soil, air, fish and wildlife, water resources and other public trust resources through the application of these rules.

(3) For intermediate treatments and special prescriptions, complying with the stocking requirements of the individual treatment or prescription.

(4) Timberland ownerships totaling 50,000 acres or less may use subsection (c) to show MSP.

CALIFORNIA FOREST PRACTICE RULES

(5) Timberland ownerships of 50,000 acres or more may use subsection (c) through December 31, 1999. Thereafter they may use subsection (c) if an SYP or demonstration of achievement of MSP pursuant to 913.11(a) [933.11(a), 953.11(a)] has been filed with the department and has not been returned unfiled or approved.

(6) For scattered parcels on timberland ownerships of 50,000 acres or more, subsection (c) may be used to show MSP.

953.12 High Use Subdistrict

In the "high use subdistrict," the selection regeneration method, or sanitation-salvage or commercial thinning treatments may be used. An RPF may propose a modification of the selection regeneration method or sanitation-salvage intermediate treatments when explained and justified in the plan (see 14 CCR 953 for alternative prescriptions). In these areas, no trees shall be cut unless first marked on both the bole and stump with either paint, tags or blazes so as to be plainly visible. Such marking shall be done by an RPF or supervised designee sufficiently in advance of cutting to allow for inspection by the Director's representatives. In these areas, the leave stand will be at least 50% of the number of trees 30.5 cm (12 in.) or larger d.b.h. standing prior to the time of harvesting. These leave trees should be in Dunning's tree classes 1, 2, or 3 (Ref. 14 CCR 952 def. Dunning's classification). The composition and distribution of the leave stand shall be maintained as nearly as practical, giving consideration to the esthetics of the areas. Only sanitation-salvage treatment shall be allowed in the cutover areas for 10 years following the harvest.

Article 4 Harvesting Practices and Erosion Control

914, 934, 954 Purposes [All Districts]

Timber operations shall be conducted to: meet the goal of maximum sustained production of high quality timber products; minimize breakage of merchantable timber; prevent unreasonable damage to residual trees, fish and wildlife habitat as identified in the THP, or contained in the rules, reproduction, and riparian vegetation; prevent degradation of the quality and beneficial uses of water; and maintain site productivity by minimizing soil loss. The following provisions shall be applied in a manner which achieves this standard.

914.1, 934.1, 954.1 Felling Practices [All Districts]

The following standards are applicable to felling practices:

(a) To the fullest extent possible and with due consideration given to topography, lean of trees, landings, utility lines, local obstructions, and safety factors, trees shall be felled to lead in a direction away from watercourses and lakes.

(b) Desirable residual trees and tree seedlings of commercial species, [**Southern only: and those oak trees requiring protection pursuant to 14 CCR 959.15**] shall not be damaged or destroyed by felling operations, except where unavoidable due to safety factors, lean of trees, location of obstructions or roads, or lack of sufficient openings to accommodate felled trees.

(c) Trees shall be felled in conformance with watercourse and lake protection measures incorporated in timber harvesting plans and consistent with Article 6 of these rules.

(d) Felling practices shall conform to requirements of 14 CCR 914.4 [934.4, 954.4] to protect bird nesting sites.

(e) [**Southern only**] In the Southern Forest District stumps shall be kept to a height of 30.5 cm (12 in.), and in the High Use Subdistrict stumps shall be kept to a height of 20.3 cm (8 in.), or less on the side adjacent to the highest ground level, except where safety, imbedded metal, or unmerchantable wood make this impractical.

914.2, 934.2, 954.2 Tractor Operations [All Districts]

The following standards are applicable to tractor operations:

(a) Tractor operations shall be conducted in a manner which complies with 14 CCR 914 [934, 954].

(b) Tractor, or other heavy equipment which is equipped with a blade, shall not operate on skid roads or slopes that are so steep as to require the use of the blade for braking.

(c) Tractor roads shall be limited in number and width to the minimum necessary for removal of logs.

CALIFORNIA FOREST PRACTICE RULES

When less damage to the resources specified in 14 CCR 914 [934, 954] will result, existing tractor roads shall be used instead of constructing new tractor roads.

(d) Heavy equipment shall not operate on unstable areas. If such areas are unavoidable, the RPF shall develop specific measures to minimize the effect of operations on slope instability. These measures shall be explained and justified in the plan and must meet the requirements of 14 CCR 914 [934, 954].

(e) Slash and debris from timber operations shall not be bunched adjacent to residual trees required for silvicultural or wildlife purposes, or placed in locations where they could be discharged into a Class I or II watercourse, or lake.

(f) [Coast only] Tractor operations shall be subject to the following limitations:

(1) Heavy equipment shall be prohibited where any of the following conditions are present:

(i) Slopes steeper than 65%.

(ii) Slopes steeper than 50% where the erosion hazard rating is high or extreme.

(iii) Slopes over 50% which lead without flattening to sufficiently dissipate water flow and trap sediment before it reaches a watercourse or lake.

(2) On slopes between 50 percent and 65 percent where the erosion hazard rating is moderate, and all slope percentages are for average slope steepness based on sample areas that are 20 acres, or less if proposed by the RPF or required by the Director, heavy equipment shall be limited to:

(i) Existing tractor roads that do not require reconstruction, or

(ii) New tractor roads at a location that has been shown on the THP map, flagged by an RPF or supervised designee prior to the pre-harvest inspection or, when a pre-harvest inspection is not required, prior to the start of timber operations, and approved by the Director.

(3) The RPF may propose exceptions to the limitations on tractor operations described above, if the proposed exception will comply with 14CCR 914 [934, 954], and if the THP both clearly explains the proposed exception and justifies why application of the standard rule is either not feasible, or would not comply with 14CCR 914 [934, 954]. The location of tractor roads to be used under such exceptions shall be flagged prior to the pre-harvest inspection or, when a pre-harvest inspection is not required, prior to the start of timber operations.

(f) [Northern and Southern only] Tractor operations shall be subject to the following limitations:

(1) Heavy equipment shall be prohibited where any of the following conditions are present:

(i) Slopes steeper than 65%.

(ii) Slopes steeper than 50% where the erosion hazard rating is high or extreme.

(iii) Slopes over 50% which lead without flattening to sufficiently dissipate water flow and trap sediment before it reaches a watercourse or lake.

(2) On slopes between 50 percent and 65 percent where the erosion hazard rating is moderate, and all slope percentages are for average slope steepness based on sample areas that are 20 acres, or less if proposed by the RPF or required by the Director, heavy equipment shall be limited to:

(i) Existing tractor roads that do not require reconstruction, or

(ii) New tractor roads that have been flagged by an RPF or supervised designee prior to use.

(3) The RPF may propose exceptions to the limitations on tractor operations described above, if the proposed exception will comply with 14CCR 934 [954], and if the THP both clearly explains the proposed exception and justifies why application of the standard rule is either not feasible, or would not comply with 14CCR 934 [954]. The location of tractor roads to be used under such exceptions shall be flagged prior to the pre-harvest inspection or, when a pre-harvest inspection is not required, prior to the start of timber operations.

(g) Where tractor roads are constructed, timber operators shall use tractor roads only, both for skidding logs to landings and on return trips.

(h) Timber operators shall exercise due diligence so that desirable residual trees and seedlings will not be damaged or destroyed in tractor operations.

(i) Where waterbreaks cannot effectively disperse surface runoff, other erosion controls shall be installed as needed.

(j) [Southern only] Except where terracing will disturb less than 50 percent of the soil surface, mechanical site preparation shall not be conducted on any of the following:

(1) Any slopes over 40%.

(2) Slopes over 30% which lead without flattening to a Class I or Class II watercourse or to a lake.

CALIFORNIA FOREST PRACTICE RULES

(3) Areas having average slopes over 30%, where the erosion hazard rating is high or extreme. The area sampled for the average shall not exceed 20 acres.

(k) [Southern only] The Director may approve exceptions to (j)(1), (j)(2) and (j)(3) above when damage to soil and water quality caused by the use of heavy equipment will not exceed that caused by other site preparation methods if explained and justified in the THP.

914.3, 934.3, 954.3 Cable Yarding [All Districts]

The following standards are applicable to cable yarding:

(a) Due diligence shall be exercised in the installing, and operating, of cable lines so that residual trees will not incur unreasonable damage by such installation or use.

(b) Residual trees required to be left upon completion of timber operations shall not be used for rub trees, corner blocks, rigging or other cable ties unless effectively protected from damage.

(c) The practice of tight-lining for the purpose of changing location of cable lines is prohibited unless such practice can be carried on without damaging residual trees.

(d) Cable yarding settings shall take maximum advantage of the natural topography and timber types so that yarding operations will protect residual trees.

(e) Tractors shall not be used in areas designated for cable yarding except to pull trees away from streams, to yard logs in areas where deflection is low, or where swing yarding is advantageous, to construct firebreaks and/or layouts, and to provide tail-holds. Such exception(s) shall be explained and justified in the THP, and require Director's approval.

954.4 Site Preparation Addendum [Southern only]

Where site preparation will occur on the logging area, the THP shall incorporate a site preparation addendum (also see 955.4) which includes the following information:

(a) Whether site preparation will be required to meet stocking.

(b) The general methods of site preparation to be used.

(c) The types of equipment (if any) to be used for mechanical site preparation and firebreak construction.

(d) The methods for protecting any desirable residual trees in accordance with 14 CCR 957.7.

(e) Explanations and justifications for any exceptions or alternatives to the standard rules.

(f) A map identifying the boundaries of site preparation areas, if different from logging area boundaries, and distinguishing areas by type of site preparation activity.

(g) The name, address, and telephone number of the person responsible for conduct of site preparation activities.

(h) The estimated timing of site preparation operations.

914.5, 934.5, 954.5 Servicing of Logging Equipment, Disposal of Refuse, Litter, Trash and Debris [All Districts]

The following standards shall be adhered to in servicing logging equipment and disposing of refuse, litter, trash and debris:

(a) Equipment used in timber operations shall not be serviced in locations where servicing will allow grease, oil, or fuel to pass into lakes or watercourses.

(b) Non-biodegradable refuse, litter, trash, and debris resulting from timber operations, and other activity in connection with the operations shall be disposed of concurrently with the conduct of timber operations.

914.6, 934.6, 954.6 Waterbreaks [All Districts, with variation]

The following standards are applicable to the construction of waterbreaks:

(a) except as otherwise provided for in the rules:

(1) All waterbreaks shall be installed no later than the beginning of the winter period of the current year of timber operations.

(2) Installation of drainage facilities and structures is required from October 15 to November 15 and from April 1 to May 1 on all constructed skid trails and tractor roads prior to sunset if the National Weather Service forecast is a "chance" (30% or more) of rain within the next 24 hours.

CALIFORNIA FOREST PRACTICE RULES

(b) Waterbreaks shall be constructed concurrently with the construction of firebreaks and immediately upon conclusion of use of tractor roads, roads, layouts, and landings which do not have permanent and adequate drainage facilities, or drainage structures.

(c) Distances between waterbreaks shall not exceed the following standards:

MAXIMUM DISTANCE BETWEEN WATERBREAKS

Estimated Hazard Rating	U.S. Equivalent Measure Road or Trail Gradient (in percent)				Metric Measure Road or Trail Gradient (in percent)			
	10 or less	11-25	26-50	>50	10 or less	11-25	26-50	>50
	Feet	Feet	Feet	Feet	Meters	Meters	Meters	Meters
Extreme	100	75	50	50	30.48	22.86	15.24	15.24
High	150	100	75	50	45.72	30.48	22.35	15.24
Moderate	200	150	100	75	60.96	45.72	30.48	22.35
Low	300	200	150	100	91.44	60.96	45.72	30.48

The appropriate waterbreak spacing shall be based upon the erosion hazard rating and road or trail gradient.

(d) Cable roads that are so deeply cut as to divert and carry water away from natural drainage patterns for more than 100 feet shall have waterbreaks installed on them at 100 feet intervals, or other appropriate erosion control measure may be applied if specified in the plan.

(e) Waterbreaks shall be installed at all natural watercourses on tractor roads and firebreaks regardless of the maximum distances specified in this section, except where permanent drainage facilities are provided.

(f) Waterbreaks shall be located to allow water to be discharged into some form of vegetative cover, duff, slash, rocks, or less erodible material wherever possible, and shall be constructed to provide for unrestricted discharge at the lower end of the waterbreak so that water will be discharged and spread in such a manner that erosion shall be minimized. Where waterbreaks cannot effectively disperse surface runoff, including where waterbreaks on roads and skid trail cause surface run-off to be concentrated on downslopes, roads or skid trails, other erosion controls shall be installed as needed to comply with Title 14 CCR 914 [934, 954].

(g) Waterbreaks shall be cut diagonally a minimum of 15.2 cm (6 inches) into the firm roadbed, cable road, skid trail or firebreak surface and shall have a continuous firm embankment of at least 15.2 cm (6 in.) in height immediately adjacent to the lower edge of the waterbreak cut.

[Coast only]: In the Southern Subdistrict of the Coast Forest District, on truck roads having firmly compacted surfaces, waterbreaks installed by hand methods need not provide the additional 15.2 cm (6 in.) embankment provided the waterbreak ditch is constructed so that it is at least 15.2 cm (6 in.) deep and 15.2 cm (6 in.) wide on the bottom and provided there is ample evidence based on slope, material, amount of rainfall, and period of use that the waterbreaks so constructed will be effective in diverting water flow from the road surface without the embankment.

(h) Waterbreaks or any other erosion controls on skid trails, cable roads, layouts, firebreaks, abandoned roads, and site preparation areas shall be maintained during the prescribed maintenance period and during timber operations as defined in PRC Sections 4527 and 4551.5 so that they continue to function in a manner which minimizes soil erosion and slope instability and which prevents degradation of the quality and beneficial uses of water. The method and timing of waterbreak repair and other erosion control maintenance shall be selected with due consideration given to the protection of residual trees and reproduction and the intent of 14 CCR 914 [934, 954].

(i) The prescribed maintenance period for waterbreaks and any other erosion control facilities on skid trails, cable roads, layouts, firebreaks, abandoned roads, and site preparation areas, shall be at least one year. The Director may prescribe a maintenance period extending as much as three years after filing of the work completion report in accordance with 14 CCR 1050.

CALIFORNIA FOREST PRACTICE RULES

914.7, 934.7, 954.7 Timber Operations, Winter Period [All Districts]

During the winter period:

(a) Mechanical site preparation and timber harvesting, shall not be conducted unless a winter period operating plan is incorporated in the timber harvesting plan and is followed, or unless the requirements of subsection (c) are met. Cable, helicopter and balloon yarding methods are exempted.

(b) The winter period operating plan shall include the specific measures to be taken in winter timber operations to minimize damage due to erosion, soil movement into watercourses and soil compaction from felling, yarding, loading, mechanical site preparation, and erosion control activities. A winter period operating plan shall address the following subjects:

- (1) Erosion hazard rating.
- (2) Mechanical site preparation methods.
- (3) Yarding system (constructed skid trails).
- (4) Operating Period.
- (5) Erosion control facilities timing.
- (6) Consideration of form of precipitation-rain or snow.
- (7) Ground conditions (soil moisture condition, frozen).
- (8) Silvicultural system-ground cover.
- (9) Operations within the WLPZ.
- (10) Equipment use limitations.
- (11) Known unstable areas.

(c) In lieu of a winter period operating plan, the RPF can specify the following measures in the THP:

(1) Tractor yarding or the use of tractors for constructing layouts, firebreaks or other tractor roads shall be done only during dry, rainless periods where soils are not saturated.

(2) Erosion control structures shall be installed on all constructed skid trails and tractor roads prior to the end of the day if the U.S. Weather Service forecast is a "chance" (30% or more) of rain before the next day, and prior to weekend or other shutdown periods.

(3) Site specific mitigation measures needed to comply with 14 CCR 914 [934, 954] for operations within the WLPZ and unstable areas during the winter period.

The provisions of subsection (c) do not apply to mechanical site preparation.

914.8, 934.8, 954.8 Tractor Road Watercourse Crossing [All Districts]

Watercourse crossing facilities on tractor roads shall be planned, constructed, maintained, and removed according to the following standards:

(a) The number of crossings shall be kept to a minimum. Existing crossing locations shall be used wherever feasible.

(b) A prepared watercourse crossing using a structure such as a bridge, culvert, or temporary log culvert shall be used to protect the watercourse from siltation where tractor roads cross a watercourse in which water may be present during the life of the crossing.

(c) Crossing facilities on watercourses that support fish shall allow for unrestricted passage of all life stages of fish that may be present, and for unrestricted passage of water. Such crossing facilities shall be fully described in sufficient clarity and detail to allow evaluation by the review team and the public, provide direction to the LTO for implementation, and provide enforceable standards for the inspector.

(d) Watercourse crossing facilities not constructed to permanent crossing standards on tractor roads shall be removed before the beginning of the winter period. If a watercourse crossing is to be removed, it shall be removed in accordance with 14 CCR 923.3(d) [943.3(d), 963.3(d)].

(e) If the watercourse crossing involves a culvert, the minimum diameter shall be stated in the THP and the culvert shall be of a sufficient length to extend beyond the fill material.

(f) Consistent with the protection of water quality, exceptions may be provided through the Fish and Game Code and shall be indicated in the plan.

(g) The amendments to 14 CCR § 914.8 [934.8, 954.8] that became effective July 1, 2000 shall expire on December 31, 2002.

CALIFORNIA FOREST PRACTICE RULES

914.9, 934.9, 954.9 Alternatives to Standard Rules [All Districts]

(a) Alternative practices may be developed by the RPF on a site-specific basis provided the following conditions are complied with and the alternative practices will achieve environmental protection at least equal to that which would result from using measures stated in Sections 914.1-914.8 [934.1-934.8, 954.1-954.8].

(1) Environmental impacts with potential for significant adverse effects on the beneficial uses of water, on the residual timber, and on the soil productivity are identified and measures proposed to mitigate such impacts are included in an approved THP. The THP shall also contain a clear statement as to why alternative harvesting and erosion control measures are needed.

(2) The alternative practice(s) must be explained in sufficient detail and standards provided in the THP so that they can be adequately evaluated and enforced by the Director and implemented by the licensed timber operator.

(3) On a THP in which alternatives covering harvesting and erosion control measures have been incorporated, the timber operator shall agree to the alternative specifications by signing and filing with the Director a copy of the plan, the amended plan or a facsimile thereof, prior to beginning or continuing operations on the portion of the plan to which the alternatives apply.

(b) The Director shall not accept for inclusion in a THP alternative harvesting and erosion control measures proposed under this section which do not meet the standard of subsection (a) of this section. In the event that there is more than one written negative position showing that the alternative practice(s) does (do) not meet the standard of subsection (a) received from among the agencies listed in 14 CCR 1037.3 and the Department which participated in the review of the plan including on-the-ground inspection, the Director shall reject the proposed alternative.

(c) Alternative practices stated in an approved THP shall have the same force and authority as those practices required by the standard rule.

Article 5 Site Preparation

915, 935, 955 Purposes [All Districts]

Site preparation shall be planned and conducted in a manner which encourages maximum timber productivity, minimizes fire hazards, prevents substantial adverse effects to soil resources and to fish and wildlife habitat, and prevents degradation of the quality and beneficial uses of water. The following provisions shall be applied in a manner which complies with this standard.

915.1, 935.1, 955.1 Use of Heavy Equipment for Site Preparation [All Districts]

(a) Use of heavy equipment for site preparation shall comply with the provisions set forth in 14 CCR 914.2 [934.2, 954.2].

(b) Heavy equipment shall not be used for site preparation under saturated soil conditions or when it cannot operate under its own power due to wet conditions.

(c) Watercourse crossings for heavy equipment shall be planned, constructed, maintained, and removed in accordance with the requirements for tractor roads in 14 CCR 914.8 [934.8, 954.8].

(d) Undisturbed areas or energy dissipators shall be used to control and disperse concentrated runoff from roads, landings, tractor roads, firebreaks and erosion control facilities where it flows into site preparation areas.

915.2, 935.2, 955.2 Treatment of Vegetative Matter [All Districts]

(a) Piling, burning, and other treatment of snags, slash and vegetative matter and protection of desirable residual trees during site preparation shall comply with 14 CCR 917 [937, 957] through 917.7 [937.7, 957.7].

(b) Broadcast burning shall not fully consume the larger organic debris which retains soil on slopes and stabilizes watercourse banks. The Director may approve exceptions to this requirement when such exceptions are explained and justified in the THP and the exceptions would provide for the protection of the beneficial uses of water or control erosion to a standard at least equal to that which would result from application of the standard rule.

CALIFORNIA FOREST PRACTICE RULES

915.3, 935.3, 955.3 Protection of Natural Resources [All Districts]

(a) Site preparation activities shall comply with the watercourse and lake protection requirements in 14 CCR Article 6 and 917.3 [937.3, 957.3].

(b) Site preparation activities shall comply with the wildlife and habitat protection provisions of 14 CCR Article 9.

(c) Site preparation shall be performed in a manner which does not deleteriously affect species which are threatened, endangered, or designated by the Board as species of special concern. The Director may allow exceptions to this standard in the plan, after consultation with the Department of Fish and Game pursuant to the California Endangered Species Act (F&G Code 2050-2098).

915.4, 935.4, 955.4 Site Preparation Addendum [All Districts]

Where site preparation will occur on the logging area, the THP shall incorporate a site preparation addendum which includes the following information:

(a) Whether site preparation will be required to meet stocking.

(b) The general methods of site preparation to be used.

(c) The types of equipment, if any, to be used for mechanical site preparation and firebreak construction.

(d) The methods for protecting any desirable residual trees in accordance with 14 CCR 917.7 [937.7, 957.7].

(e) Explanations and justifications for any exceptions or alternatives to the standard rules.

(f) A map identifying the boundaries of site preparation areas, if different from logging area boundaries, and distinguishing areas by type of site preparation activity.

(g) The name, address, and telephone number of the person responsible for conduct for site preparation activities shall be provided prior to conducting site preparation activities.

(h) The estimated timing of site preparation operations.

Article 6 Watercourse and Lake Protection

916, 936, 956 Intent of Watercourse and Lake Protection [All Districts]

The purpose of this article is to ensure that the beneficial uses of water, native aquatic and riparian species, and the beneficial functions of riparian zones are protected from potentially significant adverse site-specific and cumulative impacts associated with timber operations.

It is the intent of the Board to restore, enhance, and maintain the productivity of timberlands while providing equal consideration for the beneficial uses of water. Further, it is the intent of the Board to clarify and assign responsibility for recognition of potential and existing impacts of timber operations on watercourses and lakes, native aquatic and riparian-associated species, and the beneficial functions of riparian zones and to ensure adoption of feasible measures to effectively achieve compliance with this article. Further, it is the intent of the Board that the evaluations that are made, and the measures that are taken or prescribed, be documented in a manner that clearly and accurately represents those existing conditions and those measures. "Evaluations made" pertain to the assessment of the conditions of the physical form, water quality, and biological characteristics of watercourses and lakes, including cumulative impacts affecting the beneficial uses of water on both the area of planned logging operations and in the Watershed Assessment Area (WAA). "Measures taken" pertain to the procedures used or prescribed for the restoration, enhancement, and maintenance of the beneficial uses of water.

All provisions of this article shall be applied in a manner, which complies with the following:

(a) During and following timber operations, the beneficial uses of water, native aquatic and riparian-associated species, and the beneficial functions of riparian zones shall be maintained where they are in good condition, protected where they are threatened, and insofar as feasible, restored where they are impaired.

(b) Protection of the quality and beneficial uses of water during the planning, review, and conduct of timber operations shall comply with all applicable legal requirements including those set forth in any applicable water quality control plan adopted or approved by the State Water Resources Control Board. At a minimum, the LTO shall not do either of the following during timber operations:

CALIFORNIA FOREST PRACTICE RULES

(1) Place, discharge, or dispose of or deposit in such a manner as to permit to pass into the waters of the state, any substances or materials, including, but not limited to, soil, silt, bark, slash, sawdust, or petroleum, in quantities deleterious to fish, wildlife, beneficial functions of riparian zones, or the quality and beneficial uses of water;

(2) Remove water, trees or large woody debris from a watercourse or lake, the adjacent riparian area, or the adjacent flood plain in quantities deleterious to fish, wildlife, beneficial functions of riparian zones, or the quality and beneficial uses of water.

(c) Protecting and restoring native aquatic and riparian-associated species, the beneficial functions of riparian zones and the quality and beneficial uses of water shall be given equal consideration as a management objective within any prescribed WLPZ and within any ELZ or EEZ designated for watercourse or lake protection.

(d) The measures set forth in this Section are meant to enforce the public's historical and legal interest in protection for wildlife, fish, and water quality and are to be used to guide timberland owners in meeting their legal responsibilities to protect public trust resources.

(e) The amendments to 14 CCR §§ 916 [936, 956] that became effective July 1, 2000 shall expire on December 31, 2002.

916.1, 936.1, 956.1 In Lieu Practices [All Districts]

In rule sections where provision is made for site specific practices to be proposed by the RPF, approved by the Director and included in the THP in lieu of a stated rule, the RPF shall reference the standard rule, shall explain and describe each proposed practice, how it differs from the standard practice, and the specific locations where it shall be applied; and shall explain and justify how the protection provided by the proposed practice is at least equal to the protection provided by standard rule.

(a) The in lieu practice(s) must provide for the protection of the beneficial uses of water to the standards of 14 CCR 916.3 [936.3, 956.3] and 916.4(b) [936.4(b), 956.4(b)].

(b) In lieu practices stated in an approved THP shall have the same enforceability and legal authority as those practices required by the standard rules.

(c) Any in lieu practices which propose less than standard rule WLPZ widths for Class I watercourses shall include 14 CCR 916.5.(e) [936.5(e), 956.5(e)] "A" & "D" protection measures.

916.2, 936.2, 956.2 Protection of the Beneficial Uses of Water and Riparian Functions [All Districts]

(a) The measures used to protect each watercourse and lake in a logging area shall be determined by the presence and condition of the following values:

(1) The existing and restorable quality and beneficial uses of water as specified by the applicable water quality control plan and as further identified and refined during preparation and review of the plan.

(2) The restorable uses of water for fisheries as identified by the DFG or as further identified and refined during preparation and review of the plan.

(3) Riparian habitat that provides for the biological needs of native aquatic and riparian-associated species as specified in 14 CCR 916.4(b) [936.4(b), 956.4(b)].

(4) Sensitive conditions near watercourses and lakes as specified in 14 CCR 916.4(a) [936.4(a), 956.4(a)].

These values shall be protected from potentially significant adverse impacts from timber operations and restored to good condition, where needed, through a combination of the rules and plan-specific mitigation. The RPF shall propose and the Director may require, adequate protection of overflow and changeable channels which are not contained within the channel zone.

(b) The State's waters are grouped into four classes based on key beneficial uses. These classifications shall be used to determine the appropriate minimum protection measures to be applied during the conduct of timber operations. The basis for classification (characteristics and key beneficial uses) are set forth in 14 CCR 916.5 [936.5, 956.5], Table 1 and the range of minimum protective measures applicable to each class are contained in 14 CCR 916.3 [936.3, 956.3], 916.4 [936.4, 956.4], and 916.5 [936.5, 956.5].

(c) When the protective measures contained in 14 CCR 916.5 [936.5, 956.5] are not adequate to provide protection to beneficial uses, feasible protective measures shall be developed by the RPF or proposed by the Director under the provisions of 14 CCR 916.6 [936.6, 956.6], Alternative Watercourse and Lake Protection, and incorporated in the plan when approved by the Director.

CALIFORNIA FOREST PRACTICE RULES

(d) The amendments to 14 CCR § 916.2 [936.2, 956.2] that became effective July 1, 2000 shall expire on December 31, 2002.

916.3, 936.3, 956.3 General Limitations Near Watercourses, Lakes, Marshes, Meadows and Other Wet Areas [All Districts]

The quality and beneficial uses of water shall not be unreasonably degraded by timber operations. During timber operations, the timber operator shall not place, discharge, or dispose of or deposit in such a manner as to permit to pass into the water of this state, any substances or materials, including, but not limited to, soil, silt, bark, slash, sawdust, or petroleum, in quantities deleterious to fish, wildlife, or the quality and beneficial uses of water. All provisions of this article shall be applied in a manner which complies with this standard.

(a) When there is reasonable expectation that slash, debris, soil, or other material resulting from timber operations, falling or associated activities, will be deposited in Class I and Class II waters below the watercourse or lake transition line or in watercourses which contain or conduct Class IV water, those harvest activities shall be deferred until equipment is available for its removal, or another procedure and schedule for completion of corrective work is approved by the Director.

(b) Accidental depositions of soil or other debris in lakes or below the watercourse or lake transition line in waters classed I, II, and IV shall be removed immediately after the deposition or as approved by the Director.

(c) The timber operator shall not construct or reconstruct roads, construct or use tractor roads or landings in Class I, II, III or IV watercourses, in the WLPZ, marshes, wet meadows, and other wet areas unless when explained and justified in the THP by the RPF, and approved by the Director, except as follows:

- (1) At prepared tractor road crossings as described in 914.8(b) [934.8(b), 954.8(b)].
- (2) Crossings of Class III watercourses which are dry at the time of timber operations.
- (3) At existing road crossings.

(4) At new tractor and road crossings approved as part of the Fish and Game Code process (F&GC 1600 et seq.).

Use of existing roads is addressed in 916.4(a) [936.4(a), 956.4(a)].

(d) Vegetation, other than commercial species, bordering and covering meadows and wet areas shall be retained and protected during timber operations unless explained and justified in the THP and approved by the Director. Soil within the meadows and wet areas shall be protected to the maximum extent possible.

(e) Trees cut within the WLPZ shall be felled away from the watercourse by pulling or other mechanical methods if necessary, in order to protect the residual vegetation in the WLPZ. Exceptions may be proposed in the THP and used when approved by the Director.

(f) Where less than 50% canopy exists in the WLPZs of Class I and II waters before timber operations, only sanitation salvage which protects the values described in 14 CCR 916.4(b) [936.4(b), 956.4(b)] shall be allowed.

(g) Recruitment of large woody debris for instream habitat shall be provided by retaining at least two living conifers per acre at least 16 inches diameter breast high and 50 ft. tall within 50 ft. of all Class I and II watercourses.

916.4, 936.4, 956.4 Watercourse and Lake Protection [All Districts]

(a) The RPF or supervised designee shall conduct a field examination of all lakes and watercourses and shall map all lakes and watercourses which contain or conduct Class I, II, III or IV waters.

(1) As part of this field examination, the RPF or supervised designee shall evaluate areas near, and areas with the potential to directly impact, watercourses and lakes for sensitive conditions including, but not limited to, existing and proposed roads, skidtrails and landings, unstable and erodible watercourse banks, unstable upslope areas, debris, jam potential, inadequate flow capacity, changeable channels, overflow channels, flood prone areas, and riparian zones wherein the values set forth in 14 CCR §§ 916.4(b) [936.4(b), 956.4(b)] are impaired. The RPF shall consider these conditions, and those measures needed to maintain, and restore to the extent feasible, the functions set forth in 14 CCR §§ 916.4(b) [936.4(b), 956.4(b)], when proposing WLPZ widths and protection measures. The plan shall identify such conditions, including where they may interact with proposed timber operations, that individually or cumulatively significantly and adversely affect the beneficial uses of water, and shall describe measures to protect and restore to the extent feasible, the beneficial uses of water. In proposing, reviewing, and approving such measures, preference shall be given to measures that are on-site, or

CALIFORNIA FOREST PRACTICE RULES

to offsite measures where sites are located to maximize the benefits to the impacted portion of a watercourse or lake.

(2) As part of this field examination, the RPF or supervised designee shall map the location of spawning and rearing habitat for anadromous salmonids, and the condition of the habitat shall be evaluated using habitat typing that at a minimum identifies the pool, flatwater, and riffle percentages. The opportunity for habitat restoration shall be described within the plan for each Class I watercourse, and for each Class II watercourse that can be feasibly restored to a Class I.

(3) The mapping of conditions identified in subsection (a)(1) and (a)(2) above, and their protective measures, shall be sufficiently clear and detailed to permit the Director and the other review team representatives to evaluate the potential environmental impacts of timber operations, the proposed mitigation measures and the proposed restoration measures.

(4) The mapping of conditions identified in subsection (a)(1) and (a)(2) above, and their protective measures, shall be sufficiently clear and detailed to provide direction and clear guidance to the timber operator.

(5) The mapping of conditions identified in 14 CCR § 916.4 [936.4, 956.4] subsections (a)(1) and (a)(2), and their protective and restoration measures, should be done at a scale of 1:2,400. In site-specific cases, the mapping of critical locations of corrective work and logging operation impacts shall be done at a scale of at least 1:240 when the Director determines it is necessary to evaluate the plan.

(6) One set of photocopies of recent stereo aerial photographs of the plan area may be required by the Director.

(b) The standard width of the WLPZ and/or the associated basic protection measures shall be determined from Table I (14 CCR 916.5 [936.5, 956.5]) or Section 916.4(c) [956.4(c), 956.4(c)], and shall be stated in the plan. A combination of the rules, the plan, and mitigation measures shall provide protection for the following:

- a. Water temperature control.
- b. Streambed and flow modification by large woody debris.
- c. Filtration of organic and inorganic material.
- d. Upslope stability.
- e. Bank and channel stabilization.
- f. Spawning and rearing habitat for salmonids
- g. Vegetation structure diversity for fish and wildlife habitat, possibly including but not limited to:
 1. Vertical diversity
 2. Migration corridor
 3. Nesting, roosting, and escape
 4. Food abundance
 5. Microclimate modification
 6. Snags
 7. Surface cover

(1) Measures and the appropriate zone widths for the protection of the State's waters which have been taken from Table I (14 CCR 916.5 [936.5, 956.5]) or developed under Section 916.4(c) [936.4(c), 956.4(c)] shall be stated in the THP.

(2) All timber operations shall conform to the marking, flagging and other identification of protective measures specified in CCR 916.4 [936.4, 956.4] and 916.5 [936.5, 956.5] and the THP. Conformance shall be determined based on the evaluation of no less than a 200 foot lineal segment of each watercourse or lake.

(3) The width of the WLPZ shall be measured along the surface of the ground from the watercourse or lake transition line or in the absence of riparian vegetation from the top edge of the watercourse bank.

(4) Slopes shall be measured in percent for the proposed WLPZ. If topography within the proposed WLPZ is variable, segments of the proposed WLPZ should be segregated by slope class as indicated in Table I, 14 CCR 916.5 [936.5, 956.5].

(5) If requested by either party, and after on-the-ground inspection, the RPF and the Director may increase or decrease the width of a proposed WLPZ. A decrease shall not exceed 25 percent of the width as determined by the procedure prescribed in Sections 14 CCR 916.4(c) [936.4(c), 956.4(c)], and 916.5 [936.5, 956.5]. Such changes in zone width shall be based on considerations of soil, slope, climatic factors, biologic, hydrologic, and geologic values listed in Section 14 CCR 916.4(b) [936.4(b), 956.4(b)], silvicultural methods, yarding systems, road location, and site preparation activities. In no case shall the width be adjusted to less than 50 feet for Class I and II waters. Where soil surfaced roads exist within the standard WLPZ, no in-lieu reduction of WLPZ width shall be approved.

CALIFORNIA FOREST PRACTICE RULES

(6) Within the WLPZ, at least 75% surface cover and undisturbed area shall be retained to act as a filter strip for raindrop energy dissipation, and for wildlife habitat. This percentage may be adjusted to meet site specific conditions when proposed by the RPF and approved by the Director or where broadcast burning is conducted under the terms of a project type burning permit and in compliance with 14 CCR 915.2(b) [935.2(b), 955.2(b)].

(c) The protection and WLPZ widths for Class III and Class IV waters shall prevent the degradation of the downstream beneficial use of water and shall be determined on a site-specific basis.

(1) Where operations occur adjacent to Class III watercourses, the RPF shall designate in the THP an equipment limitation zone (ELZ) of at least 25 feet where sideslope steepness is less than 30% and at least 50 feet where sideslope steepness is 30% or greater unless explained and justified otherwise in the THP and approved by the Director. Class III watercourses within logging areas where the EHR is Low and the slopes are less than 30% shall not require an ELZ unless proposed by the RPF or required by the Director. The RPF shall describe the limitations on the use of heavy equipment in the THP. Where appropriate to protect the beneficial uses of water the RPF shall describe additional protection measures which may include surface cover retention, vegetation protection and timber falling limitations. The location of the areas of heavy equipment use in any ELZ shall be clearly described in the plan, or flagged or marked on the ground before the preharvest inspection. When necessary to protect the beneficial use of water, the RPF shall designate and the Director may require a WLPZ for Class III and Class IV waters or an ELZ for Class IV waters.

(2) The width of the WLPZ for Class III and IV waters shall be determined from on-site inspection. Minimum protective measures required when Class III and Class IV protection zones are necessary are contained in Table I 14 CCR 916.5 [936.5, 956.5].

(3) Soil deposited during timber operations in a Class III watercourse other than at a temporary crossing shall be removed and debris deposited during timber operations shall be removed or stabilized before the conclusion of timber operations, or before October 15. Temporary crossings shall be removed before the winter period, or as approved by the Director.

(4) When approved by the Director on an individual plan basis as provided in Section 14 CCR 916.4(c)(1) [936.4(c)(1), 956.4(c)(1)] Class IV waters shall be exempted from required protection when such protection is inconsistent with the management objectives of the owner of the manmade watercourse.

(d) Heavy equipment shall not be used in timber falling, yarding, or site preparation within the WLPZ unless such use is explained and justified in the THP and approved by the Director.

(e) Flagging for heavy equipment use within the WLPZ adjacent to Class I waters and for all tractor road watercourse crossings of all watercourses must be completed before the preharvest inspection if one is conducted or start of operations, whichever comes first. Flagging for heavy equipment use within the WLPZ adjacent to Class II, III and IV waters may be done at the option of the RPF or as required by the Director on a site-specific basis.

(f) Subsection (d) does not apply to (1)-(4) below. Subsection (e) does not apply to (2)-(4) below.

(1) At prepared tractor road crossings as described in 914.8(b) [934.6(b), 954.8(b)].

(2) Crossings of Class III watercourses which are dry at the time of timber operations.

(3) At existing road crossings.

(4) At new tractor and road crossings approved as part of the Fish and Game Code Process (F&GC 1600 et seq.).

916.5, 936.5, 956.5 Procedure for Determining Watercourse and Lake Protection Zone (WLPZ) Widths and Protective Measures [All Districts]

The following procedure for determining WLPZ widths and protective measures shall be followed:

(a) The following information shall be determined from field investigation:

(1) The location of all lakes and watercourses including man made watercourses.

(2) The existing and restorable beneficial uses of the waters to be protected as identified in subsection (1) above.

CALIFORNIA FOREST PRACTICE RULES

(3) The side slope classes for the individual class of waters to be protected (e.g. < 30%, 30-50%, >50%), where side slope is measured from the watercourse or lake transition line to a point 100 feet upslope from the watercourse or lake transition line, or, in the absence of riparian vegetation, from the top of the watercourse bank where slope configurations are variable, a weighted average method shall be used to determine sideslope percent.

(b) The beneficial uses noted from the field investigations in subsection (a) shall be compared to the characteristics or key beneficial uses listed in Row 1 of Table I (14 CCR 916.5 [936.5, 956.5]) to determine the water classes (e.g. I, II, III, IV, Row 2).

(c) The standard protection zone width differentiated by slope classes determined in Subsection (a) are shown in Rows 4-7, Table I (14 CCR 916.5 [936.5, 956.5]). These widths may be modified as stated in 14 CCR 916.4(b)(5) [936.4(b)(5), 956.4(b)(5)].

(d) The alphabetical letter designations A through I in Rows 4-7, Table 1 14 CCR 916.5 [936.5, 956.5], and described in subsection (e) to Table I indicate the standard protective measures to be applied to the classes of water as determined in subsection (b) above.

(e) The letter designations shown in the "Protective Measures and Widths" column in Table I correspond to the following:

"A" WLPZ shall be clearly identified on the ground by the RPF who prepared the plan, or supervised designee, with paint, flagging, or other suitable means prior to the preharvest inspection.

"B" WLPZ shall be clearly identified on the ground by an RPF, or supervised designee, with paint, flagging, or other suitable means, prior to the start of timber operations. *[In planning watersheds determined to contain coho salmon, chinook salmon, or steelhead, on the ground identification of the WLPZ must be completed prior to the preharvest inspection.] [NOTE: This coho section was approved by the Board but inadvertently omitted from approval by the OAL. The Board, CDF, OAL and Barclays are correcting this error.]*

"C" In site-specific cases, the RPF may provide in the plan, or the Director may require, that the WLPZ be clearly identified on the ground with flagging or by other suitable means prior to the start of timber operations.

"D" To ensure retention of shade canopy filter strip properties of the WLPZ and the maintenance of a multi-storied stand for protection of values described in 14 CCR 916.4(b) [936.4(b), 956.4(b)], a base mark below the cut line of residual or harvest trees within the zone shall be done in advance of the preharvest inspection by the RPF or supervised designee. *[Except in planning watersheds determined to contain coho salmon, chinook salmon, or steelhead, sample marking is satisfactory in those cases where the Director determines it is adequate for the plan evaluation. When sample marking has been used, all marking shall be done in advance of falling operations within the WLPZ.] [NOTE: This coho section was approved by the Board but inadvertently omitted from approval by the OAL. The Board, CDF, OAL and Barclays are correcting this error.]*

"E" To ensure retention of shade canopy filter strip properties and the maintenance of wildlife values described in 14 CCR 916.4(b) [936.4(b), 956.4(b)], a base mark shall be placed below the cut line of the residual or harvest trees within the zone and shall be done in advance of timber falling operations by an RPF or supervised designee. *[In planning watersheds determined to contain coho salmon, chinook salmon, or steelhead, tree marking must be completed prior to the preharvest inspection. Sample marking is satisfactory in those cases where the Director determines it is adequate for the plan evaluation. When sample marking has been used, all marking shall be done in advance of falling operations.] [NOTE: This coho section was approved by the Board but inadvertently omitted from approval by the OAL. The Board, CDF, OAL and Barclays are correcting this error.]*

"F" Residual or harvest tree marking within the WLPZ may be stipulated in the THP by the RPF or required by the Director in site-specific cases to ensure retention of filter strip properties or to maintain soil stability of the zone. The RPF shall state in the THP if marking was used in these zones.

"G" To protect water temperature, filter strip properties, upslope stability, and fish and wildlife values, at least 50% of the overstory and 50% of the understory canopy covering the ground and adjacent waters shall be left in a well distributed multi-storied stand composed of a diversity of species similar to that found before the start of operations. The residual overstory canopy shall be composed of at least 25% of the existing overstory conifers. Species composition may be adjusted consistent with the above standard to meet on-site conditions when agreed to in the THP by the RPF and the Director.

CALIFORNIA FOREST PRACTICE RULES

"H" At least 50% of the understory vegetation present before timber operations shall be left living and well distributed within the WLPZ to maintain soil stability. This percentage may be adjusted to meet on-site conditions when agreed to in the THP by the RPF and the Director. Unless required by the Director, this shall not be construed to prohibit broadcast burning with a project type burning permit for site preparation.

"I" To protect water temperature, filter strip properties, upslope stability, and fish and wildlife values, at least 50% of the total canopy covering the ground shall be left in a well distributed multi-storied stand configuration composed of a diversity of species similar to that found before the start of operations. The residual overstory canopy shall be composed of at least 25% of the existing overstory conifers. Due to variability in Class II watercourses these percentages and species composition may be adjusted to meet on-site conditions when agreed to by the RPF and the Director in the THP.

916.5, 936.5, 956.5 Procedures for Determining Watercourse and Lake Protection Zone Widths and Protective Measures [All Districts]

TABLE I

Procedures for Determining Watercourse and Lake Protection Zone Widths and Protective Measures¹								
Water Class Characteristics or Key Indicator Beneficial Use	1) Domestic supplies, including springs, on site and/or within 100 feet downstream of the operations area and/or		1) Fish always or seasonally present offsite within 1000 feet downstream and/or		No aquatic life present, watercourse showing evidence of being capable of sediment transport to Class I and II waters under normal high water flow conditions after completion of timber operations.		Man-made watercourses, usually downstream, established domestic, agricultural, hydroelectric supply or other beneficial use.	
	2) Fish always or seasonally present onsite, includes habitat to sustain fish migration and spawning.		2) Aquatic habitat for nonfish aquatic species.					
	3) Excludes Class III waters that are tributary to Class I waters.							
Water Class	Class I		Class II		Class III		Class IV	
Slope Class (%)	Width Feet	Protection Measure	Width Feet	Protection Measure	Width Feet	Protection Measure	Width Feet	Protection Measure
					[see 916.4(c)] [see 936.4(c)] [see 956.4(c)]		[see 916.4(c)] [see 936.4(c)] [see 956.4(c)]	
<30	75	BDG	50	BEI	See CFH		See CFI	
30-50	100	BDG	75	BEI	See CFH		See CFI	
>50	150 ²	ADG	100 ³	BEI	See CFH		See CFI	
<p>1 - See Section 916.5(e) for letter designations application to this table. 2 – Subtract 50 feet width for cable yarding operations. 3 – Subtract 25 feet width for cable yarding operations.</p>								

CALIFORNIA FOREST PRACTICE RULES

916.6, 936.6, 956.6 Alternative Watercourse and Lake Protection [All Districts]

(a) Alternative prescriptions for the protection of watercourses and lakes may be developed by the RPF or proposed by the Director on a site-specific basis provided the following conditions are complied with and the alternative prescriptions will achieve compliance with the standards set forth in 14 CCR 916.3 [936.3, 956.3] and 916.4(b) [936.4(b), 956.4(b)].

(1) The following information regarding an alternative prescription shall be included in the THP:

(A) An identification of each standard prescription which would be replaced by the alternative prescription.

(B) An identification of any beneficial uses of water or other features listed in 14 CCR 916.4(b) [936.4(b), 956.4(b)] which may be adversely affected by the replaced standard prescription and the alternative practice.

(C) An evaluation of any significant effects on such beneficial uses or features due to implementation of the alternative prescription.

(D) A clear and complete explanation and justification as to the reasons why, given site-specific technical, environmental, economic, or institutional considerations, an alternative prescription is needed. The reasons given must include at least one of the following:

(aa) Implementation of the specified standard prescriptions would not be feasible.

(bb) Implementation of the specified standard prescription(s) would not adequately prevent or reduce damage to the quality and beneficial uses of water.

(cc) Implementation of the proposed alternative prescription would provide equal or greater protection, including all proposed mitigations for the quality and beneficial uses of water and those features listed in 916.4(b) [936.4(b), 956.4(b)] than would implementation of the specified standard prescriptions.

(E) A plan for evaluating the results of the proposed alternative practice by either the plan submitter or the Director. The plan must include the criteria and procedures for evaluating and inspecting each approved alternative practice.

(2) The alternative measures stated in the plan shall be written so that they provide clear, enforceable standards for the guidance of the timber operator.

(3) Prior to beginning or continuing an operation in which alternative measures have been added to an approved THP in regard to watercourse and lake protection measures, the timber operator shall acknowledge the new specifications by signing and filing with the Director, a copy of the amended plan.

(b) The Director shall not accept for inclusion in a THP alternative watercourse and lake protection measures which do not meet the standard of subsection (a) of this section. In the event that written comments received from two or more agencies listed in 4582.6 PRC and 14 CCR 1037.3 and which participated in review of the plan, including on-the-ground inspection, lead to the conclusion that the proposed alternative does not meet the criteria of 14 CCR 916.5 [936.5, 956.5], and is therefore not consistent with rules of the Board, the Director shall reject the proposed alternative.

(c) Alternative practices stated in an approved THP shall have the same force and authority as those practices required by the standard rule.

916.7, 936.7, 956.7 Reduction of Soil Loss [All Districts]

Within the watercourse and lake protection zone adjacent to Class I and Class II waters, areas where mineral soil exceeding 800 continuous square feet in size, exposed by timber operations, shall be treated for reduction of soil loss. Treatment shall be done prior to October 15th except that such bare areas created after October 15th shall be so treated within 10 days, or as agreed to by the Director. Stabilization measures shall be included and explained in the THP or other required notices. Stabilization measures shall be selected that will prevent significant movement of soil into Class I and II waters and may include, but need not be limited to, mulching, rip-rapping, grass seeding, or chemical soil stabilizers.

(a) This section does not apply to the traveled surface of roads. Erosion control measures on road surfaces are specified in 14 CCR 923 [943, 963].

(b) Where mineral soil has been exposed by timber operations on approaches to watercourse crossings of Class I or II waters, or Class III waters if an ELZ or WLPZ is required, the disturbed area shall be stabilized to the extent necessary to prevent the discharge of soil into watercourses or lakes in amounts deleterious to the quality and beneficial uses of water.

CALIFORNIA FOREST PRACTICE RULES

(c) Where necessary to protect beneficial uses of water from timber operations, protection measures, such as seeding, mulching, or replanting, shall be specified to retain and improve the natural ability of the ground cover within the standard width of the WLPZ to filter sediment, minimize soil erosion, and stabilize banks of watercourses and lakes.

916.8, 936.8, 956.8 Sensitive Watersheds [All Districts]

The Board, at a public hearing, shall determine whether nominated planning watersheds are "sensitive" to further timber operations. Classification of a watershed as "sensitive" shall be supported by substantial evidence that a condition, or conditions, exist(s) where further timber operations within the planning watershed will create a reasonable potential to cause, or contribute to ongoing, significant adverse cumulative effect(s) on the resources identified in 916.8(a)(3) [936.8(a)(3), 956.8(a)(3)], and as set forth in Technical Rule Addendum No. 2 (14 CCR 912.9)[932.9, 952.9] and that mitigation of such significant cumulative effects requires the application of protection measures not required by the Forest Practice Rules. For all planning watersheds classified as "sensitive", the Board shall identify the specific resources which are sensitive to further timber operations and specific mitigation measures that will provide the necessary protection of the sensitive resource(s). A Board finding that a planning watershed is no longer sensitive shall be supported by substantial evidence that such conditions no longer exist. Unless and until a planning watershed(s) is classified as sensitive and any necessary rulemaking completed, the existing rules shall apply:

(a) Nomination process: The Director, local, state, or federal agencies and the public may nominate planning watersheds to the Board and shall provide evidence supporting classification of the watershed as sensitive. The nominator shall discuss the effects that further timber operations will have on the specific resources identified in 14 CCR 916.8(a)(3) [936.8(a)(3), 956.8(a)(3)] which are at risk within the nominated watershed and specify those effects not sufficiently addressed under the forest practice rules and discuss the significance of the effects in light of the condition of the resources in areas adjacent to the planning watershed. Such nominations must be accompanied by the following information, descriptions, documents, or maps as appropriate:

1. Name, approximate size and location of the watershed(s) identified by county, township and range, and name(s) of USGS topographic map(s) on which the planning watershed is found.
2. The name of the higher-order stream, if any, to which the watershed is tributary.
3. Specific resources that are significantly threatened by further timber operations on non-federal timberland in the nominated watershed, including, as appropriate, but not limited to:
 - A. Fish, aquatic organisms, aquatic habitat, or riparian habitat;
 - B. Domestic and other water supplies, water quality, other beneficial uses of water existing at the time of nomination or factors related to the stream system and channel morphology.
 - C. Downstream reservoirs, navigable channels, water diversion and transport facilities, estuaries, and harbors;
 - D. Wildlife species, or the habitat of species, listed under state or federal law as rare, threatened or endangered, candidate, or sensitive, including discussion of the habitat features threatened by timber operations;
 - E. Wildlife species with narrow geographic range, low density, low reproductive rates, and highly dependent on localized habitat features, including discussion of the habitat features threatened by timber operations and a discussion of why protective measures are required to prevent a loss of population viability.
4. Natural or management-induced conditions present in the watershed which pose a significant threat to the resources identified in 14 CCR 916.8(a)(3) [936.8(a)(3) and 956.8(a)(3)], above, including, as appropriate, but not limited to:
 - A. Steep slopes and easily destabilized soils;
 - B. Continuing landslide or soil erosion problems related to past or ongoing land-use activities;
 - C. Extensive ground disturbance, particularly associated with roads, skid trails, landings, and watercourse crossings;
 - D. Accelerated aggradation, streambank erosion, and channel scouring;
 - E. Changes in the habitat or condition of wildlife species identified in 14 CCR 916.8(a)(3) [936.8(a)(3) and 956.8(a)(3)], above.

CALIFORNIA FOREST PRACTICE RULES

F. Accelerated rates of proposed road construction or timber harvesting within a watershed or near streams or springs.

5. Approved Habitat Conservation Plans or other documents approved or under review by public agencies within the nominated watershed which provide for maintenance or improvement over time of management induced conditions within or adjacent to the planning watershed or forest district.

6. Suggested, feasible mitigation measures needed, in addition to current forest practice rules, to provide adequate protection for resources identified in 14 CCR 916.8(a)(3) [936.8(a)(3) and 956.8(a)(3)], above, and to mitigate or avoid new or continuing significant cumulative effects related to timber operations, including, but not limited to, restoration or rehabilitation of degraded resources within any portion of the proposed sensitive watershed.

7. Other information about the watershed that may assist the Board to evaluate the nomination.

8. Literature citations, expert written opinion, and other relevant sources of information and, where possible, copies of information used to complete the nomination.

9. A list of names and mailing addresses of the following:

A. Landowners of 40 acres or more of lands zoned for timber production in the planning watershed;

B. Public water purveyors and known private purveyors within the planning watershed;

C. Commonly known watershed associations within the planning watershed;

D. Commonly known neighborhood or community associations within the planning watershed;

E. Chairman, county board of supervisors;

F. Chairman, county planning commission;

G. Local manager for any public agency having custodial responsibility for timberlands within the planning watershed; and

H. District or local representatives for review team agencies.

10. A draft notice for newspaper publication containing the information in (a)(1)-(3), a statement that a public hearing will be scheduled before the Board within 60 days of Board receipt of a nomination forwarded by the committee, and a statement that further information can be obtained from the local Department Ranger Unit Headquarters.

(b) Notice Process: The Board shall mail notice of the nominated watershed, as provided in (a)10, to the addresses of parties described in 9 A-H and shall publish the provided notice one time in a newspaper with general circulation in the county containing the planning watershed. Such notice shall be provided following a determination that information contained in the nomination meets the requirements of 14 CCR 916.8(a) [936.8(a) and 956.8(a)], above.

(c) Screening Process: Before consideration by the Board, nominations shall be screened for compliance with the informational requirements by a nominations review committee, which may consist of the appropriate District Technical Advisory Committee or other Board Committee, as determined by the Board. The nominations review committee shall consult with CDF, the appropriate Regional Water Quality Control Board, the Department of Fish and Game, the Division of Mines and Geology, and other(s) as deemed necessary to determine whether the nomination is supported by substantial evidence. The nominations review committee shall then forward a recommendation for approval or denial of the nomination to the Board within 120 days of the date of receipt by the committee, or such longer time provided by the Board. The nominations review committee shall describe its specific reason(s) for recommending approval or denial of the nomination. In the event that the committee forwards a recommendation for approval, it shall describe the substantial evidence which supports nomination, including specific reasons why the current forest practice rules are inadequate to protect the specific resources at risk and shall provide the following information:

1. A list of which resource is threatened and by which timber operations;

2. If possible, performance standard(s) for timber operations that will avoid or mitigate new or continuing significant cumulative effects;

3. Additional information that is needed for evaluating the impacts of proposed timber operations and is to be included in harvesting plans submitted in the planning watershed;

4. On-site mitigation measures in addition to the current forest practice rules, which can be required by the Director to mitigate the impacts of timber operations within the watershed;

CALIFORNIA FOREST PRACTICE RULES

5. Offsite mitigation measures that can be applied within or outside of the sensitive watershed area to offset adverse on-site impacts of timber operations. If such mitigation measures are proposed to protect the resource discussed in subdivision (a)(3)(A) and (B), they must occur in the same drainage. Such measures may include, but are not limited to, voluntary mitigation agreements among ownerships.

6. If needed, recommended alternatives to evaluate the implementation and effectiveness of mitigations required under this section.

7. Exemptions for ownerships, emergencies, or land-use classifications that are different than those provided in the current forest practice regulations and that may be applied in the watershed.

(d) Public hearing Process: The Board shall consider the recommendations of the nominations review committee at a public hearing on classification of the planning watershed, which will be held within 60 days of receipt from the committee. The watershed nomination and recommendations of the committee will be made available to the public between the date of receipt by the Board and the public hearing.

Recommendations adopted by the Board which have the effect of a regulation shall be processed in accordance with the Administrative Procedures Act (Section 11340. et seq. Gov. Code).

916.9, 936.9, 956.9 Protection and Restoration in Watersheds with Threatened or Impaired Values [All Districts]

In addition to all other district Forest Practice Rules, the following requirements shall apply in any planning watershed with threatened or impaired values:

(a) GOAL - Every timber operation shall be planned and conducted to prevent deleterious interference with the watershed conditions that primarily limit the values set forth in 14 CCR 916.2 [936.2, 956.2](a) (e.g., sediment load increase where sediment is a primary limiting factor; thermal load increase where water temperature is a primary limiting factor; loss of instream large woody debris or recruitment potential where lack of this value is a primary limiting factor; substantial increase in peak flows or large flood frequency where peak flows or large flood frequency are primary limiting factors). To achieve this goal, every timber operation shall be planned and conducted to meet the following objectives where they affect a primary limiting factor:

(1) Comply with the terms of a Total Maximum Daily Load (TMDL) that has been adopted to address factors that may be affected by timber operations if a TMDL has been adopted, or not result in any measurable sediment load increase to a watercourse system or lake.

(2) Not result in any measurable decrease in the stability of a watercourse channel or of a watercourse or lake bank.

(3) Not result in any measurable blockage of any aquatic migratory routes for anadromous salmonids or listed species.

(4) Not result in any measurable stream flow reductions during critical low water periods except as part of an approved water drafting plan pursuant to 14 CCR 916.9(r) [936.9(r), 956.9(r)].

(5) Consistent with the requirements of 14 CCR § 916.9(i), 14 CCR § 936.9(i), or 14 CCR § 956.9(i); protect, maintain, and restore trees (especially conifers), snags, or downed large woody debris that currently, or may in the foreseeable future, provide large woody debris recruitment needed for instream habitat structure and fluvial geomorphic functions.

(6) Consistent with the requirements of 14 CCR § 916.9(g), 14 CCR § 936.9(g), or 14 CCR § 956.9(g); protect, maintain, and restore the quality and quantity of vegetative canopy needed to: (A) provide shade to the watercourse or lake, (B) minimize daily and seasonal temperature fluctuations, (C) maintain daily and seasonal water temperatures within the preferred range for anadromous salmonids or listed species where they are present or could be restored, and (D) provide hiding cover and a food base where needed.

(7) Result in no substantial increases in peak flows or large flood frequency.

(b) Pre-plan adverse cumulative watershed effects on the populations and habitat of anadromous salmonids shall be considered. The plan shall specifically acknowledge or refute that such effects exist. Where appropriate, the plan shall set forth measures to effectively reduce such effects.

(c) Any timber operation or silvicultural prescription within 150 feet of any Class I watercourse or lake transition line or 100 feet of any Class II watercourse or lake transition line shall have protection, maintenance, or restoration of the beneficial uses of water or the populations and habitat of anadromous salmonids or listed aquatic or riparian-associated species as significant objectives.

CALIFORNIA FOREST PRACTICE RULES

Additionally, for evenaged regeneration methods and rehabilitation with the same effects as a clearcut that are adjacent to a WLPZ, a special operating zone shall retain understory and mid-canopy conifers and hardwoods. These trees shall be protected during falling, yarding and site preparation to the extent feasible. If trees that are retained within this zone are knocked down during operations, that portion of the trees that is greater than 6" in diameter shall remain within the zone as Large Woody Debris. The zone shall be 25 feet above Class I WLPZs with slopes 0-30% and 50 feet above Class I WLPZs with slopes > 30%.

(d) (1) The plan shall fully describe: (A) the type and location of each measure needed to fully offset sediment loading, thermal loading, and potential significant adverse watershed effects from the proposed timber operations, and (B) the person(s) responsible for the implementation of each measure, if other than the timber operator.

(2) In proposing, reviewing, and approving such measures, preference shall be given to the following: (A) measures that are both onsite (i.e., on or near the plan area) and in-kind (i.e., erosion control measures where sediment is the problem), and (B) sites that are located to maximize the benefits to the impacted portion of a watercourse or lake. Out-of-kind measures (i.e., improving shade where sediment is the problem) shall not be approved as meeting the requirements of this subsection.

(e) Channel zone requirements

(1) There shall be no timber operations within the channel zone with the following exceptions:

(A) timber harvesting that is directed to improve salmonid habitat through the limited use of the selection or commercial thinning silvicultural methods with review and comment by DFG.

(B) timber harvesting necessary for the construction or reconstruction of approved watercourse crossings.

(C) timber harvesting necessary for the protection of public health and safety.

(D) to allow for full suspension cable yarding when necessary to transport logs through the channel zone.

(E) Class III watercourses where exclusion of timber operations is not needed for protection of listed salmonids.

(2) In all instances where trees are proposed to be felled within the channel zone, a base mark shall be placed below the cut line of the harvest trees within the zone. Such marking shall be completed by the RPF that prepared the plan prior to the preharvest inspection.

(f) The minimum WLPZ width for Class I waters shall be 150 feet from the watercourse or lake transition line. Where a proposed THP is located within the Sacramento or San Joaquin river drainages, and the Director, DFG, and the National Marine Fisheries Service concur; the RPF may explain and justify other WLPZ widths on areas where even aged regeneration methods, seed tree removal, shelterwood removal, alternative prescriptions, or rehabilitation will not be utilized adjacent to watercourse and lake protection zones and where slopes are less than 30%.

(g) Within a WLPZ for Class I waters, at least 85 percent overstory canopy shall be retained within 75 feet of the watercourse or lake transition line, and at least 65 percent overstory canopy within the remainder of the WLPZ. The overstory canopy must be composed of at least 25% overstory conifer canopy post-harvest. Where a proposed THP is located within the Sacramento or San Joaquin river drainages, and the Director, DFG, and the National Marine Fisheries Service concur; the RPF may explain and justify other canopy retention standards on areas where even aged regeneration methods, seed tree removal, shelterwood removal, alternative prescriptions, or rehabilitation will not be utilized adjacent to watercourse and lake protection zones and where slopes are less than 30%.

Harvesting of hardwoods shall only occur for the purpose of enabling conifer regeneration.

(h) For Class I waters, any plan involving timber operations within the WLPZ shall contain the following information:

(1) A clear and enforceable specification of how any disturbance or log or tree cutting and removal within the Class I WLPZ shall be carried out to conform with 14 CCR 916.2 [936.2, 956.2](a) and 916.9 [936.9, 956.9](a).

(2) A description of all existing permanent crossings of Class I waters by logging roads and clear specification regarding how these crossings are to be modified, used, and treated to minimize risks, giving special attention to allowing fish to pass both upstream and downstream during all life stages.

(3) Clear and enforceable specifications for construction and operation of any new crossing of Class I waters to prevent direct harm, habitat degradation, water velocity increase, hindrance of fish passage, or

CALIFORNIA FOREST PRACTICE RULES

other potential impairment of beneficial uses of water.

(i) Recruitment of large woody debris for aquatic habitat in Class I anadromous fish-bearing or restorable waters shall be ensured by retaining the ten largest dbh conifers (live or dead) per 330 feet of stream channel length that are the most conducive to recruitment to provide for the beneficial functions of riparian zones. The retained conifers shall be selected from within the THP area that lies within 50 feet of the watercourse transition line. Where the THP boundary is an ownership boundary, a class I watercourse, and the WLPZ on both sides of the watercourse currently meets the stocking standards listed under 14 CCR 912.7[932.7,952.7](b)(2); the five (5) largest dbh conifers (live or dead) per 330 feet of stream channel length that are the most conducive to recruitment to provide for the beneficial functions of riparian zones within the THP area shall be retained within 50 feet of the watercourse transition line.

The RPF may propose alternatives to substitute smaller diameter trees, trees that are more than 50 feet from the watercourse transition line, or other alternatives on a site specific basis. The RPF must explain and justify in the THP why the proposed alternative is more conducive to current and long-term Large Woody Debris recruitment, shading, bank stability, and the beneficial functions of riparian zones.

(j) Where an inner gorge extends beyond a Class I WLPZ and slopes are greater than 55%, a special management zone shall be established where the use of evenaged regeneration methods is prohibited. This zone shall extend upslope to the first major break-in-slope to less than 55% for a distance of 100 feet or more, or 300 feet as measured from the watercourse or lake transition line, which ever is less. All operations on slopes exceeding 65% within an inner gorge of a Class I or II watercourse shall be reviewed by a Registered Geologist prior to plan approval, regardless of whether they are proposed within a WLPZ or outside of a WLPZ.

(k) From October 15 to May 1, the following shall apply: (1) no timber operations shall take place unless the approved plan incorporates a complete winter period operating plan pursuant to 14 CCR 914.7(a) [934.7(a), 954.7(a)], (2) unless the winter period operating plan proposes operations during an extended period with low antecedent soil wetness, no tractor roads shall be constructed, reconstructed, or used on slopes that are over 40 percent and within 200 feet of a Class I, II, or III watercourse, as measured from the watercourse or lake transition line, and (3) operation of trucks and heavy equipment on roads and landings shall be limited to those with a stable operating surface.

(l) Construction or reconstruction of logging roads, tractor roads, or landings shall not take place during the winter period unless the approved plan incorporates a complete winter period operating plan pursuant to 14 CCR 914.7(a) [934.7(a), 954.7(a)] that specifically address such road construction. Use of logging roads, tractor roads, or landings shall not take place at any location where saturated soil conditions exist, where a stable logging road or landing operating surface does not exist, or when visibly turbid water from the road, landing, or skid trail surface or inside ditch may reach a watercourse or lake. Grading to obtain a drier running surface more than one time before reincorporation of any resulting berms back into the road surface is prohibited.

(m) All tractor roads shall have drainage and/or drainage collection and storage facilities installed as soon as practical following yarding and prior to either (1) the start of any rain which causes overland flow across or along the disturbed surface within a WLPZ or within any ELZ or EEZ designated for watercourse or lake protection, or (2) any day with a National Weather Service forecast of a chance of rain of 30 percent or more, a flash flood warning, or a flash flood watch.

(n) Within the WLPZ, and within any ELZ or EEZ designated for watercourse or lake protection, treatments to stabilize soils, minimize soil erosion, and prevent the discharge of sediment into waters in amounts deleterious to aquatic species or the quality and beneficial uses of water, or that threaten to violate applicable water quality requirements, shall be applied in accordance with the following standards:

(1) The following requirements shall apply to all such treatments.

(A) They shall be described in the plan.

(B) For areas disturbed from May 1 through October 15, treatment shall be completed prior to the start of any rain that causes overland flow across or along the disturbed surface.

(C) For areas disturbed from October 16 through April 30, treatment shall be completed prior to any day for which a chance of rain of 30 percent or greater is forecast by the National Weather Service or within 10 days, whichever is earlier.

(2) The traveled surface of logging roads shall be treated to prevent waterborne transport of sediment and concentration of runoff that results from timber operations.

CALIFORNIA FOREST PRACTICE RULES

(3) The treatment for other disturbed areas, including: (A) areas exceeding 100 contiguous square feet where timber operations have exposed bare soil, (B) approaches to tractor road watercourse crossings between the drainage facilities closest to the crossing, (C) road cut banks and fills, and (D) any other area of disturbed soil that threatens to discharge sediment into waters in amounts deleterious to the quality and beneficial uses of water, may include, but need not be limited to, mulching, rip-rapping, grass seeding, or chemical soil stabilizers. Where straw, mulch, or slash is used, the minimum coverage shall be 90%, and any treated area that has been subject to reuse or has less than 90% surface cover shall be treated again prior to the end of timber operations. The RPF may propose alternative treatments that will achieve the same level of erosion control and sediment discharge prevention.

(4) Where the undisturbed natural ground cover cannot effectively protect beneficial uses of water from timber operations, the ground shall be treated by measures including, but not limited to, seeding, mulching, or replanting, in order to retain and improve its natural ability to filter sediment, minimize soil erosion, and stabilize banks of watercourses and lakes.

(o) As part of the plan, the RPF shall identify active erosion sites in the logging area, assess them to determine which sites pose significant risks to the beneficial uses of water, assess them to determine whether feasible remedies exist, and address in the plan feasible remediation for all sites that pose significant risk to the beneficial uses of water.

(p) The erosion control maintenance period on permanent and seasonal roads and associated landings that are not abandoned in accordance with 14 CCR 923.8 [943.8, 963.8] shall be three years.

(q) Site preparation activities shall be designed to prevent soil disturbance within, and minimize soil movement into, the channels of watercourses. Prior to any broadcast burning, burning prescriptions shall be designed to prevent loss of large woody debris in watercourses, and vegetation and duff within a WLPZ, or within any ELZ or EEZ designated for watercourse or lake protection. No ignition is to occur within any WLPZ, or within any ELZ or EEZ designated for watercourse or lake protection. When burning prescriptions are proposed, the measures or burning restrictions which are intended to accomplish this goal shall be stated in the plan and included in any required burning permit. This information shall be provided in addition to the information required under 14 CCR 915.4 [935.4, 955.4].

(r) Water drafting for timber operations from within a channel zone of a natural watercourse or from a lake shall conform with the following standards:

(1) The RPF shall incorporate into the THP:

(A) a description and map of proposed water drafting locations,

(B) the watercourse or lake classification, and

(C) the general drafting location use parameters (i.e., yearly timing, estimated total volume needed, estimated total uptake rate and filling time, and associated water drafting activities from other THPs).

(2) On Class I and Class II streams where the RPF has estimated that:

(A) bypass flows are less than 2 cubic feet per second, or

(B) pool volume at the water drafting site would be reduced by 10%, or

(C) diversion rate exceeds 350 gallons per minute, or

(D) diversion rate exceeds 10% of the above surface flow;

no water drafting shall occur unless the RPF prepares a water drafting plan to be reviewed by DFG and approved by the Director.

The water drafting plan shall include, but not be limited to:

1. disclosure of estimated percent streamflow reduction and duration of reduction,

2. discussion of the effects of single pumping operations, or multiple pumping operations at the same location,

3. proposed alternatives and discussion to prevent adverse effects (e.g. reduction in hose diameter, reduction in total intake at one location, described allowances for recharge time, and alternative water drafting locations),

4. conditions for operators to include an operations log kept on the water truck containing the following information: Date, Time, Pump Rate, Filling Time, Screen Cleaned, Screen Conditions, and Bypass flow observations,

5. a statement by the RPF for a pre-operations field review with the operator to discuss the conditions in the water drafting plan.

CALIFORNIA FOREST PRACTICE RULES

(3) Intakes shall be screened in Class I and Class II waters. Screens shall be designed to prevent the entrainment or impingement of all life stages of fish or amphibians. Screen specifications shall be included in the plan.

(4) Approaches to drafting locations within a WLPZ shall be surfaced with rock or other suitable material to avoid generation of sediment.

(s) No timber operations are allowed in a WLPZ, or within any ELZ or EEZ designated for watercourse or lake protection, under emergency notices or exemption notices except for hauling on existing roads, road maintenance, and operations conducted for public safety, construction or reconstruction of approved watercourse crossings, temporary crossings of dry Class III watercourses which do not require a "Streambed Alteration Agreement" under the Fish and Game Code or forest conditions requiring harvesting that is approved by a letter of concurrence from DFG and the National Marine Fisheries Service.

(t) No salvage logging is allowed in a WLPZ without an approved HCP, an SYP, or an approved plan that contains a section that sets forth objectives, goals, and measurable results for streamside salvage operations.

(u) Nonstandard practices (i.e., waivers, exceptions, in-lieu practices, and alternative practices) shall comply with the goal set forth in subsection (a) above as well as with the other requirements set forth in the rules.

(v) The Director may approve alternatives provided the alternative practice will achieve the goal of this section. The Director shall not accept for inclusion in a plan any alternative practice as described in this section where two or more agencies listed in 4582.6 of the PRC and 14 CCR 1037.3 have submitted written comments which lead to the Director's conclusion that the proposed alternative will not meet the goal of this section and the agency(ies) participated in the review of the plan, including an on-the-ground inspection.

(w) Other measures that would effectively achieve the goal set forth in 14 CCR 916.9(a) [936.9(a), 956.9(a)] may be approved in accordance with 14 CCR 916.6 [936.6, 956.6].

(x) The provisions of 14 CCR 916.9 [936.9, 956.9] shall not apply to a plan that is subject to an incidental take permit based upon an approved Habitat Conservation Plan that addresses anadromous salmonid protection.

(y) This section shall expire on December 31, 2002.

916.10, 936.10, 956.10 Domestic Water Supply Protection [All Districts]

(a) When proposed timber operations may threaten to degrade a domestic water supply the Director shall evaluate any mitigations recommended prior to the close of the public comment period (PRC 4582.7) and shall require the adoption of those practices which are feasible and necessary to protect the quality and beneficial use of the supply.

(b) The Director may require a post-harvest evaluation of the effectiveness of the mitigations and practices designed to protect the domestic water supply as a condition of plan approval. The Director shall require an evaluation at the request of the California Regional Water Quality Control Board, or any affected water purveyor, if the necessity for the evaluation is supported by substantial evidence in the record. This evidence may include, but is not limited to, potential land failures, accelerated rate of road construction or harvesting within a watershed, concentration or intensity of harvesting activity near streams or springs. The design and implementation of the evaluation shall be done in consultation with the Director, appropriate RWQCB, and THP submitter, and the sufficiency of the information requested by the Director shall be judged in light of reasonableness and practicality.

916.11, 936.11, 956.11 Effectiveness and Implementation Monitoring [All Districts]

(a) Where timber operations will be conducted within a WLPZ, the Director may require a post-harvest evaluation of the effectiveness of the mitigations and practices designed to protect the watercourse(s) or lake(s) as a condition of plan approval. The Director shall require such an evaluation if the necessity for the evaluation is supported by substantial evidence in the record. This evidence may include, but is not limited to, potential land failures, accelerated rate of road construction or harvesting within a watershed, concentration or intensity of harvesting activity near watercourses, and potential for accelerated windthrow. The design and implementation of the evaluation shall be done in consultation with the Director, the RWQCB or DFG, and THP submitter, and the sufficiency of the information requested by the Director shall be judged in light of reasonableness and practicality. The evaluation may utilize procedures including, but not limited, to:

CALIFORNIA FOREST PRACTICE RULES

(1) Procedures for effectiveness and implementation monitoring.

(2) Existing landowner monitoring programs, or

(3) Photographic monitoring

(b) This section shall expire on December 31, 2002.

916.12, 936.12, 956.12 Section 303(d) Listed Watersheds [All Districts]

For any planning watershed in which timber operations could contribute to the pollutants or stressors which have been identified as limiting water quality in a water body listed pursuant to 303(d) Federal Clean Water Act, the following shall apply:

(a) The Department shall, in collaboration with the appropriate RWQCB and SWRCB, prioritize watersheds in which the following will be done: 1) conduct or participate in any further assessment or analysis of the watershed that may be needed, 2) participate in the development of Total Maximum Daily Load (TMDL) problem assessment, source assessment, or load allocations related to timber operations, and 3) if existing rules are deemed not to be sufficient, develop recommendations for watershed-specific silvicultural implementation, enforcement and monitoring practices to be applied by the Department.

(b) The Department shall prepare a report setting forth the Department's findings and recommendations from the activities identified pursuant to (a) above. The report shall be submitted to the Board and the appropriate RWQCB. The report shall be made available to the public upon request and placed on the Boards' website for a 90-day period.

(c) Where the Department has recommended that the adoption of watershed specific rules is needed, the Board shall consider that recommendation as a proposal for rulemaking under the Administrative Procedures Act (Section 11340 et. seq. Gov Code) and shall begin that process within 180 days following receipt of that report.

(d) These watershed specific rules shall be developed in collaboration with the appropriate RWQCB, the landowner(s) or designee with land in the planning watershed, and other persons or groups within the watershed, and may also be incorporated into a TMDL implementation plan.

(e) The watershed specific rules shall remain in effect until the water body has been removed from the 303(d) list, or that the Board finds, after consulting with the appropriate RWQCB, that timber operations are no longer a significant source of the pollutant or stressor that limits water quality in the listed water body.

(f) This section shall expire on December 31, 2002.

Article 7 Hazard Reduction

917, 937, 957 Hazard Reduction [All Districts]

This article shall provide standards for the treatment of snags and logging slash in order to reduce fire and pest safety hazards in the logging area, to protect such area from potential insect and disease attack, and to prepare the area for natural or artificial reforestation while retaining wildlife habitat.

917.2, 937.2, 957.2 Treatment of Slash to Reduce Fire Hazard [All Districts]

Except in the Southern Subdistrict of the Coast Forest District and Coastal Commission Special Treatment Areas of the Coast Forest District, the following standards shall apply to the treatment of slash created by timber operations within the plan area and on roads adjacent to the plan area, but excluding appurtenant roads. Lopping for fire hazard reduction is defined in 14 CCR 895.1.

(a) Slash to be treated by piling and burning shall be treated not later than April 1 of the year following its creation, or within 30 days following climatic access, or as justified in the plan.

(b) Within 100 ft. of the edge of the traveled surface of public roads, and within 50 ft. of the edge of the traveled surface of permanent private roads open for public use where permission to pass is not required, slash created and trees knocked down by road construction or timber operations shall be treated by lopping for fire hazard reduction, piling and burning, chipping, burying or removal from the zone.

(c) All woody debris created by timber operations greater than one inch but less than eight inches in diameter within 100 ft. of permanently located structures maintained for human habitation shall be removed or piled and burned; all slash created between 100-200 ft. of permanently located structures maintained for human habitation shall be lopped for fire hazard reduction, removed, chipped or piled and burned; lopping may be required between 200-500 ft. where unusual fire risk or hazard exist as determined by the Director or

CALIFORNIA FOREST PRACTICE RULES

the RPF.

(d) An alternative to treating slash along roads and within 200 ft. of structures may be approved by the Director when the RPF explains and justifies in the plan how equal fire protection will be provided. The alternative shall include a description of the alternate treatment(s) and the portion(s) of the plan area in which they will be utilized. In proposing alternate slash treatments the RPF shall consider the estimated amount and distribution of slash to be created by the operation, type of remaining vegetation, topography, climate, and degree of public exposure fire history.

917.3 Prescribed Broadcast Burning of Slash [Coast]

Outside the Southern Subdistrict, broadcast burning may be prescribed for slash treatment subject to the following conditions:

- (a) It may occur in Zone A, as described in PRC 4423, subject to a project-type burning permit;
- (b) It may occur in Zone B, as described in PRC 4423, without a burning permit from December 1 through March 31, unless a permit is required pursuant to paragraph (e), or subject to the provisions of a project-type burning permit between April 1 and December 1;
- (c) It may occur within cleared firebreaks of not less than 10 ft. (3.05 m) in width;
- (d) Use of the broadcast burning prescription in the Watercourse and Lake Protection Zone for Class I, and II waters, is prohibited. Where necessary to protect downstream beneficial uses, the Director may prohibit burning prescriptions in Class III watercourses.
- (e) Exceptions to requirements (b), (c), and (d) above may be granted to any time of year provided a project-type burning permit is obtained prior to burning and the terms of the permit are adhered to while burning.

937.3 Prescribed Broadcast Burning of Slash [Northern]

Broadcast burning may be prescribed for slash treatment subject to the following conditions:

- (a) Such burning shall be done only after the first heavy fall rains and shall be completed before April 1;
- (b) It may occur within cleared firebreaks of not less than 10 ft. (3.05 m) in width;
- (c) Use of the broadcast burning prescription of the Stream and Lake Protection Zone for Class I, and lass II, is prohibited. Where necessary to protect downstream beneficial uses, the Director may prohibit burning prescriptions in Class III watercourses;
- (d) Exceptions to requirements (a), (b) and (c) above may be granted provided a project-type burning permit is obtained prior to burning and the terms of the permit are adhered to while burning.

957.3 Prescribed Broadcast Burning of Slash [Southern]

Outside the High Use Subdistrict, broadcast burning may be prescribed for slash treatment subject to the following conditions:

- (a) Such burning shall be done only after the first heavy fall rains and shall be completed before April 1;
- (b) It may occur within cleared firebreaks of not less than 10 ft. (3.05 m) in width;
- (c) Use of the broadcast burning prescription of the Stream and Lake Protection Zone for Class I, and lass II, is prohibited. Where necessary to protect downstream beneficial uses, the Director may prohibit burning prescriptions in Class III watercourses;
- (d) Exceptions to requirements (a), (b) and (c) above may be granted provided a project-type burning permit is obtained prior to burning and the terms of the permit are adhered to while burning.

917.4 Treatment of Logging Slash in the Southern Subdistrict [Coast]

To reduce fire hazards within the Southern Subdistrict of the Coast Forest District, treatment of slash created by timber operations shall be done in addition to requirements of 14 CCR 917.2 as follows:

- (a) To provide more efficient firebreaks the areas within 50 feet (15.24 m) of the edge of an public roads shall be kept free of slash greater than 1 in. (2.5 cm) in diameter. Slash between 50 ft. (15.24 m) and 100 ft. (30.48 m) of the edge of said roads and slash within 200 ft. (60.96 m) of all permanently located structures currently maintained for human habitation shall be treated by piling and burning, chipping, burying, removal, or lopping to within 12 in. (30.5 cm) above the ground not later than April 1 of the year following its

CALIFORNIA FOREST PRACTICE RULES

creation. Distances shall be measured along the surface of the ground. Timber operations shall not cause a violation of PRC 4291.

(b) Concentrations of slash created by the current operation around logging landings or located within the logging area excluding those areas substantially covered with logs on the ground, shall be crushed, chipped, spread, piled and burned, or otherwise treated no later than April 1st of the following year following their creation.

(c) Slash created by the current timber operation within and adjacent to the logging area, excluding those areas substantially covered with logs on the ground, shall be lopped over the entire logging area by April 1st of the year following the creation of the slash. Slash created by the current operations along roads not in the logging area shall be lopped concurrently with its creation.

(d) Use of the broadcast burning prescription for slash is prohibited in the Southern Subdistrict of the Coast Forest District.

957.4 Treatment of Logging Slash in the High Use Subdistrict [Southern]

Slash in the High Use Subdistrict shall be treated as follows:

(a) Throughout the logging area, all limbs shall be lopped from the unutilized portions of felled trees and all other trees felled or pushed over during timber operations. This lopping shall be done concurrently with the timber operations and scattered so that no limb or stem larger than 4 in. (10.2 cm) in diameter will be covered with slash and no slash shall generally be more than 24 in. (61.0 cm) above the ground.

(b) Slash shall be treated by chipping, piling and burning, burying, or removal on the following areas within all distances measured along the surface to the ground.

(1) Within a distance of 200 feet (60.96 m) of structures used for habitation;

(2) Within 200 feet (60.96 m) of the edge of any road accessible to the public;

(3) Within 100 feet (30.48 m) of trails established for and used by the public;

(4) Within a distance of 200 feet (60.96 m) of areas established for and used by the public for picnicking or camping.

(c) Slash treatment must be done concurrently with logging or road construction. On areas logged between April 1st and October 1st, if the slash is not disposed of in some other manner, it shall be piled progressively for burning. Piling shall not take place earlier than the 15th day nor later than the 45th day following cutting. Between October 1st and April 1st of the following year, the slash to be burned shall be progressively piled and burned not later than 30 days following cutting.

(d) Prescribed broadcast burning of slash is allowed in the High Use Subdistrict when a permit is obtained from the Director or his representative.

917.5, 937.5, 957.5 Burning of Piles and Concentrations of Slash [All Districts with minor variances]

When the option of burning piles or concentrations of slash is chosen to meet the slash treatment requirements as specified in these rules, such burning shall be done as follows:

(a) Piles and concentrations shall be sufficiently free of soil and other noncombustible material for effective burning.

(b) The piles and concentrations shall be burned at a safe time during the first wet fall or winter weather or other safe period following piling and according to laws and regulations. Piles and concentrations that fail to burn sufficiently to remove the fire hazard shall be further treated to eliminate that hazard. All necessary precautions shall be taken to confine such burning to the piled slash.

917.6, 937.6, 957.6 Notification of Burning [All Districts]

The local representative of the Director shall be notified in advance of the time and place of any burning of logging slash. Any burning shall be done in the manner provided by Law.

917.7, 937.7, 957.7 Protection of Residual Trees [All Districts]

Slash burning operations and fire hazard abatement operations shall be conducted in a manner which will not damage residual trees and reproduction to the extent that they will not qualify to meet the silvicultural and stocking requirements of the rules.

CALIFORNIA FOREST PRACTICE RULES

[NOTE: Barclays official record for sections 917.9 – 917.11, 937.9 – 937.11, and 957.9 – 957.11 were incorrectly changed in 1991, Register 92 Number 13, and should read as follows. This correct language has always been printed by CDF. The Board, CDF, Barclays and OAL are working to correct this.]

917.9, 937.9, 957.9 Prevention Practices. [All Districts]

Timber operations shall be conducted so as to minimize the build-up of destructive insect populations or the spread of forest diseases. To achieve this goal the following shall occur:

(a) Where THPs are in areas where the Board has declared a zone of infestation or infection pursuant to PRC sections 4712 - 4718, the RPF shall identify feasible measures being taken to mitigate adverse infestation or infection impacts from the timber operation.

(b) Where significant adverse insect or disease build-ups are identified by the RPF preparing the plan or the Director on an area to be harvested under a THP, the plan shall include feasible measures to address the problem.

(c) The Board has determined that insects breeding in pine logging slash can be a significant problem if they are not managed. Board of Forestry Technical Rule Addendum Number 3 describes the considerations that the RPF preparing a THP shall use in developing alternatives for treating pine brood material. The addendum also describes methods of treating pine brood material that may be used to meet the objectives of this rule. The RPF may propose or the Director may require hazard reduction treatments to mitigate significant adverse impacts of insects breeding in pine brood material at any time during the life of a THP.

BOARD OF FORESTRY TECHNICAL RULE ADDENDUM NO. 3 BROOD MATERIAL

A. Hazard Determination -

- Tree mortality and top killing result when Ips beetle populations reproduce and increase in pine brood material 1/ and then leave this material and attack pines in the residual stand. Hazard increases with the amount of pine brood material present.

- Any suitable breeding material, including pine logs from recently felled trees, represents a hazard as long as it remains on site long enough for the beetles to complete a life cycle in it. During suitable weather, the life cycle may be as short as five weeks. Piling of brood material is more hazardous than leaving it spread-out on the ground.

- Timing of brood material production may influence hazard. Hazard is presumed to be highest when pine brood material is produced from February through June and moderate when produced at other times of the year. At no time is hazard presumed to be low. In some parts of the Southern Forest District, hazard is presumed to be high year round, regardless of when the brood material was produced.

- Age, size, and species of residual trees influence hazard. Young pole size stands of pine are most susceptible to damage. Tree species other than pine are not damaged by insects that breed in pine brood material. Brood material from tree species other than pine generally does not contribute to the build-up of damaging beetle populations.

- Low vigor residual trees are at greatest risk. Historically, drought stressed, suppressed, and overstocked stands have been identified as high risk. Off-site, diseased, damaged, and overmature trees are also at risk.

- If damaging insect populations are high, hazard will be greater. High beetle populations have the potential to damage more than just low vigor trees. Chronic pine mortality in the area should be evaluated to determine if high beetle populations are present. An established Zone of Infestation for pine bark beetles implies that conditions are appropriate for the build-up of beetle populations.

- Potential for the spread of damaging insects to adjacent ownerships should be considered. The closer the ownership, the greater the risk. Generally, ownerships beyond one quarter of a mile will have little or no risk.

- Value of residual trees should be considered. How much loss to residuals is acceptable?

B. Hazard Reduction Treatment Alternatives -

Any treatment to reduce hazard should apply to the entire area where a hazard has been determined to exist, including the area where lopping for fire hazard reduction has been used. Treatment alternatives include modification of the brood material so that it is less suitable as a breeding site for beetles or methods to reduce

CALIFORNIA FOREST PRACTICE RULES

beetle populations that have developed. Specific Treatment Alternatives applied to pine brood material are as follows:

(1) The following treatments are acceptable provided they are completed before insect broods emerge from infested material. During weather that is suitable for brood development, a five week window is the maximum time that should elapse between creation of brood material and its treatment by one of the following methods: brood material can be removed from the site for processing or disposal; if left on-site, it can be piled and burned, chipped, debarked, treated with an appropriate pesticide, or piled and covered with clear plastic. If brood material is piled and covered, the plastic used must be a minimum of 6 mil thick; piles must be completely sealed by the plastic so that there are no openings to the outside and remain covered for 6 months (or 4 months if at least 2 summer months are included).

(2) The following treatment is acceptable, provided it is completed as soon after brood material creation as is practical, but not later than one week. Lop all branches from the sides and tops of those portions of main stems which are 3" or more in diameter. Branches shall be scattered so that stems have maximum exposure to solar radiation. Do not pile brood material. Lopped stems could also be cut into short segments to decrease drying time and further reduce hazard.

(3) Burying brood material will prevent it from being colonized by beetles, but may not prevent emergence of the beetles. Therefore, it must be buried before becoming infested. During suitable weather, brood material must be buried concurrent with its creation. "Suitable" weather depends upon location. In areas that receive snowfall, suitable weather generally exists from April 15-October 15. In other areas, suitable weather exists from March 1-November 30.

917.10 [sic], 937.10, 957.10 Locating and Reporting [All Districts]

Timber operators, timber owners and RPFs, if any, employed on the operation, shall assist the State in determining the location of insect and disease outbreaks, and report such outbreaks to the Director or a representative of the Director.

Article 8 Fire Protection

918, 938, 958 Fire Protection [Coast, Northern, Southern]

When burning permits are required pursuant to Public Resource Code 4423, timber operators shall:

- (a) Observe the fire prevention and control rules within this article, and
- (b) Submit each year, either before April 1st or before the start of timber operations, a fire suppression resources inventory to the Department as required by the rules.

918.1, 938.1, 958.1 Fire Suppression Resource Inventory [All Districts]

The Fire Suppression Resource Inventory shall include, as a minimum, the following information:

- (a) Name, address and 24-hour telephone number of an individual and an alternate who has authority to respond to Department requests for resources to suppress fires.
- (b) Number of individuals available for fire fighting duty and their skills.
- (c) Equipment available for fire fighting. The Fire Suppression Resource Inventory shall be submitted to the ranger unit headquarters office of the Department having jurisdiction for the timber operation.

918.3, 938.3, 958.3 Roads to be Kept Passable [All Districts]

Timber operators shall keep all logging truck roads in a passable condition during the dry season for fire truck travel until snag and slash disposal has been completed.

918.4, 938.4, 958.4 Smoking and Matches [All Districts]

Subject to any law or ordinance prohibiting or otherwise regulating smoking, smoking by persons engaged in timber operations shall be limited to occasions where they are not moving about and are confined to cleared landings and areas of bare soil at least three feet (.914 m) in diameter. Burning material shall be extinguished in such areas of bare soil before discarding. The timber operator shall specify procedures to guide actions of his employees or other persons in his employment consistent with this subsection.

CALIFORNIA FOREST PRACTICE RULES

918.5, 938.5, 958.5 Lunch and Warming Fires [All Districts]

Subject to any law or ordinance regulating or prohibiting fires, warming fires or other fires used for the comfort or convenience of employees or other persons engaged in timber operations shall be limited to the following condition:

1. There shall be a clearance of 10 feet (3.05 m) or more from the perimeter of such fires and flammable vegetation or other substances conducive to the spread of fire.
2. Warming fire shall be built in a depression in the soil to hold the ash created by such fires.
3. The timber operator shall establish procedures to guide actions of his employees or other persons in their employment regarding the setting, maintenance, or use of such fires that are consistent with (a) and (b) of this subsection.

918.6, 938.6, 958.6 Posting Procedures [All Districts]

Timber operators shall post notices which set forth lists of procedures that they have established consistent with Sections 918.4 [938.4, 958.4] and 918.5 [938.5, 958.5]. Such notices shall be posted in sufficient quantity and location throughout their logging areas so that all employees, or other persons employed by them to work, shall be informed of such procedures. Timber operators shall provide for diligent supervision [*Southern: and enforcement*] of such procedures throughout their operations.

918.7, 938.7, 958.7 Blasting and Welding [All Districts]

Timber operators shall provide for a diligent fire watch service at the scene of any blasting or welding operations conducted on their logging areas to prevent and extinguish fires resulting from such operations.

918.8, 938.8, 958.8 Inspection for Fire [All Districts]

The timber operator or his/her agent shall conduct a diligent aerial or ground inspection within the first two hours after cessation of felling, yarding, or loading operations each day during the dry period when fire is likely to spread. The person conducting the inspection shall have adequate communication available for prompt reporting of any fire that may be detected.

918.10, 938.10, 958.10 Cable Blocks [All Districts]

During the period when burning permits are required, all tail and side blocks on a cable setting shall be located in the center of an area that is either cleared to mineral soil or covered with a fireproof blanket that is at least 15 ft. in diameter. A shovel and an operational full five-gallon back pump or a fire extinguisher bearing a label showing at least a 4A rating must be located within 25 feet of each such block before yarding.

Article 9 Wildlife Protection Practices

919, 939, 959 Wildlife Practice [All Districts]

Timber operations shall be planned and conducted to maintain suitable habitat for wildlife species as specified by the provisions of this Article. These provisions are in addition to those directly or indirectly provided in other rules of the Board.

919.1, 939.1, 959.1 Snag Retention [All Districts]

Within the logging area all snags shall be retained to provide wildlife habitat except as follows:

- (a) If required by the Director during the review of a THP, snags over 20 ft. in height and 16 in. dbh shall be felled in the following locations:
 - (1) Within 100 feet of main ridge tops that are suitable for fire suppression and delineated on a THP map.
 - (2) For hazard reduction within 100 feet of all public roads, permanent roads, seasonal roads, landings, and railroads.
- (b) Where federal and state safety laws and regulations require the felling of snags.
- (c) Within 100 feet of structures maintained for human habitation.
- (d) Merchantable snags in any location as provided for in the plan, or
- (e) Snags whose falling is required for insect or disease control.
- (f) When proposed by the RPF; where it is explained and justified that there will not be a significant

CALIFORNIA FOREST PRACTICE RULES

impact to wildlife habitat needs or there is a threat to human health or safety, including fire where the Director determines a high hazard exists.

919.2, 939.2, 959.2 General Protection of Nest Sites [All Districts]

The following general standards for protection of Sensitive species shall apply:

(a) A pre-harvest inspection will normally be required when it is known or suspected that the minimum buffer zone surrounding an active nest of a Sensitive species is in or extends onto an area proposed for timber operations. When the Department is already familiar with the site, the Director, after consultation with the Department of Fish and Game, may waive this requirement.

(b) During timber operations, nest tree(s), designated perch trees(s), screening tree(s), and replacement trees(s), shall be left standing and unharmed except as otherwise provided in these following rules.

(c) Timber operations shall be planned and operated to commence as far as possible from occupied nest trees unless explained and justified by the RPF in the THP.

(d) When an occupied nest site of a listed bird species is discovered during timber operations, the timber operator shall protect the nest tree, screening trees, perch trees, and replacement trees and shall apply the provisions of subsections (b) and (c) above and shall immediately notify the Department of Fish and Game and the Department of Forestry and Fire Protection. An amendment that shall be considered a minor amendment to the timber harvesting plan shall be filed reflecting such additional protection as is agreed between the operator and the Director after consultation with the Department of Fish and Game.

919.3, 939.3, 959.3 Specific Requirements for Protection of Nest Sites [All Districts]

The following requirements shall apply to nest sites containing active nests and not to nest sites containing only abandoned nests.

(a) Buffer zones shall be established around all nest trees containing active nests. The buffer zones shall be designed to best protect the nest site and nesting birds from the effects of timber operations. In consultation with the Department of Fish and Game, and as approved by the Director, an RPF or supervised designee shall flag the location of the boundaries of the buffer zone, and the configuration of the buffer zone. Consultation with the Department of Fish and Game shall be required pursuant to 14 CCR 898. Consideration shall be given to the specific habitat requirements of the bird species involved when configuration and boundaries of the buffer zone are established.

(b) The size of the buffer zone for each species shall be as follows:

(1) For the Bald Eagle and Peregrine Falcon, the buffer zone shall be a minimum of ten acres in size. The Director may increase the buffer zone beyond 40 acres in size so that timber operations will not result in a "take" of either species. The Director shall develop the buffer zone in consultation with the Department of Fish and Game and the RPF.

(2) For the Golden Eagle, the buffer zone shall be a minimum of eight acres in size.

(3) For the Great Blue Heron and Great Egret, the buffer zone shall consist of the area within a 300-foot radius of a tree or trees containing a group of five or more active nests in close proximity as determined by the Department of Fish and Game.

(4) For the Northern Goshawk, the buffer zone shall be a minimum of five acres in size. When explained and justified in writing, the Director may increase the size of the buffer zone to a maximum of 20 acres when necessary to protect nesting birds.

(5) For the Osprey, the buffer zone shall be up to five acres in size. When explained and justified in writing, the Director may increase the size of the buffer zone to a maximum of 18 acres when necessary to protect nesting birds.

(c) The following year around restrictions shall apply within the buffer zone.

(1) For the Bald Eagle, no clear cutting is allowed within the buffer zone. Selection, commercial thinning, sanitation-salvage, and the shelterwood regeneration method, except for the removal step, are permitted if all trees are marked prior to preharvest inspection. All nest trees containing active nests, and all designated perch trees, screening trees and replacement trees, shall be left standing and unharmed.

(2) For the Golden Eagle, no clear cutting is allowed within the buffer zone. All nest trees containing active nests, and all designated perch trees, screening trees, and replacement tree, shall be left standing and unharmed.

(3) For the Great Blue Heron and Great Egret, all nest trees containing active nests shall be left

CALIFORNIA FOREST PRACTICE RULES

standing and unharmed.

(4) For the Northern goshawk, designated nest trees, screening trees, perch trees, and replacement trees shall be left standing and unharmed. Only the commercial thinning, sanitation-salvage, and selection regeneration methods are permitted in the buffer zone.

(5) For the Osprey, all designated nest trees, perch trees, screening trees, and replacement trees shall be left standing and unharmed. If the RPF believes that retention is not feasible, he/she may propose construction of an artificial nest structure as an alternative.

(6) For the Peregrine Falcon, where timber provides part of the immediate nesting habitat, special cutting prescriptions may be required by the Director on an area up to ten acres in size immediately surrounding the nest. The cutting prescriptions shall protect the nesting habitat.

(d) Critical periods are established for each species and requirements shall apply during these critical periods as follows:

(1) For the Bald Eagle, the critical period is January 15 until either August 15 or four weeks after fledgling, as determined by the Director. During this critical period, no timber operations are permitted within the buffer zone. Exceptions may be approved by the Director, after consultation with the Department of Fish and Game to allow hauling on existing roads that normally receive use within the buffer zone during the critical period.

(2) For the Golden Eagle, the critical period is January 15 until April 15 for active nests, and extended from April 15 until either September 1 or until the birds have fledged for occupied nests. During this critical period, hauling on existing roads that normally receive use during the critical period is permitted. Other operations are not permitted within the buffer zones.

(3) For the Great Blue Heron and Great Egret, the critical period is February 15 until July 1 for coastal counties south of and including Marin County. For all other areas, the period is from March 15 through July 15. During this critical period, timber operations within the buffer zone shall be staged with a gradual approach to the nest.

(4) For the Northern Goshawk, the critical period is from March 15 until August 15. During this critical period, no timber operations are permitted; however, new road construction is permitted if the Director determines that there is no feasible alternative. Exceptions may be approved by the Director after consultation with the Department of Fish and Game to allow hauling on existing roads that normally receive use within the buffer zone during the critical period.

(5) For the Osprey, the critical period is March 1 to April 15 for active nests in coastal counties including Mendocino County and those south of it. This period is extended from April 15 until August 1 for occupied nests. For all other areas, the critical period is March 15 until May 1 for active nests, and is extended from May 1 to August 15 for occupied nests. During the critical period, at nest sites where Osprey have shown historical tolerance to disturbance, timber operations are permitted using a gradual approach to the nest, except that no cutting is permitted. Where Osprey are determined by the Director to be intolerant to timber operations, no timber operations are permitted within the buffer zone unless the Director determines that there are no feasible alternatives.

(6) For the Peregrine Falcon, the critical period is February 1 until April 1 for active nests, and is extended until July 15 for occupied nests. During the critical period, no timber operations are permitted within the buffer zone. However, when the Director, after consultation with the Department of Fish and Game determines that Peregrines have shown a tolerance to hauling activity in the past, hauling on existing roads that normally receive use during the critical period within the buffer zone is permitted.

(e) The following requirements shall apply to helicopter logging during the critical period.

(1) For the Bald Eagle, helicopter yarding within one-quarter mile radius of the nest tree is prohibited. Helicopter yarding between one-quarter and one-half mile of the nest tree is permitted when timber operations are conducted so that helicopter yarding gradually approaches the one-quarter mile radius limit.

(2) For the Golden Eagle and Northern Goshawk, helicopter yarding within one-quarter mile radius of the nest is prohibited.

(3) For the Osprey, helicopter yarding within one-quarter mile radius of the nest is prohibited between April 15 and June 15.

(4) For the Peregrine Falcon, helicopter yarding is prohibited within one-half mile of the nest.

CALIFORNIA FOREST PRACTICE RULES

919.4, 939.4, 959.4 Non-listed Species [All Districts]

Where significant adverse impacts to non-listed species are identified, the RPF and Director shall incorporate feasible practices to reduce impacts as described in 14 CCR 898.

919.5, 939.5, 959.5 Alternatives [All Districts]

The RPF may propose alternatives to the requirements of this chapter, and the Director may approve such alternatives provided all of the following conditions are met:

- (a) The RPF develops the alternative in consultation with the Department of Fish and Game.
- (b) The Director consults with the Department of Fish and Game and makes findings that the alternative conforms to (c), below, prior to approving the alternative.
- (c) The alternative will provide protection for nesting birds and their nesting sites equal to or greater than the protection that would be afforded by the application of the normal rules set forth in this chapter.

919.9, 939.9 Northern Spotted Owl [Coast, Northern]

Every proposed timber harvesting plan, NTMP, conversion permit, Spotted Owl Resource Plan, or major amendment located in the range of the northern spotted owl shall follow one of the procedures required in subsections (a)-(g) below for the area within the boundary as shown on the map and also for adjacent areas as specified within this section. The submitter may choose any alternative (a)-(g) that meets the on-the-ground circumstances. The required information shall be used by the Director to evaluate whether or not the proposed activity would result in the "take" of an individual northern spotted owl.

When subparagraphs (a), (b), or (c) are used, the Director, prior to approval, shall consult with a state employed biologist designated by the Department who is accepted by the Department of Fish and Game or the Fish and Wildlife Service as having sufficient knowledge and education to determine harm or harassment of the Northern Spotted Owl. The biologist shall make written recommendations regarding whether the retained habitat configuration and protection measures proposed in the THP will prevent a take of the owl.

The Department may designate independent biological consultants who can fulfill the requirements within subparagraph (a) of these rules. The plan submitter has the discretion whether to utilize a designated independent consultant under subparagraph (a). All other requirements under the northern spotted owl rules specifying a designated biologist are to be fulfilled by a state-employed biologist. To be designated by the Department, the independent consultant must be accepted by either the Department of Fish and Game or the Fish and Wildlife Service. This acceptance requires the independent consultant to demonstrate, in the field, sufficient knowledge and education to recognize and analyze data from field conditions and present information which helps determine harm or harassment of the northern spotted owl. The same educational and experience criteria utilized to designate state-employed biologists will be applied. When a designated independent consultant is used to fulfill the requirements of subparagraph (a), the independent consultant shall make written observations and recommendations regarding whether the retained habitat configuration and protection measures proposed in the THP will prevent a take of the owl.

In consultation with the state-employed designated biologist, the Director may adjust standards established by this section based on site specific circumstances in a manner which is consistent with information collected on owl behavior in California, and the prohibitions of the Federal Endangered Species Act.

(a) If the project proponent requests preliminary review of the proposed operation or Spotted Owl Resource Plan prior to filing, a designated biologist (either state-employed or an independent consultant) shall be assigned to evaluate whether the proposed operation would result in the taking of an individual northern spotted owl. This evaluation is preliminary to and separate from the final "take" determination to be made under Section 919.10 (939.10). In making that evaluation:

- (1) The designated biologist shall apply the criteria set forth in Section 919.10 [939.10].
- (2) The designated biologist may request that the submitter provide additional information which the designated biologist finds necessary to evaluate if a "take" would occur, provided that the designated biologist states the type of information needed, the purpose of the information, and the level of accuracy necessary to meet the stated purpose.
- (3) If the designated biologist concludes that no prohibited taking would occur, the biologist shall inform the submitter as soon as practicable and shall document the decision and the information which was relied upon by the biologist in the above evaluation. Reference data shall be readily available for the Director's review upon request;

CALIFORNIA FOREST PRACTICE RULES

(4) If the designated biologist concludes that the proposed timber operation or Spotted Owl Resource Plan would result in a taking, he or she shall inform the submitter as soon as practicable and shall comply with Section 919.10(c) [939.10(c)] within 10 working days of making this determination.

(5) Requests for pre-filing consultation shall be handled in the order in which received.

(b) The RPF shall include the following information:

(1) On a planimetric or topographic map of a minimum scale of 1:24,000, provide the following:

(A) The location and acreage of owl habitat. This information shall be shown for the area within the boundary both as it exists before and after timber operations. The Director shall determine if timber typing maps may qualify as showing owl habitat.

(B) Identify any adjoining owl habitat by type within .7 miles of the boundary.

(C) When mapping functional owl nesting, roosting, and foraging habitat, include additional information which helps define those areas such as: location of topography features, riparian vegetation, hardwood component, water, potential nest and roost sites, and potential suitable forage areas.

(D) All known owl observations, identified by location and visual or nonvisual confirmation within 1.3 miles of the boundary. This information shall be derived from the landowners and RPF's personal knowledge, and from existing spotted owl data bases available from the Department.

(2) Discussion on how functional characteristics of owl habitat will be protected in terms of the criteria stated within Section 919.10(a) and (b) [939.10(a) and (b)].

(3) As adjacent landowners permit and from other available information, a discussion of adjacent owl habitat up to .7 mile from the proposed boundary and its importance relative to the owl habitat within the boundary.

(4) Describe any proposals for monitoring owls or owl habitat which are necessary to insure their protection. Monitoring is not required for approval.

(5) Discussion of any known owl surveys that have been conducted within 1.3 miles of the boundary. Include the dates, results and methodologies used if known.

(6) A proposed route that will acquaint the designated biologist and other reviewers with the important owl habitat.

(7) Attach aerial photos of the area, if available. (Aerial photos are not required.)

(c) Where certification is made by the RPF and adequate records are kept showing that owl surveys were conducted sufficient to demonstrate the absence of owls from an area, there will be a high priority review. There shall be verification that:

(1) The surveys have been conducted throughout the area within .7 miles of the boundary in accordance with the USFWS approved protocol ("Guidelines for Surveying Proposed Management Activities Which May Impact Northern Spotted Owls"; USFWS; March 7, 1991).

(2) The surveys were conducted during the current or immediately preceding survey period as prescribed by the protocol cited in (c) (1) above.

(3) The surveys reveal no nest sites, activity centers or owl observations in the area surveyed; and

(4) The surveys reveal no activity centers, active nest sites or repeated observations indicating the presence of mates and/or young are within 1.3 miles of the boundary based on a review of the landowner and RPF's personal knowledge and the Department's spotted owl data base.

(d) If the plan submitter proposes to proceed under an "incidental taking" permit or any other permit covering the Northern spotted owl issued by the U.S. Fish and Wildlife Service, the submitter shall supply a copy of the permit upon the Department's request.

(e) If the submitter proposes to proceed pursuant to the outcome of a discussion with the U.S. Fish and Wildlife Service, the submitter shall submit a letter prepared by the RPF that the described or proposed management prescription is acceptable to the USFWS.

(f) If:

(1) The submitter's proposed operations were reviewed by a designated biologist under Section 919.9(a) [939.9(a)]; and

(2) The designated biologist recommended minimum modifications to the proposed operations which would be necessary to bring the impacts to a level at which no "take" would occur and the submitter has adopted those recommendations; and

CALIFORNIA FOREST PRACTICE RULES

(3) The proposed operations remain substantially the same as the operations which the designated biologist reviewed, the submitter shall provide a copy of the recommendations made by the designated biologist and the submitter shall explain how the proposed operations comply with those recommendations.

(g) Where a nest site or activity center has been located within the THP boundary or within 1.3 miles of that boundary, the RPF shall determine and document that the habitat described in (1)-(5) below will be retained after the proposed operations are completed:

(1) Within 500 ft. of the active nest site or pair activity center the characteristics of functional nesting habitat must be maintained. No timber operations shall be conducted in this area during the breeding season unless reviewed by the Department of Fish and Game and approved by the Director as not constituting a take. Timber operations may be conducted in this area outside the breeding season if appropriate measures are adopted to protect nesting habitat.

(2) Within 500-1000 ft. of the active nest site or pair activity center, retain sufficient functional characteristics to support roosting and provide protection from predation and storms.

(3) 500 acres of owl habitat must be provided within a .7 mile radius of the active nest site or pair activity center, unless an alternative is reviewed by the Department of Fish and Game and approved by the Director as not constituting a take. The 500 acres includes the habitat retained in subsections (1) and (2) above and should be as contiguous as possible. Less than 50% of the retained habitat should be under operation in any one year, unless reviewed by the Department of Fish and Game and approved by the Director.

(4) 1336 total acres of owl habitat must be provided 1.3 miles of each nest site or pair activity center, unless an alternative is reviewed by the Department of Fish and Game and approved by the Director as not constituting a take. The 1336 acres includes the habitat retained within subsections (1) - (3) above.

(5) The shape of the areas established pursuant to subsections (1) and (2) shall be adjusted to conform to natural landscape attributes such as draws and streamcourses while retaining the total area required within subsections (1) and (2) above.

919.10, 939.10 Take of Northern Spotted Owl [Coast, Northern]

The designated biologist and the Director shall apply the following criteria to the information provided by the plan submitter and obtained during the review period to make a finding as to whether the timber operations, as proposed, will "take" an individual northern spotted owl. The designated biologist shall use the best professional judgment in making that finding.

(a) The designated biologist and the Director shall determine that the proposed habitat modification would result in "harm" to an individual spotted owl if any of the following conditions exist.

(1) Feeding habits would be significantly impaired because prey base or ability to catch prey would be adversely altered;

(2) Breeding success would be significantly impaired because of a reduction in surrounding owl habitat before the young have had an opportunity to successfully disperse from their nesting site;

(3) Nesting behavior would be significantly impaired because the nest site or adjoining area up to 500 ft. from the nest site would be adversely altered; or

(4) Sheltering (which includes roosting, feeding, and nesting) would be significantly impaired because the ability to escape predators, survive severe weather, or find appropriate microclimates would be adversely altered.

(b) The designated biologist and the Director shall determine that an individual northern spotted owl would be "harassed" by the proposed timber operations if there is a likelihood that any of the following conditions exist:

(1) Feeding habits would be significantly disrupted because the prey base or the ability to catch prey would be impaired;

(2) Breeding success would be significantly disrupted;

(3) Nesting behavior would be significantly disrupted because activities would be conducted within 500 feet of a nest site; or

(4) Sheltering (which includes roosting, nesting, or feeding) would be significantly disrupted because the ability to escape predators, survive severe weather, find appropriate microclimates would be adversely altered.

CALIFORNIA FOREST PRACTICE RULES

(c) If the designated biologist concludes that the proposed operations will result in a taking of the owl, he/she shall provide the plan submitter with the following information:

- (1) The reasons for the determination, including an analysis of the factors set forth in this section;
- (2) The information which was relied upon and which was instrumental in making the determination; and
- (3) Recommendations for minimum modifications to the proposed operations which would be necessary to bring the impacts to a level at which "take" would not occur.

919.11 Marbled Murrelet Protective Measures [Coast]

Where there is evidence of an active murrelet site in or adjacent to the THP area, as defined in "*Addendum to Surveying Marbled Murrelets at Inland Forested Sites: A Guide for California Coastal Forests*" C.J. Ralph, April 1991 or where there is evidence of a potential impact to a murrelet, the Director shall consult with DFG as to whether the proposed THP will result in a "take" or "jeopardy" (pursuant to the California Endangered Species Act) of the murrelet before the Director may approve or disapprove a THP. Biological Assessments submitted with the THP that are prepared according to the Department of Fish and Game Guidelines for Consultation (F&GC Sec. 2090) shall be provided to the DFG during consultation. If DFG determines jeopardy or a take will occur as a result of operations proposed in the THP, the Director shall disapprove the THP unless the THP is accompanied by authorization by a wildlife agency acting within its authority under state or federal endangered species acts.

919.12, 939.12, 959.12 Sensitive Species Classification [All Districts]

The Board has the responsibility under the FPA to provide protection to all species occurring in the state's forestlands. The procedure to identify those species that warrant special protection during timber operations is described as follows:

(a) The public or public agencies may petition the Board to classify a species as a "sensitive species." For the Board to consider such a petition, it must contain a discussion of the following topics:

- (1) Range and distributional status of the species which includes an assessment of occurrence in timberland as defined by the FPA and the rules.
- (2) Indices of population trends describing the abundance of the species.
- (3) Biotic and abiotic factors affecting the population viability or status of the species. Specific attention should be given to factors related to forest management and harvesting. This should include threats to population and habitat viability, including direct, indirect, and cumulative effects from these and other threats.
- (4) Habitat availability and trends that include, but are not limited to, an assessment of the following as appropriate:
 - (A) Dependence on general habitat conditions altered by typical forest management activities and projected time for habitat recovery.
 - (B) Dependence on special habitat elements adversely impacted by timber operations,
 - (C) Habitat continuity and juxtaposition requirements as an evaluation of sensitivity to habitat fragmentation.
- (5) Suggested feasible protective measures required to provide for species protection.
- (6) Other information specific to the species proposed that the petitioner believes to be relevant in assisting the Board to evaluate the petition.
- (7) Sources of information relied upon to complete the petition.
- (8) Recommended forest practice rules to provide guidance to RPFs, LTOs, landowners and the Director on species protection.
- (9) The potential economic impacts of classifying a species sensitive.

(b) The Board will consult with the U.S. Fish and Wildlife Service, the California Fish and Game Commission, the California Department of Fish and Game, and others as appropriate. After consultation the Board shall classify a species as sensitive after a public hearing if it finds:

- (1) The California population requires timberland as habitat for foraging, breeding, or shelter, and
- (2) The California population is in decline or there is a threat from timber operations, and
- (3) Continued timber operations under the current rules of the Board will result in a loss of the California population viability.

CALIFORNIA FOREST PRACTICE RULES

(c) The Board shall consult with the U.S. Fish and Wildlife Service, the California Department of Fish and Game, and others as appropriate. After consultation and a public hearing, the Board will declassify a species as sensitive if it no longer meets the criteria for classification.

(d) The Board shall consider, and when possible adopt, regulations using the best available scientific information to establish the feasible mitigations for protection of the species at the same time such species is classified sensitive.

(e) Where rules are not adopted for the protection of the species at the time of classification, the Board shall begin development of proposed regulations for protection of the species.

Within one year of the classification of a species as sensitive, the Board shall hold a hearing on proposed regulations to establish the protection standards for that species according to the best available scientific information.

939.15 Protection of Wildlife Habitat [Northern]

All trees within meadows and wet areas may be clearcut and these are exempted from stocking provisions in order to attain or retain these areas for wildlife and livestock. These areas shall be shown on the plan map.

959.15 Protection of Wildlife Habitat [Southern]

(a) Where present at time of timber harvest, 400 sq. ft. basal area of oak per 40 acres should be retained and protected, giving preference to deciduous oaks. Oaks should be retained on areas designated by DFG as deer migration corridors, holding areas, or key ranges when consistent with good forestry practices.

(b) Trees within meadows and wet areas may be clearcut and these areas exempted from the stocking provisions of the rules in order to retain these areas for wildlife. These areas shall be shown on the plan.

919.16, 939.16, 959.16 Late Succession Forest Stands [All Districts]

(a) When late succession forest stands are proposed for harvesting and such harvest will significantly reduce the amount and distribution of late succession forest stands or their functional wildlife habitat value so that it constitutes a significant adverse impact on the environment as defined in Section 895.1, the RPF shall provide habitat structure information for such stands. A statement of objectives over time shall be included for late succession forest stands on the ownership. The THP, SYP, or NTMP shall include a discussion of how the proposed harvesting will affect the existing functional wildlife habitat for species primarily associated with late succession forest stands in the plan or the planning watershed, as appropriate, including impacts on vegetation structure, connectivity, and fragmentation. The information needed to address this subsection shall include, but is not limited to:

(1) - A map(s) showing: A) late succession forest stands within the planning watershed and any other stands that provide functional wildlife habitat for species primarily associated with late succession forest stands that are on the ownership, B) those stands which are currently proposed to be harvested, and C) known stands on other ownerships.

(2) - A list of fish, wildlife and listed species known to be primarily associated with the late succession forest stands in the planning watershed(s) compiled by the RPF or supervised designee using the "California Wildlife Habitat Relationships System" (WHR), the California Natural Diversity Database, and local knowledge of the planning watershed.

(3) - Description of functional wildlife habitat elements that are important for fish, wildlife and listed species primarily associated with late succession forest stands within the planning watershed(s).

(4) - A description of the structural characteristics for each late succession forest stand and any other stands that provide functional wildlife habitat for species primarily associated with late succession forest stands within the planning watershed including a discussion of important functional wildlife habitat elements identified in (3). Methods used to develop the description, which may be an ocular estimate, shall also be described.

(5) - A description of the functional wildlife habitat objectives, such as anticipated long-term landscape patterns, stand structure for late succession forest stands and any other stands that provide functional wildlife habitat for species primarily associated with late succession forest stands, and a discussion of anticipated recruitment procedures for important functional wildlife habitat elements. Coordination of functional wildlife habitat objectives on landscape features among ownerships within mixed-ownership planning watersheds is encouraged.

CALIFORNIA FOREST PRACTICE RULES

(6) - An analysis of the long-term significant adverse effects on fish, wildlife, and listed species known to be primarily associated with late succession forests.

(b) Where timber operations will result in long-term significant adverse effects on fish, wildlife, and listed species known to be primarily associated with late succession forests in a THP, SYP, NTMP or planning watershed, feasible mitigation measures to mitigate or avoid such long-term significant adverse effects shall be described and incorporated in the THP, SYP or NTMP. Where long-term significant adverse effects cannot be avoided or mitigated, the THP, SYP, or NTMP shall identify the measures that will be taken to reduce those remaining effects and provide reasons for overriding concerns pursuant to 14 CCR Section 898.1 (g), including a discussion of the alternatives and mitigation considered.

(c) A THP, SYP, or NTMP submitter may request that the Director waive subsection (a) above. The Director, after conferring with review team agencies with jurisdiction, may waive subsection (a) above when substantial evidence is presented that would support a determination that post-harvest late succession forest stands or functional wildlife habitat will continually provide adequate structure and connectivity to avoid or mitigate long-term significant adverse effects on fish, wildlife, and listed plant species known to be primarily associated with late succession forest stands within the planning watersheds.

Article 10 Violations of Rules Prior to Changes

920, 940, 960 Violations of Rules Prior to Changes [All Districts]

Amendment, modification, or repeal of rules shall not, unless otherwise provided, bar action on prior violations of rules as they stood at the time of violation.

Article 11 Coastal Commission Special Treatment Areas

921, 961 Coastal Commission Special Treatment Areas [Coast, Southern, Special Treatment Area]

The purpose of this article is to protect the natural and scenic qualities as reflected in the criteria and objectives for each of the Coastal Commission Special Treatment Areas designated and adopted by the California Coastal Commission on July 5, 1977, while at the same time allowing management and orderly harvesting of timber resources within these areas. In addition to the statutes and other regulations governing timber harvesting, the following practices are required when conducting timber operations in such Special Treatment Areas.

921.1 Preliminary Field Work and Timber Harvesting Plans [Coast, Special Treatment Area]

(a) The following preliminary field work shall be required in the Coastal Commission Special Treatment Areas and shall be completed prior to submission of the plan to the Director:

(1) When a boundary of a Coastal Commission Special Treatment Area is within or contiguous to a plan area, the boundary shall be clearly identified on the ground by the RPF preparing the plan or supervised designee, with paint, flagging, or other suitable means.

(2) All tractor roads and skid trails that require substantial soil displacement shall be clearly marked on the ground with flagging or other appropriate marking.

(3) The boundary of all slides and areas with visible evidence of slope instability which extend to the watercourse and lake protection zone shall be flagged or otherwise adequately marked on the ground.

(4) The following wildlife consideration shall be followed:

(A) Live trees, as designated on the ground by the Departments of Fish and Game or Forestry or the RPF or supervised designee with visible evidence of current use as nesting sites by hawks, owls, or waterfowl shall not be marked for cutting.

(5) In applying the rules, the RPF shall, when selecting feasible alternatives required by 14 CCR 898, follow the criteria and management objectives used by the Coastal Commission in selecting that area for special treatment (see Title 14, California Administrative Code, Sec. 912).

(b) The following shall be adhered to in submitting plans for Coastal Commission Special Treatment Areas:

(1) Plan maps shall be at a scale of at least 4 inches to the mile (6.3 cm per km)

(2) Plan maps must show the location of and identify the following: All log landings proposed to be used, and all main skid trails, all logging roads, all watercourses, lakes, marshes and boundaries of Coastal

CALIFORNIA FOREST PRACTICE RULES

Commission Special Treatment Areas within or contiguous to the plan area.

(3) An initial inspection of the area in which timber operations are to be conducted shall be made within 10 days from the date of filing of the plan, or such longer period as may be mutually agreed upon by the Director and the person submitting the plan. The RPF who prepared the plan shall attend the initial inspection. The timber owner and timber operator or their agents should attend the initial inspections.

961.1 Preliminary Field Work and Timber Harvesting Plans [Southern, Special Treatment Area]

(a) The following preliminary field work shall be required in the Coastal Commission Special Treatment Areas and shall be completed prior to submission of the plan to the Director.

(1) When a boundary of a Coastal Commission Special Treatment Area is within or contiguous to a plan area, the boundary shall be clearly identified on the ground by the RPF preparing the plan or supervised designee, with paint, flagging, or other suitable means.

(2) All timber proposed for harvest shall be clearly marked with paint at points approximately 4 1/2 feet (1.37 m) above the ground and at ground level.

(3) The following wildlife considerations shall be followed:

(A) Live trees, as designated on the ground by the Departments of Fish and Game or Forestry and Fire Protection or the RPF or supervised designee, with visible evidence of current use as nesting sites by hawks, owls, or waterfowl shall not be marked for cutting.

(B) Live trees as designated on the ground by the Departments of Fish and Game or Forestry and Fire Protection or the RPF or supervised designee, with visible evidence of nesting by eagles, osprey, or any endangered species, as identified by the Department of Fish and Game, shall not be marked for cutting.

(C) Live trees constituting a rookery for herons and/or egrets shall not be marked for cutting unless authorization in writing from the Department of Fish and Game is granted to the timber owner.

(4) All logging roads proposed to be constructed or reconstructed, main skid trails and those minor skid trails that would require or result in substantial soil displacement, and landing locations shall be clearly marked on the ground with flagging or other appropriate marking, keyed to the various projects.

(5) The boundary of the watercourse and lake protection zones shall be flagged or otherwise marked on the ground and shall include all slides and areas with visible evidence of slope instability which extend to the watercourse and lake protection zone.

(b) The following requirements shall be adhered to in submitting plans in Coastal Commission Special Treatment Areas:

(1) Plan maps shall be at a scale of at least 4 inches to the mile (6.3 cm per km).

(2) The plan map must show the location and identify the following: All log landings proposed to be used, and all main skid trails, all logging roads, all watercourses, lakes, marshes and boundaries of Coastal Commission Special Treatment Areas within or contiguous to the plan area.

(3) An initial inspection of the area in which timber operations are to be conducted shall be made within 10 days from the date of filing of the plan, or such longer period as may be mutually agreed upon by the Director and the person submitting the plan. The RPF who prepared the plan shall attend the initial inspection. The timber owner and timber operator or their agents should attend the initial inspections.

921.2 Exemptions from Timber Harvesting Plan Requirements [Coast, Special Treatment Area]

To ensure that the protection necessary to maintain the integrity of Coastal Commission Special Treatment Areas is achieved, the following requirements shall apply to the timber operations exempt from filing of THPs under 14 CCR 1038.

(a) The requirements of 14 CCR 921.1(a) and (b) shall apply with the exception that, at the discretion of the Director, an initial inspection may not be required. Harvesting of Christmas trees are exempt from timber marking requirements.

(b) The Director shall acknowledge in writing, and within 10 days, acceptance or rejection of the notice of timber operations. Timber operations shall not commence until the Director's acceptance has been received by the person who filed the notice.

(c) The requirements of PRC 4585, Completion Report, and PRC 4587, Stocking Reports, shall apply to exempt operations within the Coastal Commission Special Treatment Areas.

CALIFORNIA FOREST PRACTICE RULES

961.2 Exemptions from Timber Harvesting Plan Requirements [Southern, Special Treatment Area]

Notwithstanding 14 CCR 1038, exemptions from plan filing requirements in the Coastal Commission Special Treatment Areas shall only be allowed for minor operations where no live trees are cut.

921.3 Silvicultural Methods [Coast, Special Treatment Area]

The objective of this Section is to prescribe silvicultural methods that will protect the long-term productivity of soils and timberlands in Coastal Commission Special Treatment Areas and protect the natural and scenic qualities of these areas. The following silvicultural methods as prescribed below will be applied in Coastal Commission Special Treatment Areas. 14 CCR 913 through 913.6 defines these methods.

(a) Commercial Thinning or Selection Methods: When the commercial thinning or the selection silvicultural method is used the following standards are required:

(1) For an initial entry into an even-aged stand, leave a well distributed timber stand after cutting and logging operations have been completed on the cut area at least 40% by number of those trees 18 inches (45.7 cm) and more d.b.h. present prior to commencement of current timber operations and at least 50% by number of those over 12 inches (30.5 cm) d.b.h. but less than 18 in. (45.7 cm) or more d.b.h. All leave trees shall be thrifty coniferous trees which are free from substantial damage caused by timber operations, and leave trees shall have the characteristics of a "countable tree" as described in Section 4528(b). No conifer tree shall be cut which is more than 75 feet (22.86 m) from a leave tree 12 inches (30.5 cm) d.b.h. or larger located within the logging area. Average top stump diameter, outside bark, shall be considered 1 in. (2.5 cm) greater than d.b.h.

(2) For timber stands where more than one age class is present, leave at least 50% by number of those trees over 12 in. d.b.h. leave trees and established conifer regeneration shall amount to 50% of the pre-existing tree crown canopy cover. All leave trees shall be thrifty coniferous trees which are free from substantial damage caused by timber operations, and leave trees shall have the characteristics of a "countable tree" described in Sec. 4528(b) PRC. No conifer tree shall be cut which is more than 75 ft. from a 3 point countable tree within the logging area.

(3) A report of stocking as described in PRC 4587 shall be filed within six months following completion of work as described in the plan.

(b) Sanitation-Salvage Method: When the sanitation-salvage silvicultural method is used the following practices be required:

(1) Restrictions on time periods for subsequent timber operations shall not apply to the sanitation-salvage silvicultural method.

(2) A determined effort shall be made to regenerate any cut area during the first planting season following log removal. Necessary site preparation, planting or seeding shall be complete within the first planting season following logging, except where unusual and adverse weather conditions require extending site preparation and planting into the following planting season. Deficiencies in stocking shall be corrected by planting annually at least three times if necessary to meet the stocking standards in 14 CCR 921.4.

(3) Where the result of the cutting would have the effect of a clearcut all of the restrictions in this section pertaining to the use of clearcut shall apply, except for: 1) areas which are currently suffering severe damage due to insects or disease and the removal of the entire affected area is deemed necessary by a forest pathologist or forest entomologist and agreed to by the Director to prevent the spread of the disease or insects, or 2) except for areas which have recently been burned over and the RPF determined recovery of the affected area is unlikely.

(c) Clearcutting Method: The clearcutting method provides for harvesting of the entire existing timber stand in one harvest in an area. Every reasonable effort shall be made by the RPF to use silvicultural methods other than clearcutting to protect the natural and scenic values in the Coastal Commission Special Treatment Areas. The clearcutting method is not authorized for Special Treatment Areas in the Southern Subdistrict of the Coast Forest District.

(1) The clearcutting method may be used when justified and explained in the plan and found in conformance by the Director for one or more of the following reasons:

(A) Leave trees would be subject to severe damage from sunburn, saltburn, and/or windthrow.

(B) Conifer stand improvement necessitates the clearing of a stand of hardwoods.

(C) Leave trees would prevent regeneration of the principal conifer species.

CALIFORNIA FOREST PRACTICE RULES

(D) Old growth stands where 70% or more of the countable trees over 36 inches (91.4 cm) d.b.h. are more than 200 years old.

(E) Timber stands where trees are infected with insects or diseases, and there is significant risk for substantial loss of standing timber or timber growth.

(2) Clearcut areas shall not exceed 10 acres (4.047 ha) in size, but may be enlarged to not more than 15 acres (6.070 ha) when explained and justified in the plan, and when found in conformance with the rules of the Board. Exceptions to the 10 acre (4.047 ha) size limit may be proposed by the RPF preparing the plan when in his or her judgment the result will be overall reduction of soil erosion due to logging and road construction, or when it is necessary to include "long corners" to take advantage of topography for a more natural logging unit.

(3) Clearcut areas of 10 acres or larger regardless of ownership shall be separated by a logical logging unit not less than 300 ft. (91.44 m) in width between the clearcut areas. Except for the sanitation-salvage, commercial thinning, and selection silvicultural method, no other harvesting shall take place in the unit adjacent to the clearcut areas until a 50% crown cover of conifer tree species has been attained in the clearcut areas. Contiguous clearcuts may occur without regard to ownership only when the total combined acreage in the area clearcut is no more than ten acres.

(4) Straight boundaries and a quadrilateral appearance should be avoided in defining and logging the area to be clearcut. The outline of the clearcut area should, where possible, be in accordance aesthetically with natural pattern and features of the topography.

(5) The area to be clearcut must be clearly defined on the ground prior to initial inspection so the Department can readily determine if the full intent of the regulations will be complied with.

(6) No area previously cut under any other silvicultural method, except the sanitation-salvage method, shall be clearcut until 10 years have elapsed.

(7) Regeneration after clearcutting shall be obtained by using conifer trees or seed appropriate to the site. Site preparation and the planting of seedlings and/or seeding shall be completed within the first planting season following logging except where unusual and adverse weather conditions require extending site preparation and planting into the following planting season. Deficiencies in stocking shall be corrected by planting annually, if necessary. Stocking requirements shall be met within 5 years after completion of timber operations.

(d) Rehabilitation Cutting: Rehabilitation cutting may be applied to stands where the primary forest management objective is to reestablish full conifer stocking on lands where brush and hardwoods are the predominate species. Areas harvested for rehabilitation purposes must be significantly understocked with conifers prior to the proposed harvest. The Director may request that a report of stocking be submitted by the RPF prior to approval of the plan. This report will be requested when it cannot be mutually resolved on the ground that the area is significantly understocked. Restrictions applicable to clearcutting in 14 CCR 921.3(c) shall apply to rehabilitation cutting. Leave trees shall be marked in areas harvested for rehabilitation purposes.

(e) Recutting of Logging Areas: Timber operations for removal of trees may only be repeated on a logging area within less than 10 years after completion of a previous timber operation if minimum stocking standards have been met, the reasons for the operation are justified and explained in the plan, and the scenic and/or natural qualities of a stand would be enhanced by lighter or more frequent tree removal. In no instance shall stocking be reduced below the standards provided in 14 CCR 921.4 nor shall more than 60% by numbers of those trees 18 in. (45.7 cm) and more d.b.h. and no more than 50% by numbers of those trees over 12 in. (30.5 cm) d.b.h. but less than 18 in. (45.7 cm) d.b.h. be removed within any one 10 year period. On timber operations in which cutting has occurred within 10 years preceding the current operations, stumps which are the result of cutting trees within the preceding 10 years shall be counted as trees cut during the current operation in determining percent of trees cut. Timber operations conducted under the Sanitation-Salvage Silvicultural Method, and the harvesting of minor forest products and incidental vegetation are exempt from the above provisions of this Section.

961.3 Silvicultural Methods [Southern, Special Treatment Area]

The objective of this Section is to prescribe silvicultural methods that will protect the long-term productivity of soils and timberlands in Coastal Commission Special Treatment Areas and protect the natural and scenic qualities of these areas. The following silvicultural methods as prescribed below will be applied

CALIFORNIA FOREST PRACTICE RULES

in Coastal Commission Special Treatment Areas. 14 CCR 953 through 953.13, defines these methods.

(a) Commercial Thinning or Selection Methods: When the commercial thinning or the selection silvicultural method is used the following standards are required:

(1) In the pine type, after timber operations have been completed, at least 50% by number of those trees 18 in. (45.7 cm) or larger d.b.h. and at least 50% by number of those trees 12 in. (30.5 cm) d.b.h., but less than 18 in. (45.7 cm) d.b.h. must be left.

(2) In the redwood type, after timber operations have been completed, at least 50% by number of those trees 12 to 18 in. (30.5 cm to 45.7 cm), 18 to 32 in. (45.7 cm to 81.3 cm) and 32 in. (81.3 cm) or larger d.b.h. must be left.

(3) These leave tree requirements shall be calculated from the timber stand existing prior to the commencement of timber operations. Leave trees shall be thrifty, coniferous trees which are dominant or co-dominant in crown class prior to timber harvesting or which have crowns typical of such dominant and co-dominant trees. They shall be free from substantial damage caused by timber operations. No cut conifer tree shall be more than 75 ft. (22.86 m) from a leave tree over 18 in. (45.7 cm) d.b.h. located within the logging area.

(4) Immediately following completion of timber operations, stocking must meet or exceed stocking standards of 14 CCR 961.4.

(5) A report of stocking as described in PRC 4587 shall be filed within six months following completion of work as described in the plan.

(b) When the Sanitation Salvage Silvicultural Method is used, the following practices are required:

(1) A determined effort shall be made to regenerate any cut area during the first planting season following log removal. Necessary site preparation, planting or seeding shall be completed within the first planting season following logging except where unusual and adverse weather conditions require extending site preparation and planting into the following planting season. Deficiencies in stocking shall be corrected by planting annually until final stocking requirements are met.

(2) Operations utilizing the sanitation salvage silvicultural method shall meet the basal area or point count stocking standards of 14 CCR 961.4 within 5 years after the completion of timber operations.

(c) The standards for silvicultural methods under this section may be modified when explained and justified in the plan. Proposed modifications shall protect the natural and scenic qualities of the Coastal Commission Special Treatment Areas to at least the same extent as otherwise provided in these rules.

921.4, 961.4 Stocking Requirements [Coast, Southern, STA]

The stocking standards for understocked timberlands and substantially damaged timberlands as provided for by 14 CCR 1080 through 1081.1 and 1085 through 1085.6 are not applicable in Coastal Commission Special Treatment Areas in the Coast [*Southern*] Forest District. After completion of timber operations one of the following stocking standards must be met:

(a) Basal Area. The average residual basal area, (measured in stems 1 in. (2.5 cm) or larger in diameter Coast) shall be at least 125 sq. ft. per acre (28.69 sq. m per ha) on Site I lands, at least 100 sq. ft. per acre (22.96 sq. m per ha) on Site II and Site III lands and at least 75 sq. ft. per acre (17.22 sq. m per ha) on Site IV and V lands, or

(b) Point Count. The area contains an average point count as specified below:

(1) On Site I and II lands, the area contains an average point count of 450 per acre (1111.9 per ha) to be computed as follows:

(A) 450 countable trees per acre (1111.9 per ha) not more than 4 in. (10.2 cm) d.b.h.; each tree to count as 1 towards meeting stocking requirements.

(B) 150 countable trees per acre (370.6 per ha) over 4 in. (10.2 cm) d.b.h. and not more than 12 in. (30.5 cm) d.b.h.; each tree to count as 3 toward meeting stocking requirements.

(C) 75 countable trees per acre (185.3 per ha) over 12 in. (30.5 cm) d.b.h.; each tree to count as 6 toward meeting stocking requirements.

(2) On Site III, IV, and V lands the area contains an average point count of 300 per acre (741.3 per ha) to be computed as follows:

(A) 300 countable trees per acre (741.3 per ha) not more than 4 in. (10.2 cm) d.b.h.; each tree to count as one toward meeting stocking requirements.

(B) 100 countable trees per acre (247.1 per ha) over 4 in. (10.2 cm) d.b.h. and not more than

CALIFORNIA FOREST PRACTICE RULES

12 inches (30.5 cm) d.b.h.; each tree to count as three toward meeting stocking requirements.

(C) 50 countable trees per acre (123.5 per ha) over 12 in. (30.5 cm) d.b.h.; each tree to count as six toward meeting stocking requirements.

Redwood root crown sprouts will be counted using the average stump diameter 1 ft. (.305 m) above average ground level of the original stump from which the redwood root crown sprouts originate, counting one sprout for each 1 ft. (.305 m) of stump diameter to a maximum of six per stump.

Site classification shall be determined by the RPF who prepared the plan. Rock outcroppings, meadows, wet areas, or other areas not normally bearing timber shall not be considered as requiring stocking and are exempt from such provisions.

921.5 Logging Practices [Coast, Special Treatment Area]

The following logging practices shall be adhered to:

(a) Tractor Logging: Tractor logging and tractor preparation of tree layouts shall not be permitted on slopes averaging over 50% where the Erosion Hazard Rating is high or extreme and 60% where the Erosion Hazard Rating is low or moderate, unless it can be shown from past experience on the ground that tractor logging or other types of skidding equipment will cause less disturbance than would result from a feasible alternative method.

(b) Roads: Rules contained in 14 CCR 923.2 through subsection (f) shall be adhered to with the following special requirements.

(1) Roads shall be single lane, not to exceed 16 ft. in width and generally the traveled surface shall be no more than 12 ft. (3.67 m) in width, except where alignment, safety, and equipment necessary to conduct the operation requires additional width. Deviations shall be explained and justified in the plan.

(2) Waste organic material such as uprooted stumps, cull logs, accumulations of limbs and branches, or nonmerchantable trees shall not be buried in the main body of road fills. Such solid waste material may be used to secure the toe of a fill. Except for prepared crossings, including necessary approaches, sidecast or fill material shall not be placed in the watercourse protection zone unless explained in the plan.

(3) Roads shall not be constructed through slide areas or areas with visible evidence of slope instability unless the alignment is the best available alternative and special design features are incorporated in the plan. There shall be provisions in the plan to maintain the design features or provisions to maintain or improve the stability of the area after completion of road use.

(4) Roads, landings, cuts and fills shall be screened from direct view to the extent feasible by leaving screen trees and other vegetation between the disturbed areas and public areas utilized by substantial numbers of viewers.

(c) Soil disturbance, other than that incident to necessary road maintenance, whether with tractor or by cable means, shall not occur under excessively wet ground conditions that could result in substantial soil compaction and erosion.

(d) Notwithstanding the requirements of 14 CCR 1040, if in construction, rock outcroppings, springs and other physical factors require a change in roads, landings and skid trail location, the location can be changed with the concurrence of an RPF, the operator and the Director's representative provided that such changes in location constitute minor deviations: that RPF shall provide written confirmation of such minor deviations which shall become a part of the plan. All changes in location constituting substantial deviations shall be submitted to the Director as amendments to the plan.

(e) Felling Practices: Up to 10% of the trees that are proposed for cutting may be substituted one for one with those proposed to be left uncut provided that the leave tree proportion, size class, distribution and general forest appearance of the residual stand as approved in the preliminary field work is preserved. Justification for the substitution standard shall be based on unavoidable tree damage, safety factors, lean of trees, location of obstructions or roads or openings insufficient to accommodate felled trees.

961.5 Logging Practices [Southern, Special Treatment Area]

The following logging practices shall be adhered to:

(a) Tractor logging and tractor preparation of tree layouts shall not be permitted on slopes averaging over 50% unless it can be shown that tractor logging will result in less soil disturbance than would result from an alternative method.

(b) Roads shall be single lane, and generally the travel surface shall be no more than 12 ft. (3.67 m) in

CALIFORNIA FOREST PRACTICE RULES

width, except where alignment, safety, and equipment necessary to conduct the operation requires additional width. Deviations shall be explained and justified in the plan.

(c) An RPF may obtain a relocation of the main skid trails from that shown on the approved plan if the Director concurs after an inspection on the ground. Such relocation may be treated as a minor deviation with the plan so amended.

(d) Roads shall not be constructed through slide areas or areas with visible evidence of slope instability unless the alignment is the best available alternative and special design features are incorporated in the plan. There shall be provisions in the plan to maintain the design features or provisions to maintain or improve the stability of the area after completion of the use.

(e) Roads, landings, cuts and fills shall be screened from direct view to the extent feasible by leaving screen trees and other vegetation between the disturbed areas and public areas utilized by substantial numbers of viewers.

(f) Soil disturbance, other than that incident to necessary road maintenance, whether with tractor or by cable means, shall not occur under excessively wet ground conditions that could result in substantial soil compaction and erosion.

921.6 Hazard Reduction [Coast, Special Treatment Area]

(a) Lopping: Except in the southern subdistrict, to reduce fire hazards, maintain soil fertility, reduce erosion, and improve visual appearance, all slash and debris created by the current operations and within 300 ft. of public roads and watercourses open to the public shall be lopped and scattered, chipped, or crushed, prior to April 1st of the year following its creation, so that no material generally remains more than 30 in. (762 cm) above the ground.

As an exception to the above requirements after creation of slash and debris, the RPF may propose and, with the concurrence of the Director's representative, delete those areas within 300 ft. not visible from roads or watercourses when such requirements are not necessary to reduce fire hazards, to maintain soil fertility, to reduce erosion and to improve visual appearance.

(b) Burning: Broadcast burning shall be prohibited on lands harvested under the commercial thinning and selection silvicultural methods in Coastal Zone Special Treatment Areas. Broadcast burning may be allowed for site preparation purposes in accordance with 14 CCR 917.4 on lands harvested under the clearcut, rehabilitation or sanitation-salvage methods when a prescribed burning plan is submitted as part of the Timber Harvesting Plan which explains and justifies broadcast burning in the Coastal Commission Special Treatment Areas. A determined effort shall be made to protect the surface organic horizon of the soil during the cause of any permitted broadcast burning operations.

(c) Snags: All snags within the Watercourse and Lake Protection Zone and within 100 feet (30.48 m) of meadow edges shall be left standing with the following exceptions:

(1) When felling is required for fire or safety reasons, as specified by the rules or CAL OSHA regulations, or when necessary in sanitation-salvage operations.

(2) When a snag of commercial value is marked for felling by an RPF or supervised designee after an initial preharvest inspection and consultation with DFG and the timber owner.

961.6 Hazard Reduction [C.C. Special Treatment Area]

There shall be no broadcast burning within Coastal Commission Special Treatment Areas. Piles surrounded by a firebreak may be burned, provided the burning is confined to the individual pile, and is in a location and conducted in a manner that will not damage the residual trees or reproduction. An exception may be approved by the Director when a prescribed burning plan is submitted as part of the plan which explains and justifies broadcast burning in the Coastal Commission Special Treatment Areas.

921.7 Watercourse and Lake Protection [C.C. Special Treatment]

Watercourse and lakeside vegetation shall be protected and remain standing to the degree necessary to protect scenic and natural qualities and protect the beneficial uses of water. In addition to the requirements of 14 CCR 916 through 916.9, Coastal Commission Special Treatment Area Watercourse and Lake Protection Zones adjacent to clearcuts or rehabilitation cutting shall be at least 150 feet on each side of Class I or II waters.

CALIFORNIA FOREST PRACTICE RULES

961.7 Watercourse and Lake Protection [Southern, Special Treatment Area]

Watercourse and lakeside vegetation shall be protected and remain standing to the degree necessary to protect scenic and natural qualities and protect the beneficial uses of water. In addition to the requirements of 14 CCR 956 through 956.8 the following standards shall apply in the Coastal Commission Special Treatment Areas. The Watercourse and Lake Protection Zone shall be 150 feet on each side of Class I watercourses and lakes, and 100 feet on each side of Class II watercourses.

921.8 Buffer Zones Within the Coastal Zone [Coastal Zone]

The following additional rules shall apply to buffer zones within Coastal Scenic View Corridors and adjacent to publicly owned preserves and recreation areas as defined and/or designated by the Coastal Commission on July 5, 1977.

The buffer zone adjacent to designated Coastal highways shall be a 200 ft. (60.96 m) wide band running parallel to the first line of trees nearest the road on appropriate side(s) of the road as designated. In no place shall the buffer zone extend more than 350 feet (106.68 m) from the shoulder of the road. The buffer zone also shall include those forested areas within the Coastal Zone within 200 ft. (60.96 m) of a publicly owned preserves and recreation areas including national, state, regional, county, and municipal parks. Said distances shall be measured along the surface of the ground.

(a) The clear-cutting or rehabilitation silvicultural method is prohibited within the designated buffer zones, and a well distributed stand of trees shall be left within said buffer zones upon completion of timber operations, except under exceptional circumstances. Such exceptions shall be explained and justified in the plan and found in conformance by the Director when the proposed exceptions conform to the goals outlined in 14 CCR 921.

(b) Logging roads, tractor roads, and skid trails and landings shall be screened from direct view to the extent feasible by leaving trees and vegetation between the disturbed area and public areas where the disturbance would be visible to substantial numbers of viewers.

961.8 Buffer Zones Within the Coastal Zone [CZ, Southern]

A 200 feet (60.96 m) buffer zone shall be established adjacent to the boundaries of all publicly owned preserves and recreation areas within the Coastal Zone where the following restrictions shall apply:

(a) The use of the clear-cut silvicultural method is prohibited.

(b) A well distributed stand of trees shall be left within the buffer zone. The leave tree requirements of the commercial thinning or selection method shall be met or exceeded immediately following completion of timber operations.

(c) Roads, landing, and cuts and fills shall be screened from direct view by leaving screen trees and other vegetation between the disturbed areas and public areas utilized by substantial numbers of viewers.

921.9 Alternatives [Coast, CZ]

The RPF may propose alternative to the requirements of this article on a site specific basis. The RPF must explain and justify the proposed alternative in the THP. Alternative measures stated in the plan shall be so written as to provide clear, enforceable standards for the guidance of the timber operator. The Director may approve such alternative provided the alternative practice will achieve equal protection for each of the goals of Section 921 and protection at least equal to that which would result from using measures stated in Section 921.1-921.8. The Director shall not accept for inclusion in a THP any alternative practice as described in this section where two or more agencies listed in 4582.6 of the PRC and 14 CCR 1037.3 have submitted written comments which lead to the Director's conclusion that the proposed alternative will not meet the intent of the Act and rules and the agencies participated in the review of the plan, including any on-the-ground inspection.

Article 12 Logging Roads and Landings [Article 11. Northern]

923, 943, 963 Logging Roads and Landings [All Districts]

All logging roads and landings in the logging area shall be planned, located, constructed, reconstructed, used, and maintained in a manner which: is consistent with long-term enhancement and maintenance of the forest resource; best accommodates appropriate yarding systems, and economic feasibility; minimizes damage to soil resources and fish and wildlife habitat; and prevents degradation of the quality and beneficial

CALIFORNIA FOREST PRACTICE RULES

uses of water. The provisions of this article shall be applied in a manner which complies with this standard.

Factors that shall be considered when selecting feasible alternatives (see 14 CCR 897 and 898) shall include, but are not limited to, the following:

- (a) Use of existing roads whenever feasible.
- (b) Use of systematic road layout patterns to minimize total mileage.
- (c) Planned to fit topography to minimize disturbance to the natural features of the site.
- (d) Avoidance of routes near the bottoms of steep and narrow canyons, through marshes and wet meadows, on unstable areas, and near watercourses or near existing nesting sites of threatened or endangered bird species.
- (e) Minimization of the number of watercourse crossings.
- (f) Location of roads on natural benches, flatter slopes and areas of stable soils to minimize effects on watercourses.
- (g) Use of logging systems which will reduce excavation or placement of fills on unstable areas.

923.1, 943.1, 963.1 Planning for Roads and Landings [All Districts]

The following standards for logging roads and landings shall be adhered to:

- (a) All logging roads shall be located and classified on the THP map as permanent, seasonal, or temporary. Road failures on existing roads which will be reconstructed shall also be located on the THP map. In addition to the requirements of 14 CCR 1034(x), the probable location of those landings which require substantial excavation or which exceed one quarter acre in size, shall be shown on the THP map.
- (b) New logging roads shall be planned in accordance with their classification and maintenance requirements.
- (c) Logging roads and landings shall be planned and located, when feasible, to avoid unstable areas. The Director shall approve an exception if those areas are unavoidable, and site-specific measures to minimize slope instability due to construction are described and justified in the THP.
- (d) Where roads and landings will be located across 100 feet or more of lineal distance on any slopes over 65% or on slopes over 50% which are within 100 ft. of the boundary of a WLPZ, measures to minimize movement of soil and the discharge of concentrated surface runoff shall be incorporated in the THP. The Director may waive inclusion of such measures where the RPF can show that slope depressions, drainage ways, and other natural retention and detention features are sufficient to control overland transport of eroded material. The Director may require end-hauling of material from areas within 100 ft. of the boundary of a WLPZ to a stable location if end hauling is feasible and is necessary to protect water quality. The Director shall require maintenance provisions in the THP for drainage structures and facilities provided that such maintenance is feasible and necessary to keep roadbeds and fills stable.
- (e) New logging roads shall not exceed a grade of 15% except that pitches of up to 20% shall be allowed not to exceed 500 continuous feet (152.4 m). These percentages and distances may be exceeded only where it can be explained and justified in the THP that there is no other feasible access for harvesting of timber or where in the Northern or Southern Districts use of a gradient in excess of 20% will serve to reduce soil disturbance.
- (f) Roads and landings shall be planned so that an adequate number of drainage facilities and structures are installed to minimize erosion on roadbeds, landing surfaces, sidecast and fills.
- (g) Unless exceptions are explained and justified in the THP, general planning requirements for roads shall include:
 - (1) Logging roads shall be planned to a single-lane width compatible with the largest type of equipment used in the harvesting operation with turnouts at reasonable intervals.
 - (2) Roads shall be planned to achieve as close a balance between cut volume and fill volume as is feasible.
 - (3) When roads must be planned so that they are insloped and ditched on the uphill side, drainage shall be provided by use of an adequate number of ditch drains.
- (h) Road construction shall be planned to stay out of Watercourse and Lake Protection Zones. When it is a better alternative for protection of water quality or other forest resources, or when such roads are the only feasible access to timber, exceptions may be explained and justified in the THP and shall be agreed to by the Director if they meet the requirements of this subsection.
- (i) **[Coast]** The location of all logging roads to be constructed shall be flagged or otherwise identified on

CALIFORNIA FOREST PRACTICE RULES

the ground before submission of a THP or major amendment. Exceptions may be explained and justified in the THP and agreed to by the Director if flagging is unnecessary as a substantial aid to examining: (1) compatibility between road location and yarding and silvicultural systems, or (2) possible significant adverse effects of road location on water quality, soil productivity, wildlife habitat, or other special features of the area.

(i) **[Northern, Southern]** All logging roads to be constructed shall be flagged or otherwise identified on the ground before submission of a THP or, substantial deviation, except for temporary roads less than 600 ft. in length that would meet the requirements for a minor deviation (see 14 CCR 1036, 1039, 1040) if they were submitted as such. Exceptions may be explained and justified in the THP and agreed to by the Director if flagging or other identification is unnecessary as a substantial aid to examining: (1) compatibility between road location and yarding and silvicultural systems or (2) possible significant adverse effects of road location on water quality, soil productivity, wildlife habitat, or other special features of the area.

(j) If logging roads will be used from the period of October 15 to May 1, hauling shall not occur when saturated soil conditions exist on the road.

923.2, 943.2, 963.2 Road Construction [All Districts]

Logging roads shall be constructed or reconstructed in accordance with the following requirements or as proposed by the RPF, justified in the THP, and found by the Director to be in conformance with the requirements of this Article.

(a) Logging roads shall be constructed in accordance with the approved THP. If a change in designation of road classification is subsequently made, the change shall be reported in accordance with 14 CCR 1039 or 1040, as appropriate.

(b) Where a road section which is greater than 100 feet in length crosses slopes greater than 65%, placement of fill is prohibited and placement of sidecast shall be minimized to the degree feasible. The Director may approve an exception where site specific measures to minimize slope instability, soil erosion, and discharge of concentrated surface runoff are described and justified in the THP.

(c) On slopes greater than 50%, where the length of road section is greater than 100 ft., and the road is more than 15 ft. wide (as measured from the base of the cut slope to the outside of the berm or shoulder of the road) and the fill is more than 4 ft. in vertical height at the road shoulder for the entire 100 feet the road shall be constructed on a bench that is excavated at the proposed toe of the compacted fill and the fill shall be compacted. The Director may approve exception to this requirement where on a site-specific basis if the RPF has described and justified an alternative practice that will provide equal protection to water quality and prevention of soil erosion.

(d) **[Coast]** Fills, including through fills across watercourses shall be constructed in a manner to minimize erosion of fill slopes using techniques such as insloping through-fill approaches, waterbars, berms, rock armoring of fill slopes, or other suitable methods.

(d) **[Northern, Southern]** Roads shall be constructed so no break in grade, other than that needed to drain the fill, shall occur on through fill; breaks in grade shall be above or below the through fill, as appropriate. Where conditions do not allow the grade to break as required, through fills must be adequately protected by additional drainage structures or facilities.

(e) Through fills shall be constructed in approximately one foot lifts.

(f) On slopes greater than 35 percent, the organic layer of the soil shall be substantially disturbed or removed prior to fill placement. The RPF may propose an exception in the THP and the Director may approve the exception where it is justified that the fill will be stabilized.

(g) Excess material from road construction and reconstruction shall be deposited and stabilized in a manner or in areas where downstream beneficial uses of water will not be adversely affected.

(h) Drainage structures and facilities shall be of sufficient size, number and location to carry runoff water off of roadbeds, landings and fill slopes. Drainage structures or facilities shall be installed so as to minimize erosion, to ensure proper functioning, and to maintain or restore the natural drainage pattern. Permanent watercourse crossings and associated fills and approaches shall be constructed where feasible to prevent diversion of stream overflow down the road and to minimize fill erosion should the drainage structure become plugged.

CALIFORNIA FOREST PRACTICE RULES

(i) Where there is evidence that soil and other debris is likely to significantly reduce culvert capacity below design flow, oversize culverts, trash racks, or similar devices shall be installed in a manner that minimizes culvert blockage.

(j) Waste organic material, such as uprooted stumps, cull logs, accumulations of limbs and branches, and unmerchantable trees, shall not be buried in road fills. Wood debris or cull logs and chunks may be placed and stabilized at the toe of fills to restrain excavated soil from moving downslope.

(k) Logging roads shall be constructed without overhanging banks.

(l) Any tree over 12 inches (30.5 cm) d.b.h. with more than 25% of the root surface exposed by road construction, shall be felled concurrently with the timber operations.

(m) Sidecast or fill material extending more than 20 ft. (6.1 m) in slope distance from the outside edge of the roadbed which has access to a watercourse or lake which is protected by a WLPZ shall be seeded, planted, mulched, removed, or treated as specified in the THP, to adequately reduce soil erosion.

(n) All culverts at watercourse crossings in which water is flowing at the time of installation shall be installed with their necessary protective structures concurrently with the fill, construction and reconstruction of logging roads. Other permanent drainage structures shall be installed no later than October 15. For construction and reconstruction of roads after October 15, drainage structures shall be installed concurrently with the activity.

(o) Drainage structures and drainage facilities on logging roads shall not discharge on erodible fill or other erodible material unless suitable energy dissipators are used. Energy dissipators suitable for use with waterbreaks are described in 14 CCR 914.6(f) [934.6(f), 954.6(f)].

(p) Where roads do not have permanent and adequate drainage, the specifications of Section 914.6 [934.6, 954.6] shall be followed.

(q) Drainage facilities shall be in place and functional by October 15. An exception is that waterbreaks do not need to be constructed on roads in use after October 15 provided that all such waterbreaks are installed prior to the start of rain that generates overland flow.

(r) No road construction shall occur under saturated soil conditions, except that construction may occur on isolated wet spots arising from localized ground water such as springs, provided measures are taken to prevent material from significantly damaging water quality.

(s) Completed road construction shall be drained by outsloping, waterbreaks and/or cross-draining before October 15. If road construction takes place from October 15 to May 1, roads shall be adequately drained concurrent with construction operations.

(t) Roads to be used for log hauling during the winter period shall be, where necessary, surfaced with rock in depth and quantity sufficient to maintain a stable road surface throughout the period of use. Exceptions may be proposed by the RPF, justified in the THP, and found by the Director to be in conformance with the requirements of this subsection.

(u) Slash and other debris from road construction shall not be bunched against residual trees which are required for silvicultural or wildlife purposes, nor shall it be placed in locations where it could be discharged into Class I or II watercourses.

(v) Road construction activities in the WLPZ, except for stream crossings or as specified in the THP, shall be prohibited.

923.3, 943.3, 963.3 Watercourse Crossings [All Districts]

Watercourse crossing drainage structures on logging roads shall be planned, constructed, reconstructed, and maintained or removed, according to the following standards. Exceptions may be provided through application of Fish and Game Code Sections 1601 and 1603 and shall be included in the THP.

(a) The location of all new permanent watercourse crossing drainage structures and temporary crossings located within the WLPZ shall be shown on the THP map. If the structure is a culvert intended for permanent use, the minimum diameter of the culvert shall be specified in the plan. Extra culverts beyond those shown in the THP map may be installed as necessary.

(b) The number of crossings shall be kept to a feasible minimum.

(c) Drainage structures on watercourses that support fish shall allow for unrestricted passage of all life stages of fish that may be present, and shall be fully described in the plan in sufficient clarity and detail to allow evaluation by the review team and the public, provide direction to the LTO for implementation, and provide enforceable standards for the inspector.

CALIFORNIA FOREST PRACTICE RULES

(d) When watercourse crossings, other drainage structures, and associated fills are removed the following standards shall apply:

(1) Fills shall be excavated to form a channel that is as close as feasible to the natural watercourse grade and orientation, and that is wider than the natural channel.

(2) The excavated material and any resulting cut bank shall be sloped back from the channel and stabilized to prevent slumping and to minimize soil erosion. Where needed, this material shall be stabilized by seeding, mulching, rock armoring, or other suitable treatment.

(e) All permanent watercourse crossings that are constructed or reconstructed shall accommodate the estimated 100-year flood flow, including debris and sediment loads.

(f) Permanent watercourse crossings and associated fills and approaches shall be constructed or maintained to prevent diversion of stream overflow down the road and to minimize fill erosion should the drainage structure become obstructed. The RPF may propose an exception where explained in the THP and shown on the THP map and justified how the protection provided by the proposed practice is at least equal to the protection provided by the standard rule.

(g) Any new permanent culverts installed within class I watercourses shall allow upstream and downstream passage of fish or listed aquatic species during any life stage and for the natural movement of bedload to form a continuous bed through the culvert and shall require an analysis and specifications demonstrating conformance with the intent of this section and subsection.

(h) The amendments to 14 CCR §§ 923.3 [943.3, 963.3] that became effective July 1, 2000 shall expire on December 31, 2002.

923.4, 943.4, 963.4 Road Maintenance [All Districts]

Logging roads, landings, and associated drainage structures used in a timber operation shall be maintained in a manner which minimizes concentration of runoff, soil erosion, and slope instability and which prevents degradation of the quality and beneficial uses of water during timber operations and throughout the prescribed maintenance period. In addition those roads which are used in connection with stocking activities shall be maintained throughout their use even if this is beyond the prescribed maintenance period.

(a) The prescribed maintenance period for erosion controls on permanent and seasonal roads and associated landings and drainage structures which are not abandoned in accordance with 14 CCR 923.8 [943.8, 963.8] shall be at least one year. The Director may prescribe a maintenance period extending up to three years in accordance with 14 CCR 1050.

(b) Upon completion of timber operations, temporary roads and associated landings shall be abandoned in accordance with 14 CCR 923.8 [943.8, 963.8].

(c) Waterbreaks shall be maintained as specified in 14 CCR 914.6 [934.6, 954.6].

(d) Unless partially blocked to create a temporary water source, watercourse crossing facilities and drainage structures, where feasible, shall be kept open to the unrestricted passage of water. Where needed, trash racks or similar devices shall be installed at culvert inlets in a manner which minimizes culvert blockage. Temporary blockages shall be removed by November 15.

(e) Before the beginning of the winter period, all roadside berms shall be removed from logging roads or breached, except where needed to facilitate erosion control.

(f) Drainage structures, if not adequate to carry water from the fifty-year flood level, shall be removed in accordance with 14 CCR 923.3(d) [943.3(d), 963.3(d)] by the first day of the winter period, before the flow of water exceeds their capacity if operations are conducted during the winter period, or by the end of timber operations whichever occurs first. Properly functioning drainage structures on roads that existed before timber operations need not be removed. An RPF may utilize an alternative practice, such as breaching of fill, if the practice is approved by the Director as providing greater or equal protection to water quality as removal of the drainage structure.

(g) Temporary roads shall be blocked or otherwise closed to normal vehicular traffic before the winter period.

(h) During timber operations, road running surfaces in the logging area shall be treated as necessary to prevent excessive loss of road surface materials by, but not limited to, rocking, watering, chemically treating, asphaltting or oiling.

(i) Soil stabilization treatments on road or landing cuts, fills, or sidecast shall be installed or renewed, when such treatment could minimize surface erosion which threatens the beneficial uses of water.

CALIFORNIA FOREST PRACTICE RULES

- (j) Drainage ditches shall be maintained to allow free flow of water and minimize soil erosion.
- (k) Action shall be taken to prevent failures of cut, fill, or sidecast slopes from discharging materials into watercourses or lakes in quantities deleterious to the quality or beneficial uses of water.
- (l) Each drainage structure and any appurtenant trash rack shall be maintained and repaired as needed to prevent blockage and to provide adequate carrying capacity. Where not present, new trash racks shall be installed if there is evidence that woody debris is likely to significantly reduce flow through a drainage structure.
- (m) Inlet and outlet structures, additional drainage structures (including ditch drains), and other features to provide adequate capacity and to minimize erosion of road and landing fill and sidecast to minimize soil erosion and to minimize slope instability shall be repaired, replaced, or installed wherever such maintenance is needed to protect the quality and beneficial uses of water.
- (n) Permanent watercourse crossings and associated approaches shall be maintained to prevent diversion of stream overflow down the road should the drainage structure become plugged. Corrective action shall be taken before the completion of timber operations or the drainage structure shall be removed in accordance with 14 CCR Section 923.3(d) [943.3(d), 963.3(d)].
- (o) Except for emergencies and maintenance needed to protect water quality, use of heavy equipment for maintenance is prohibited during wet weather where roads or landings are within a WLPZ.
- (p) The Director may approve an exception to a requirement set forth in subsections (b) through (o) above when such exceptions are explained and justified in the THP and the exception would provide for the protection of the beneficial uses of water or control erosion to a standard at least equal to that which would result from the application of the standard rule.

923.5, 943.5, 963.5 Landing Construction [All Districts]

Landings shall be constructed according to the following standards:

- (a) On slopes greater than 65%, no fill shall be placed and sidecast shall be minimized to the degree feasible. The Director may approve an exception if, site specific measures to minimize slope instability, soil erosion, and discharge of concentrated surface runoff are described and justified in the THP.
- (b) On slopes greater than 50%, fills greater than 4 ft. in vertical height at the outside shoulder of the landing shall be: 1) constructed on a bench that is excavated at the proposed toe of the fill and is wide enough to compact the first lift, and 2) compacted in approximately 1 ft. lift from the toe to the finished grade. The RPF or supervised designee shall flag the location of this bench or the RPF shall provide a description of the bench location (narrative or drawing) in the THP for fills meeting the above criteria, where the length of landing section is greater than 100 feet. The RPF may propose an exception in the THP and the Director may approve the exception where it is justified that the landing will be stabilized.
- (c) Waste organic material, such as uprooted stumps cull logs, accumulations of limbs and branches, or unmerchantable trees, shall not be buried in landing fills. Wood debris or cull logs and chunks may be placed and stabilized at the toe of landing fills to restrain excavated soil from moving downslope.
- (d) Constructed landings shall be the minimum in width, size, and number consistent with the yarding and loading system to be used. Landings shall be no larger than one-half acre (.202 ha) unless explained and justified in the THP.
- (e) No landing construction shall occur under saturated soil condition.
- (f) The following specifications shall be met upon completion of timber operations for the year or prior to October 15, whichever occurs first:
 - (1) Overhanging or unstable concentrations of slash, woody debris and soil along the downslope edge or face of the landings shall be removed or stabilized when they are located on slopes over 65% or on slopes over 50% within 100 ft. of a WLPZ.
 - (2) Any obstructed ditches and culverts shall be cleaned.
 - (3) Landings shall be sloped or ditched to prevent water from accumulating on the landings. Discharge points shall be located and designed to reduce erosion.
 - (4) Sidecast or fill material extending more than 20 feet in slope distance from the outside edge of the landing and which has access to a watercourse or lake shall be seeded, planted, mulched, removed or treated as specified in the THP to adequately reduce soil erosion.
 - (5) Sidecast or fill material extending across a watercourse shall be removed in accordance with standards for watercourse crossing removal set forth in 14 CCR 923.3 (d).

CALIFORNIA FOREST PRACTICE RULES

(g) On slopes greater than 35%, the organic layer of the soil shall substantially removed prior to fill placement.

(h) When landings are constructed after October 15 they shall be adequately drained concurrent with construction operations and shall meet the requirements of (f)(1) through (f)(4) of this subsection upon completion of operations at that landing.

(i) The RPF may propose and the Director may approve waiver of requirements in (f)(1) through (f)(4) of this subsection if the Director finds they are not necessary to minimize erosion or prevent damage to downstream beneficial uses. The Director may also approve an exception to the October 15th date for treatment of slash and debris, including the practice of burning.

923.6, 943.6, 963.6 Conduct of Operations on Roads and Landings [All Districts]

Routine use and maintenance of roads and landings shall not take place when, due to general wet conditions, equipment cannot operate under its own power. Operations may take place when roads and landings are generally firm and easily passable or during hard frozen conditions. Isolated wet spots on these roads or landings shall be rocked or otherwise treated to permit passage. However, operations and maintenance shall not occur when sediment discharged from landings or roads will reach watercourses or lakes in amounts deleterious to the quality and beneficial uses of water. This section shall not be construed to prohibit activities undertaken to protect the road or to reduce erosion.

923.7, 943.7, 963.7 Licensed Timber Operator Responsibility for Roads and Landings [All Districts]

The licensed timber operator who is responsible for the implementation or execution of the plan shall not be responsible for the construction and maintenance of roads and landings, unless the licensed timber operator is employed for that purpose.

923.8, 943.8, 963.8 Planned Abandonment of Roads, Watercourse Crossings, and Landings [All Districts]

Abandonment of roads, watercourse crossings and landings shall be planned and conducted in a manner which provides for permanent maintenance-free drainage, minimizes concentration of runoff, soil erosion and slope instability, prevents unnecessary damage to soil resources, promotes regeneration, and protects the quality and beneficial uses of water. General abandonment procedures shall be applied in a manner which satisfies this standard and include the following:

(a) Blockage of roads so that standard production four wheel-drive highway vehicles cannot pass the point of closure at the time of abandonment.

(b) Stabilization of exposed soil on cuts, fills, or sidecast where deleterious quantities of eroded surface soils may be transported in a watercourse.

(c) Grading or shaping of road and landing surfaces to provide dispersal of water flow.

(d) Pulling or shaping of fills or sidecast where necessary to prevent discharge of materials into watercourses due to failure of cuts, fills, or sidecast.

(e) Removal of watercourse crossings, other drainage structures, and associated fills in accordance with 14 CCR 923.3(d). Where it is not feasible to remove drainage structures and associated fills, the fill shall be excavated to provide an overflow channel which will minimize erosion of fill and prevent diversion of overflow along the road should the drainage structure become plugged.

The Director may approve an exception to a requirement set forth in (b) through (e) above when such exceptions are explained and justified in the THP and the exception would provide for the protection of the beneficial uses of water or control erosion to a standard at least equal to that which would result from the application of the standard rule.

923.9, 943.9, 963.9 Roads and Landings in Watersheds with Threatened or Impaired Values [All Districts]

In addition to all other district Forest Practice Rules, the following requirements shall apply in any planning watershed with threatened or impaired values:

(a) Where logging road or landing construction or reconstruction is proposed, the plan shall state the locations of and specifications for road or landing abandonment or other mitigation measures to minimize the adverse effects of long-term site occupancy of the transportation system within the watershed.

CALIFORNIA FOREST PRACTICE RULES

(b) Unless prohibited by existing contracts with the U.S.D.A. Forest Service or other federal agency, new and reconstructed logging roads shall be no wider than a single-lane compatible with the largest type of equipment specified for use on the road, with adequate turnouts provided as required for safety. The maximum width of these roads shall be specified in the plan. These roads shall be outsloped where feasible and drained with water breaks or rolling dips (where the road grade is inclined at 7 percent or less), in conformance with other applicable Forest Practice Rules.

(c) The following shall apply on slopes greater than 50%:

(1) Specific provisions of construction shall be identified and described for all new roads.

(2) Where cutbank stability is not an issue, roads may be constructed as a full-benched cut (no fill). Spoils not utilized in road construction shall be disposed of in stable areas with less than 30 percent slope and outside of any WLPZ, EEZ, or ELZ.

(3) Alternatively, roads may be constructed with balanced cuts and fills if properly engineered, or fills may be removed with the slopes recontoured prior to the winter period.

(d) In addition to the provisions listed under 14 CCR 923.1(e) [943.1(e), 963.1(e)], all permanent or seasonal logging roads with a grade of 15% or greater that extends 500 continuous feet or more shall have specific erosion control measures stated in the plan.

(e) Where situations exist that elevate risks to the values set forth in 14 CCR 916.2(a), [936.2(a), 956.2(a)] (e.g., road networks are remote, the landscape is unstable, water conveyance features historically have a high failure rate, culvert fills are large) drainage structures and erosion control features shall be oversized, low maintenance, or reinforced, or they shall be removed before the completion of the timber operation. The method of analysis and the design for crossing protection shall be included in the plan.

(f) The provisions of 14 CCR 923.9 [943.9, 963.9] shall not apply to a plan that is subject to an incidental take permit based upon an approved Habitat Conservation Plan that addresses anadromous salmonid protection.

(g) This section shall expire on December 31, 2002.

Article 13 County Rules

924 County Rules Within the Southern Subdistrict of the Coast Forest District [Coast, SSD]

In lieu of 14 CCR 1032.7 subsections (c), (e), (f), (g), and (h)(1) and 1037, the rules contained in 924.1 through 924.5 shall apply in any county for which rules have been adopted pursuant to PRC 4516.5.

924.1 Plan Submittal and Notice of Intent [Coast, SSD]

(a) The plan submitter shall prepare and submit to the Director, with the plan, a Notice of Intent to Harvest Timber as described in 14 CCR 1032.7(d).

(b) The plan submitters shall furnish to the Department at the time of submission of the plan the names and addresses of an property owners within 300 ft. of the exterior boundaries of assessor's parcels upon which a plan has been submitted, and the names and addresses of property owners with property fronting or bordering that portion of the haul route lying between the plan area and the nearest public road. The list shall be compiled from the latest equalized assessment roll of the county or a list provided by a title insurance company.

(1) The plan submitter shall submit business size envelopes stamped with first class postage properly addressed to the property owners identified in (b). These will be used by the Department for mailing the Notice of Filing.

(c) The plan submitter shall mail copies of the Notice of Intent to all names in (b) prior to plan submission. At the time of plan submission, the plan submitter shall certify in writing that this procedure has been followed.

(d) For plan amendments, the submitter of the amendment shall certify in writing at the time the amendment is submitted that copies of a new Notice of Intent have been mailed to:

(1) All property owners not previously noticed under subsection (b) who, because of the plan amendment, would be required to receive the notice provided for in subsection (b).

(2) All property owners previously noticed under subsection (b) when there is a change in silvicultural method.

CALIFORNIA FOREST PRACTICE RULES

924.2 Plan Filing [Coast, SSD]

A plan found by the Director to be accurate, complete and in proper order shall be filed on the 10th day following the date of its receipt by the Department. When the Director finds a plan inaccurate, incomplete, or otherwise not in proper order, the plan shall be returned to the submitter with written specifications of the deficiencies.

924.3 Preharvest Inspection [Coast, SSD]

On or before the date the plan is filed, the Director shall determine if a preharvest inspection is necessary. A preharvest inspection shall be conducted on all plans for which a public hearing is to be held.

924.4 Notice of Filing [Coast, SSD]

In addition to those items required by 14 CCR 1037.1, the following shall apply:

- (a) The Notice of Filing shall contain:
 - (1) The date, time and location of the public hearing, when applicable.
 - (2) The Director shall include the date, time and location of the review team meeting if it is known.
- (b) Within two working days of the date the plan is filed, the Director shall send copies of the Notice of

Filing to:

- (1) All property owners listed in 14 CCR 924.1(b).
- (2) A newspaper of general distribution in the area.

924.5 Agency and Public Review [Coast, SSD]

In addition to the requirements of 14 CCR 1037.3, the following shall apply: The Director shall send a copy of the filed plan to any local public water agency that makes written request for it and the appropriate local school district.

COUNTY RULES, COAST DISTRICT

925 Santa Clara County Rules [Santa Clara County]

In addition to forest practice rules applying in the Coast Forest District and Southern Subdistrict of the Coast Forest District, rules contained in 925.1 to 925.10 shall apply within the boundaries of Santa Clara County. These rules are for all of Santa Clara County, including that portion in the Southern Forest District. Where the general rules conflict with Santa Clara County rules, the Santa Clara County rules shall apply.

925.1 Winter Period [Santa Clara County]

The winter period for Santa Clara County shall be October 15 through April 15.

925.2 Plan Submittal and Notice of Intent [Santa Clara County]

14 CCR 1032.7 subsections (c), (e), (f), (g), and (h)(1), shall not apply in Santa Clara County. In lieu of those subsections, the following shall apply:

- (a) The plan submitter shall prepare and submit to the Director, with the plan, a Notice of Intent to Harvest Timber as described in 14 CCR 1032.7(d).
- (b) The plan submitter shall furnish to the Department at the time of submission of the plan the names and addresses of all property owners within 300 ft. of the exterior boundaries of assessor's parcels upon which a plan has been submitted, and the names and addresses of property owners with property fronting or bordering that portion of the haul route lying between the plan area and the nearest public road. The list shall be compiled from the latest equalized assessment roll of the county or a list provided by a title insurance company.
- (c) The plan submitter shall mail copies of the Notice of Intent to all names in (b) prior to plan submission. At the time of plan submission, the plan submitter shall certify in writing that this procedure has been followed.
- (d) For plan amendments, the submitter of the amendment shall certify in writing at the time the amendment is submitted that copies of a new Notice of Intent have been mailed to:

CALIFORNIA FOREST PRACTICE RULES

(1) All property owners not previously noticed under subsection (b) who, because of the plan amendment, would be required to receive the notice provided for in subsection (b).

(2) All property owners previously noticed under subsection (b) when there is a change in silvicultural method.

925.3 Plan Distribution [Santa Clara County]

Within two working days of the date of the receipt of the plan, the Director shall transmit copies of the plan to:

- (a) The local school district within which the plan is located.
- (b) The Santa Clara Valley Water District.

925.4 Contents of the Plan [Santa Clara County]

14 CCR 1034, subsection (g) and that portion of (x) pertaining to map size shall not apply in Santa Clara County (all of subsections (x)(1) through (x)(14) shall apply.). In lieu of those subsections, the following shall apply:

(a) A description of the plan area within which timber operations are to be conducted. The description shall include the following:

- (1) U.S. Geological Survey (USGS) Quadrangle name(s) and date(s),
- (2) township, range, and section number(s),
- (3) county name(s),
- (4) CALWATER 2.2 planning watershed number(s),
- (5) approximate acreage, and
- (6) assessor's parcel number(s) for the assessor's parcels within which a plan is submitted.

(b) The estimated number of logging truck loads to be removed and the approximate number of daily trips.

(c) The following information shall be clearly provided on a reproducible 1" = 500' topographic map showing 40 ft. contour intervals, provided such maps are available from the county at nominal cost. Additional maps may be required to show specific details, and may be planimetric. Color coding shall not be used. A legend shall be included indicating the meaning of the symbols used. See district rules for the appropriate minimum mapping acreages.

(1) The location of scenic roads as designated by the County General Plan or in another document officially adopted by the county.

(2) Location of all structures (including mobile homes or trailers) currently maintained for human habitation within 200 ft. as measured along the surface of the ground from the boundary of the plan area.

(d) On timber operations requiring submission of a plan, all routes to be used for removing forest products from the plan area to the mill or county line shall be shown on a road map submitted with the plan. A proposed change in the use of public roads that are part of the haul route shall be presumed to be a substantial deviation unless the plan submitter requests that the proposed change be considered a minor deviation in accordance with the procedures set forth in 14 CCR 1036 and 1040 and the Director so determines. The Director shall consult with County Transportation Agency before giving approval.

(e) A statement shall be prepared indicating the proposed type, quantity, purpose and method of application of any chemicals listed as restricted by the State Department of Food and Agriculture that are to be used.

925.5 Tractor Yarding [Santa Clara County]

In addition to 14 CCR 914.2, the following shall apply in Santa Clara County. Prior to submittal of a plan, the location of proposed constructed tractor roads on slopes over 50% shall be intervisibly flagged on the ground.

925.6 Flagging [Santa Clara County]

In addition to other flagging requirements in Subchapter 3 of Title 14 CCR, the Director, where necessary to protect adjoining properties, may require flagging of approximate property lines on the site where any truck road, tractor road or harvest area is proposed within 100 ft. of a property line.

CALIFORNIA FOREST PRACTICE RULES

925.7 Log Hauling [Santa Clara County]

(a) Log hauling on public roads is not permitted on Saturdays, Sundays, or on those days which are nationally designated legal holidays.

(b) Log hauling on public roads may be restricted or not permitted by the Director during commute hours or during school busing hours in order to prevent a serious hazard to traffic flow and safety or to prevent hazardous conditions that would endanger school children.

(c) During log hauling on public roads, the timber operator may be required by the Director to post special traffic signs and/or flagmen where determined to be necessary to prevent a hazard to traffic.

(d) Any new access for the use of logging trucks to Highway 17 shall not be constructed until the Director has received approval for such construction from the State Department of Transportation and has consulted with the County Transportation Agency. A request for newly constructed access must be accompanied by evidence that such access will not adversely impact traffic flow and safety on the highway.

925.8 Public Road Buffer Zone [Santa Clara County]

All logging roads, tractor roads, and landings located within 200 ft. as measured along the surface of the ground from the edge of the traveled surface of a public road, shall be screened from direct public view to the extent feasible by leaving trees and vegetation between disturbed areas and public road. If trees are to be harvested in this buffer zone, the proposed harvesting shall be identified in the plan and the trees to be cut or left shall be marked before the preharvest inspection, if such an inspection is to be made.

925.9 Public Road Protection [Santa Clara County]

All proposed construction activities for logging roads and associated drainage structures, tractor roads, or other activities involving significant earth movement within 200 ft. of a public road shall be described in the plan. The construction of logging roads and associated drainage structures, tractor roads, or other activities involving significant earth movement within 200 feet of a public road is prohibited if the Director has determined that the activities will significantly increase the maintenance costs of the public road or result in damage to the public road which will significantly restrict the use of the public road.

925.10 Hours of Work [Santa Clara County]

Within 300 ft. of any occupied dwelling, the operation of power equipment except licensed highway vehicles, shall be restricted to the hours between 7:00 a.m. and 7:00 p.m., and shall be prohibited on Saturdays, Sundays and nationally designated legal holidays. An exception to this rule may be granted by the Director where he/she has found that no disturbance will result to the occupants of the dwelling from the use of such equipment.

925.11 Performance Bonding [Santa Clara County]

When hauling logs pursuant to a THP, the LTO shall provide for the repair of any damage to a county road that is willfully or negligently caused by the LTO's log hauling operations, and shall provide for the repair of any damage caused by the LTO's log hauling operations to appurtenant structures, including, but not limited to, guard rails, signs, traffic signals, culverts, curbs and similar facilities. If necessary to ensure compliance with this section, the county may request, and the Department, upon such request, may require the timber operator or responsible party to post adequate financial security to restore paved or unpaved county roads and appurtenant structures which are damaged by log hauling operations. The request for posting of financial security shall be made to the Department during the THP review procedure and no later than five days before the Director's decision date. The timber operator or responsible party shall post a certificate of deposit, certificate of insurance or performance bond, or other financial security in favor of the Department in a reasonable amount set by the Director, not to exceed \$5,000 per mile of county road used or \$50,000, whichever is less and subject to provisions of Div. 3, Part I, Chapter 1, Article 8, Sec. 11110 through 11113 of the Gov. C. Such cash deposit or other acceptable financial security shall cover a period not to exceed the effective period of the plan.

When a form of financial security is required, logging trucks shall not use the county roads until the required security is posted with the Department. The Director shall release the bond or equivalent to the principal of the security upon completion of log hauling operations and compliance with the requirements of this section. If and when repairs are necessary, the Director shall request the operator to provide for making

CALIFORNIA FOREST PRACTICE RULES

the repairs. If the repairs are not made the Department may take corrective action and may order the bond, or equivalent, forfeited in an amount not to exceed actual damage. When a bond or equivalent has been posted, the Department shall provide the county with a copy of the Work Completion Report. The county shall advise the Department in writing within 30 days of its receipt of notification of completion of hauling operations or the Work Completion Report if damage has occurred repairs need to be made. If the county fails to notify the Director within 30 days, the bond of surety shall be released.

926 Santa Cruz County Rules [Santa Cruz County]

In addition to forest practice rules applying in the Coast Forest District and Southern Subdistrict of the Coast Forest District, rules contained in 926.1. through 926.19 shall apply within the boundaries of Santa Cruz County. Where the general rules conflict with Santa Cruz County rules, the Santa Cruz County rules shall apply.

926.1 Registered Professional Forester (RPF) Advice [Santa Cruz County]

The provisions of 14 CCR 913.8(b)(5) shall apply when timber operations are conducted in accordance with 14 CCR 926.25.

926.2 Field Review and Timber Operator Certification [Santa Cruz County]

Subsequent to plan approval, but prior to commencement of timber operations, the RPF responsible for preparing the plan, the RPF who will advise the timber operator during timber operations (if different), and the timber operator shall meet in the field to review the specifics of the plan. The Director may attend and participate in such meeting, and shall be given advance notice of the meeting by the plan submitter. After such meeting and prior to commencement of timber operations, or upon the filing of any subsequent major amendment to the plan, the licensed timber operator shall execute and file with the Department a written certification that such timber operator or a supervised designee familiar with on-site conditions actively participated in a field review, is familiar with all state and local rules applicable to the proposed timber operation including without limitation the requirements of Section 1035.2 and 1035.3, understands the plan or such major amendment and each of the conditions that have been placed upon the plan or such major amendment by the Department as part of the review process, and is familiar with, and acknowledges the responsibility to communicate this information to those persons hired to carry out the proposed timber operation under his/her direction. The term "supervised designee" means any representative whose activities are controlled by the LTO in the same manner that an RPF would control the activities of a "supervised designee" as defined in 14 CCR 895.1.

926.3 Plan Submittal and Notice of Intent [Santa Cruz County]

14 CCR 1032.7, subsections (c), (e), (f), and (g), shall not apply in Santa Cruz County. In lieu of those subsections, the following shall apply:

(a) The plan submitter shall prepare and submit to the Director, with the plan, a Notice of Intent to Harvest Timber as described in 14 CCR 1032.7(d) which shall additionally include the following:

(1) A statement that the approximate property lines have been flagged for review where truck roads, tractor roads or harvest areas are within 100 feet of the property line.

(2) In the event helicopter yarding is proposed, the Notice of Intent will include a map that clearly identifies the areas within the proposed timber harvest plan area that are proposed for helicopter operations, including helicopter log landing and service area sites and a statement about the approximate duration of helicopter yarding activities.

(b) The plan submitter shall furnish to the Department at the time of submission of the plan, the names and addresses of all property owners within 300 ft. of the exterior boundaries of assessor's parcels upon which a plan has been submitted, the names and addresses of property owners with property fronting or bordering that portion of the haul route lying between the plan area and the nearest public road, and the addresses of all private road association members. "Private road association" as used in this section and all other rules specific to Santa Cruz County shall mean those road associations appearing on a list maintained by the County and provided to the Director which are either a County Service Area which maintains any private road or any other private road association that has recorded by-laws or other organizing instruments recorded in the official records of Santa Cruz County from which it can be ascertained the assessor parcel

CALIFORNIA FOREST PRACTICE RULES

numbers of the properties owned by the members. If helicopter yarding is proposed, the list shall also include the names and addresses of property owners with property located within three thousand (3,000) feet of any location in the proposed timber harvest area in which logs are to be picked up, carried, or landed, or helicopters are to use for servicing. It is the intent of the notice provisions of this paragraph to direct the notice to both owners and residents of properties lying within the 3,000 foot notice area; accordingly if any property owner to be noticed by mail on a proposed helicopter yarding has a mailing address located outside of the three thousand foot notice area and such property owner's property within such area has a street address within such area, the list shall also contain the street address of the property within the three thousand (3,000) foot radius, and shall list the addressee at such property as "Occupant." The list shall be compiled from the latest equalized assessment roll of the county or a list provided by a title insurance company. Any list prepared for noticing an operation with helicopter yarding shall be deemed accurate provided that it contains accurate information regarding at least 95% of the property owners and situs addresses entitled to notice under these Rules based upon the County Tax Assessor's records.

(c) The plan submitter shall mail copies of the Notice of Intent to all property owners and members of those private road associations on the list provided by the County identified pursuant to (b) at least 10 days prior to plan submission and at this time shall post a copy of the Notice of Intent including a map as described in 14 CCR 1032.7 (d)(8) at a conspicuous location on the private road where a majority of the road association members can view the notice and, if helicopter yarding is proposed, at a minimum of one conspicuous location every half mile on all public roads within a 2 mile radius of the proposed area of operations. The posted Notice of Intent shall be on colored paper or identified with colored flagging so as to be easily visible to the public. The plan submitter shall further mail the Notice of Intent to:

(1) All members of the Board of Supervisors in whose district any timber operation is proposed;

(2) The local school district;

(3) Any local publicly-owned water district or community water system which maintains any water production or water storage facility downstream from any location within which any timber operation is proposed. At the time of plan submission, the plan submitter shall certify to the Director in writing that this procedure has been followed.

(d) The plan submitter shall have the Notice of Intent published in a newspaper of general circulation in the area, concurrently with the submission of the plan to the Director. Proof of publication of notice shall be provided to the Director prior to his/her determination made pursuant to 14 CCR 1037.6.

(e) For plan amendments, the submitter of the amendment shall certify in writing at the time the amendment is submitted that copies of a new Notice of Intent have been mailed to:

(1) All property owners not previously noticed under subsection (b) who, because of the plan amendment, would be required to receive the notice provided in subsection (b).

(2) All property owners previously noticed under subsection (b) when there is a change in silvicultural method.

(f) The plan submitter shall include with the mailed Notice of Intent sent to the persons identified above, other than members of the Board of Supervisors, local school district or publicly-owned water district or community water systems, any available printed general informational material that has been jointly approved by the County of Santa Cruz and the Department, describing the review process and the rights of adjacent landowners and other neighbors under applicable rules, ordinances or statutes.

(g) The RPF shall simultaneously file with the Department any notice of deviation given to the plan submitter or landowner required under Public Resources Code section 4583.2.

(h) In the event the Director shall approve a timber harvest plan which provides in whole or in part for helicopter yarding and where such harvest operations are not commenced within the same harvest season in which the plan is approved, the plan submitter shall, not less than 14 days prior to the estimated commencement of helicopter operations and not more than 28 days prior to the estimated commencement of such operations:

(1) Mail a notice to all persons previously notified of the Notice of Intent of the original application or any amendment under (b) above, providing notice of the fact that the helicopter yarding was approved, containing a map showing the location of the harvest areas, landing area, and service area approved in the Plan, the hours of operation, the estimated starting date of helicopter yarding activities, the

CALIFORNIA FOREST PRACTICE RULES

estimated completion date, and any conditions placed on the helicopter yarding activity by the Director as part of the approval; and

(2) Post a copy of the notice at a minimum of one conspicuous location every half mile on all public roads within a 2 mile radius of the proposed area of operations. The posted notice shall be on colored paper or identified with colored flagging so as to be easily visible to the public.

(3) The plan submitter shall further mail the notice to those persons identified in 14 CCR 926.3(c)(1),(2).

(4) Prior to commencement of helicopter operations, the plan submitter shall certify to the Director in writing that these procedures have been followed.

926.4 Preharvest Inspection Report [Santa Cruz County]

Following any preharvest inspection, the Forest Practice Officer who conducted the inspection shall make a written report on the plan, indicating whether the plan, as proposed, conforms to the requirements of the Forest Practice Act and Board rules, and further stating whether the feasibility analysis required by 14 CCR 898 has properly responded to the issues identified in that section. A copy of this Preharvest Inspection Report shall be provided to review team members and advisors, and shall be made available for public information as a public record.

926.5 Additional Information After Preharvest Inspection [Santa Cruz County]

When the Director determines, based upon field inspection of the plan area, that additional information is necessary in order that the Review Team may conduct the review prescribed by 14 CCR 1037.5(b), the RPF who prepared the plan shall be responsible for supplying such additional information. Additional information shall be limited to information regarding those items specified in 14 CCR 1034, Contents of Plan.

926.6 Public Water Agency Representative [Santa Cruz County]

In the case of any timber operation proposed to be carried out in an area which serves as a watershed for any publicly-owned water purveyor, the Director shall request a representative of such water purveyor to assist the Department as an advisor in the review process, pursuant to the provisions of 14 CCR 1037.5; such water purveyor representative shall be permitted to participate in all review team meetings.

926.7 Review Team Field Review [Santa Cruz County]

Any review team member may, on request, accompany the Department as an advisor to the Department, on any field review the Department conducts prior to approval of the plan. A member of the review team shall have five working days following the date of the review team meeting in which to file any notice of non-concurrence provided for in 14 CCR 1037.5(e).

When a proposed timber harvest area is adjacent to a residential neighborhood; when the only access to the proposed timber harvest area is through neighboring property; or when multi-owner private road(s) are to be used for hauling; the residents of the adjacent neighborhood or the owners of the private road(s) may designate one person as their representative to attend the pre-harvest inspection and all Review Team field inspections and meetings that are scheduled. The Director and plan submitter shall be provided with written notice of the designated representative's name, address and telephone number. Such person may only enter the property of the landowner where the harvest is proposed with the consent of the landowner. Such person shall be entitled to receive advance notice of the time and place of the pre-harvest inspection and Review Team field reviews, may make inquiries of the review team members, but shall not be a member of the Review Team.

926.8 Fuelwood Operations [Santa Cruz County]

Notwithstanding 14 CCR 1038(b), the harvest of fuelwood in operations where more than three acres are proposed to be harvested, shall be carried out in accordance with the provisions of 14 CCR 1038-1038.1. In addition, for purposes of 14 CCR 1038, minimum impact means:

- (a) No new road construction;
- (b) No road reconstruction that involves substantial change in the original road prism;
- (c) No timber operations on slopes in excess of 60%;

CALIFORNIA FOREST PRACTICE RULES

- (d) No timber operations in special treatment areas;
- (e) No timber operations within watercourse and lake protection zones;
- (f) No timber operations on unstable soils;
- (g) No timber operations within 500 feet on an active nesting site of rare or endangered bird species;
- (h) No timber operations on areas with high or extreme erosion hazard rating;
- (i) The harvest area must be immediately stocked; and
- (j) Timber operations are limited to 45 days unless an approved plan is obtained.

Fuelwood operations that cannot be harvested pursuant to 14 CCR 1038 and 1038.1 will require a plan pursuant to 14 CCR 913.8(b).

926.9 Hours of Work [Santa Cruz County]

(a) Except as provided in paragraph (b) below, the operation of chain saws and other power-driven equipment shall be restricted to the hours between 7:00 a.m. and 7:00 p.m., and shall be prohibited on Saturdays, Sundays, and nationally designated legal holidays. An exception to this rule may be granted by the Director where s/he has found that no disturbance will result from the use of such equipment.

(b) Within 300 feet of any occupied legal dwelling, the operation of chain saws and all other power equipment, except licensed highway vehicles, shall be restricted to the hours between 8:00 a.m. and 6:00 p.m., and shall be prohibited on Saturdays, Sundays and nationally designated legal holidays. The Director may grant an exception to allow operations between 7:00 a.m. and 7:00 p.m. within 300 feet of residences if a determination of no disturbance can be made based upon the occupant(s) agreement to a written request submitted by the RPF to the Director before plan approval.

(c) When it is anticipated that there will be staging of licensed vehicles outside the plan submitter's property between the hours of 9:00 p.m. and 7:00 a.m., the RPF shall provide an operating plan which reduces noise impacts to nearby residences.

926.10 Log Hauling [Santa Cruz County]

(a) Log hauling on public roads is not permitted on Saturdays, Sundays, or on those days which are nationally designated legal holidays.

(b) Log hauling on public roads, or private roads may be restricted or not permitted by the Director during commute hours or during school busing hours when necessary to prevent a serious hazard to traffic flow and safety or to prevent hazardous conditions that would endanger public safety.

(c) During log hauling on public roads, or on private roads the timber operator may be required by the Director to post special traffic signs and/or flagpersons where determined to be necessary to prevent a hazard to traffic.

926.11 Flagging of Property Lines [Santa Cruz County]

The RPF or his/her supervised designee shall, prior to plan submission to the Department, flag the approximate property lines of the timberland owner's parcel on the site where any truck road, tractor road or harvest area is proposed within 100 feet of a property line.

926.12 Soil [Santa Cruz County]

The process of constructing or reconstructing truck roads, tractor roads, tractor trails, and landings shall not cause soil to be deposited on property owned by others, except with the consent of the property owner.

926.13 Performance Bonding [Santa Cruz County]

When hauling logs pursuant to a THP, the LTO shall provide for the repair of any damage to a county road that is willfully or negligently caused by the LTO's log hauling operations, or to a private road that is caused by the LTO's log hauling operations, and shall provide for the repair of any damage caused by the LTO's log hauling operations to appurtenant structures including, but not limited to, guard rails, signs, traffic signals, culverts, curbs and similar facilities. If necessary to ensure compliance with this section, the county, owner(s)/easement holder(s) of private road or private road association may request, and the Department, upon such request, may require the timber operator or responsible party to post adequate financial security to restore paved or unpaved county or private roads and appurtenant structures which are damaged by log hauling operations. The request for posting of financial security shall be made to the Department during the

CALIFORNIA FOREST PRACTICE RULES

THP review procedure and no later than five days before the Director's decision date. The timber operator or responsible party shall post a certificate of deposit, certificate of insurance or performance bond, or other financial security in favor of the Department in a reasonable amount set by the Director, not to exceed \$5,000 per mile of road used or \$50,000, whichever is less and subject to provisions of Division 3, Part I, Chapter 1, Article 8, Sections 11110 through 11113 of the Government Code. Such cash deposit or other acceptable financial security shall cover a period not to exceed the effective period of the plan. When a form of financial security is required, logging trucks shall not use the roads until the required security is posted with the Department. The Director shall release the bond or equivalent to the principal of the security upon completion of log hauling operations and compliance with the requirements of this section. If and when repairs are necessary, the Director shall request the operator to provide for making the repairs. If the repairs are not made, the Department may take corrective action and may order the bond, or equivalent, forfeited in an amount not to exceed actual damage. When a bond or equivalent has been posted, the Department shall provide the county with a copy of the Work Completion Report. The county shall advise the Department in writing within 30 days of its receipt of notification of completion of hauling operations or the Work Completion Report if damage has occurred, repairs need to be made. If the county fails to notify the Director within 30 days, the bond or surety shall be released.

926.14 Biotic Resources [Santa Cruz County]

In addition to the requirements of 14 CCR 1034(w), the plan shall identify local unique plant and animal species as identified in the Santa Cruz County General Plan.

926.15 Road Construction [Santa Cruz County]

Whenever new road construction is proposed and the plan submitter owns or controls any property contiguous to the parcel or parcels on which timber operations are proposed, and such contiguous property contains timberland, the RPF shall include a map and explanation of how the new road is integrated into the existing or proposed truck road and associated transportation system for all the contiguous property owned or controlled by the plan submitter on which timberland is found. Such proposed integrated truck road and associated transportation system shall be reviewed in connection with review of the proposed plan, and the plan shall be modified, if necessary, to assure that the approved plan will be compatible and consistent with timber operations on the contiguous property.

926.16 Flagging [Santa Cruz County]

The location of proposed truck roads, constructed tractor roads, landings, and watercourse crossings shall be designated on the plan map and shall be located in the field with flagging. Such flagging shall occur prior to the preharvest inspection if one is to be conducted. Flagging for truck roads and constructed tractor roads will be intervisible along the proposed alignments.

926.17 Abandonment of Roads and Landings [Santa Cruz County]

When an existing truck road, tractor road, or landing is located in an area in which it could not be newly constructed in conformance with these rules, then, where feasible, such road or landing shall be abandoned, stabilized, revegetated, and restricted from vehicular use, unless the use of such road or landing would produce less environmental impact than the use of a new road or landing constructed in accordance with these rules.

926.18 Winter Period [Santa Cruz County]

The winter period for Santa Cruz County shall be October 15 through April 15.

926.19 Erosion Control Maintenance [Santa Cruz County]

The plan submitter shall maintain all drainage structures, drainage facilities and gating or other devices to prevent access required by these rules in effective working condition throughout one winter period after completion of timber operations unless other stricter measures are required under the Forest Practice Rules. Skid trails, landings and work areas shall be reseeded, mulched or protected by compacting slash and debris from harvest operation. The Director may require further measures to prevent unnecessary damage to road surfaces from unauthorized use and to protect the quality and beneficial uses of water. The County

CALIFORNIA FOREST PRACTICE RULES

representative responsible for review of timber harvests shall receive advanced notice and may attend the work completion inspection with the Department to review erosion control measures. A work completion report may not be filed until this requirement has been met.

926.21 Exemptions From Timber Harvesting Plan Requirements [Santa Cruz County]

The following requirements shall apply to timber operations conducted on ownerships of timberland of less than three acres pursuant to 14 CCR 1038(c).

(a) The notice of exemption submitted to the Director pursuant to 14 CCR 1038.1 shall be accompanied by a planimetric or topographic map that clearly shows the location of and identifies the following features within the plan area:

- (1) Log landing proposed to be used,
- (2) Tractor roads on slopes over 50%,
- (3) Logging roads,
- (4) Watercourses, lakes, marshes, springs, and seeps, and
- (5) Structures, including mobile homes and trailers, currently maintained for human habitation

within 200 ft., as measured along the surface of the ground, from the boundary of the plan area.

(b) In addition, the following information shall be provided:

- (1) The approximate number of trees to be cut,
- (2) Assessor's Parcel Number covering the plan area,
- (3) Zoning designation covering the plan area, and
- (4) Expected dates of commencement and completion.

(c) Within 5 working days of receipt, CDF shall determine whether the exemption is complete and accurate. If it is found to be complete and accurate, CDF shall send a copy with a Notice of Acceptance to both the county and the applicant. Operations pursuant to the Exemption may not commence for ten working days from the date of the Notice of Acceptance in order to provide the County with an opportunity to: (1) review the proposed operation, and (2) notify the submitter of applicable county regulations prior to the onset of operations. The Notice of Acceptance shall include the following statements:

(1) An explanation that both the state and county have regulatory authority over timber harvest operations on ownerships of timberland of less than three acres.

(2) An explanation that the Director's acceptance only relates to compliance with the rules of the State Board of Forestry [*and Fire Protection*].

(3) Recommendation that the submitter should consult with the Santa Cruz Planning Department before proceeding.

(4) Notification that proceeding without consulting with the County Planning Department could result in violation of county ordinances.

(5) Notification that operations pursuant to the Exemption may not commence for ten working days to facilitate review of this operation by the county. The earliest date on which operations may commence shall be clearly stated in the Notice of Acceptance.

(d) If the Exemption is determined to be incomplete, CDF shall return the exemption to the applicant with a cover letter explaining the deficiencies.

926.23 Contents of Plan [Santa Cruz County]

In addition to 14 CCR 1034 the following shall apply in Santa Cruz County:

(a) When log hauling is proposed over non-appurtenant private roads, the RPF shall provide:

(1) Information substantiating the timber owner's legal right to access or use said private road(s).

(2) A statement as to the estimated number of total logging truck loads to be removed and the approximate number of haul days and location of proposed logging truck staging areas.

(3) A statement as to how obligations to maintain the road shall be satisfied commensurate with use.

(4) Specific measures which provide for the safe use of the road, such as flag persons, signage, pilot cars and hours of restriction.

(5) Videotape, photograph or other means of documentation for noting the existing conditions of the road.

(b) The RPF shall provide a map showing the location of the flagged property boundaries along with any documentation that substantiates the property line.

CALIFORNIA FOREST PRACTICE RULES

(c) The description of the plan area shall include the County Assessor Parcel Number(s) for those parcel(s) within which timber operations are to be conducted.

(d) The RPF shall include within the notice to the landowner section of the plan the following statement: "Section 16.22.030 of the County Code states that any road or bridge constructed pursuant to a Timber Harvest Permit [*sic: Plan*] issued by the State of California, if used to serve purposes other than forest management activities shall be considered new and shall be subject to all County design standards and applicable policies including County grading and bridge permits."

926.25 Special Harvesting Methods [Santa Cruz County]

In addition to 14 CCR 913.8 subsection (a), the harvesting limitation, re-entry period and leave tree standards shall be modified as follows:

(a) The cutting standards are as follows:

(1) For areas where the proposed harvest rate is 51-60% of the trees greater than 45.7 cm (18 in.) d.b.h., the minimum re-entry period shall be 14 years.

(2) For areas where the proposed harvest is 50% or less of the trees greater than 45.7 cm (18 in.) d.b.h., a 10 year re-entry period shall apply.

(3) Regardless of re-entry period, no more than 40% of the trees greater than 35.6 cm. (14 in.) and less than 45.7 cm (18 in.) d.b.h. shall be harvested.

927 Marin County Rules [Marin County]

In addition to forest practice rules applying in the Coast Forest District and Southern subdistrict of the Coast Forest District, rules contained in 927.1 through 927.17 shall apply within the boundaries of Marin County. Where the general rules conflict with Marin County rules, the Marin County rules shall apply.

927.1 Winter Period [Marin County]

The winter period for Marin County shall be October 1 through April 15.

927.2 Contents of Plan [Marin County]

All of subsections (x)(1) through (x)(14) of 14 CCR 1034 shall apply in Marin County. Subsection (g) and that portion of (x) pertaining to map size shall not apply and in lieu of those subsections, the following shall apply:

(a) A description of the plan area within which timber operations are to be conducted. The description shall include the following:

(1) U.S. Geological Survey (USGS) Quadrangle name(s) and date(s),

(2) township, range, and section number(s),

(3) county name(s),

(4) CALWATER 2.2 planning watershed number(s),

(5) approximate acreage, and

(6) assessor's parcel number(s) for the assessor's parcels within which a plan is submitted.

(b) The estimated number of logging truck loads to be removed and the approximate number of daily trips.

(c) The following information shall be clearly provided on a reproducible 1"=500' topographic map showing 40 ft. contour intervals, provided such maps are available from the county at nominal cost.

(Nominal cost for the purposes of this subsection shall not exceed \$10.) If this map is not available, the map requirement in 14 CCR 1034(x) shall apply. Additional maps may be required to show specific details, and may be planimetric. Color coding shall not be used. A legend shall be included indicating the meaning of the symbols used. See district rules for the appropriate minimum mapping acreage.

(1) Location of Marin County Recreation Corridor (CRC), scenic corridors, conservation zones, as identified in the Marin Countywide Plan of April, 1982 and special treatment areas designated by the County General Plan of 1982 or in any other document officially adopted by the county.

(2) Location of all structures (including mobile homes or trailers) currently maintained for human habitation within 200 ft. as measured along the surface of the ground from the boundary of the plan area.

(d) On timber operations requiring submission of a plan, all routes to be used for removing forest products from the plan area to the mill or county line shall be shown on a road map submitted with the plan. A

CALIFORNIA FOREST PRACTICE RULES

proposed change in the use of public roads that are part of the haul route shall be presumed to be a substantial deviation unless the plan submitter requests that the proposed change be considered a minor deviation in accordance with the procedure set forth in 14 CCR 1036 and 1040 and the Director so determines. The Director shall consult with County Transportation District before giving approval. The plan shall identify the location of schools along the haul route and shall specify their hours of operation.

(e) Plan maps must show the location of and identify the following: all log landings proposed to be used, and all main tractor roads on slopes over 50%, all logging roads, all watercourses, lakes, and marshes and boundaries of the CRC within or contiguous to the plan area.

(f) A statement shall be prepared indicating the proposed type, quantity, purpose and method of application of any chemicals listed as restricted by the State Department of Food and Agriculture that are to be used.

(g) The plan shall include a brief statement describing any additional proposed uses for the land in addition to timber harvesting (e.g., a residential or commercial development) for a period of five years.

(h) Whenever new road construction is proposed and the plan submitter owns or controls any property contiguous to the parcel or parcels on which timber operations are proposed, and such contiguous property contains timberland, the RPF shall include a map and explanation of how the new road is integrated into the existing or proposed truck road and associated transportation system, for all the contiguous property owned or controlled by the plan submitter on which timberland is found. Such proposed integrated truck road and associated transportation system shall be reviewed in connection with review of the proposed plan, and the plan shall be modified, if necessary, to assure that the approved plan will be compatible and consistent with timber operations on the contiguous property.

(i) The THP shall include a plan for safe access to a public roadway from the site of operations. The plan submitter shall be required to consult with County officials in designing the access plan, and shall attach to the THP a County encroachment permit if one has been approved.

(j) The plan submitter shall identify any publicly owned water purveyor within the drainage and indicate on the plan whether a watershed protection agreement with any publicly owned water purveyor has been obtained for the proposed operation and append any such agreement to the plan. Any such agreement shall be appended for information purposes only. If no such agreement has been reached with the water purveyor, the plan submitter shall attach any previous correspondence to and from the water purveyor concerning the proposed timber operation.

(k) If a road or landing to be constructed or improved as part of the proposed timber operation is planned to be used to serve or facilitate a residential or commercial development, the plan submitter shall obtain a grading permit from the county and attach any such permit to the plan, for information purposes only.

927.3 Tractor Yarding [Marin County]

In addition to 14 CCR 914.2, the following shall apply in Marin County: Prior to submittal of a plan, the approximate location of proposed constructed tractor roads on slopes over 50% shall be intervisibly flagged on the ground.

927.4 Flagging [Marin County]

In addition to flagging requirements in Subchapter 3 of Title 14 CCR, the Director, where necessary to protect adjoining properties, may require flagging of approximate property lines on the site where any truck road, tractor road or harvest area is proposed within 100 ft of a property line.

927.5 Log Hauling [Marin County]

(a) Log hauling on public roads is not permitted on Saturdays, Sundays, or on those days which are nationally designated holidays.

(b) Log hauling on public roads shall be restricted or not permitted by the Director during commute hours or during school busing hours if necessary to prevent a significant hazard to traffic flow and safety or to prevent hazardous conditions that would endanger public safety.

(c) During log hauling on public roads, the timber operator may be required by the Director to post special traffic signs and/or flagpersons where determined to be necessary to prevent a hazard to traffic.

(d) Any new access for the use of logging trucks on Highway 1 shall not be constructed until the Director has received approval for such construction from the State Department of Transportation and has consulted with the County Transportation District. A request for newly constructed access must be accompanied by

CALIFORNIA FOREST PRACTICE RULES

evidence that such access will not adversely affect traffic flow and safety on the highway.

(e) Where road width will not permit passage of a logging truck and another oncoming vehicle, and adequate turnouts are not present, the Director may require the use of pilot cars equipped with warning signs and flashing lights to guide logging trucks on public roads.

(f) Within 300 ft. of any occupied dwelling, the operation of power equipment, including chain saws, except licensed highway vehicles, shall be restricted to the hours between 7:00 a.m. and 7:00 p.m., and shall be prohibited on Saturdays, Sundays, and nationally designated legal holidays. Where, because of unusual ground condition or very close proximity of occupied dwellings or special circumstances related thereto, the Director determines that a need exists for further restrictions, he/she may increase the distance and may limit the hours to not less than 8:00 a.m. to 5:00 p.m. An exception to this rule may be granted by the Director where he/she has found that no disturbance will result to the occupants of the dwelling from the use of such equipment.

927.6 Public Road Buffer Zone [Marin County]

All logging roads, tractor roads, and landings located within 200 ft., as measured along the surface of the ground from the edge of the traveled surface of a public road, shall be screened from direct public view to the extent feasible by leaving trees and vegetation between disturbed areas and public roads. If trees are to be harvested in this buffer zone, the proposed harvesting shall be identified in the plan and the trees to be cut or left shall be marked before the preharvest inspection, if such an inspection is to be made.

927.7 Timber Harvesting Plans [Marin County]

(a) An initial inspection of the area in which timber operations are to be conducted shall be made within 10 days from the date of filing of the plan, or such longer period as may be mutually agreed upon by the Director and the person submitting the plan. The RPF who prepared the plan shall attend the initial inspection.

(b) In the case of any timber operation proposed to be carried out in an area which serves as a watershed for any publicly owned water purveyor, the Director shall request a representative of such water purveyor to assist the Department as a advisor in the review process, pursuant to the provision of 14 CCR 1037.5; such water purveyor representative shall be permitted to participate in all review team meetings.

927.8 Exemptions from Timber Harvesting Plan Requirements [Marin County]

To ensure that the protection necessary to maintain the integrity of the resources of the County are achieved, the following requirements shall apply to the timber operations exempt from filing of THPs under 14 CCR 1038:

(a) The requirements of 14 CCR 927.7(a) and (b), and 927.2(c) and (e) shall apply with the following exceptions:

(1) Pursuant to PRC 4582.7, an initial inspection may not be required;

(2) A written plan is not required although a plan map must accompany the notice of timber operations. Harvesting of Christmas trees is exempt from timber marking requirements.

(b) The expected dates of commencement and completion shall be stated in the notice of timber operations.

(c) The Director shall acknowledge in writing and within 10 days, acceptance or rejection of the notice of timber operations. The Director shall consult with the Marin County Planning Director before acceptance. Timber operations shall not commence until the Director's acceptance has been received by the person who filed the notice.

(d) Exempt operations shall be limited to the calendar year of acceptance.

(e) The requirements of PRC 4585, Completion Report, and PRC 4587, Stocking Reports, shall apply to exempt operations within the County.

927.9 Silvicultural Methods and Intermediate Treatments [Marin County]

The objective of this section is to prescribe silvicultural methods and treatments that will protect the long-term productivity of soils and timberlands and protect the natural and scenic qualities of the County. The following silvicultural methods and treatments as prescribed below will be applied in the County. 14 CCR 913 through 913.6 defines these methods and treatments.

CALIFORNIA FOREST PRACTICE RULES

(a) Commercial Thinning Intermediate Treatment or the Selection Method: When the commercial thinning treatment or the selection silvicultural method is used, the following standards are required:

(1) Leave a well distributed timber stand after cutting and logging operations have been completed on the cut area. Leave at least 40% by number of those trees 18 in. or more d.b.h. which were present prior to commencement of current timber operations and at least 50% by number of those over 12 in. d.b.h. but less than 18 in. or more d.b.h.. Leave trees 18 in. or more d.b.h. shall be dominant or codominant in crown class prior to timber harvesting or have crowns typical of such dominant or codominant trees. All leave trees shall be thrifty coniferous trees which are free from substantial damage caused by timber operations. No conifer tree shall be cut which is more than 75 ft. from a leave tree 12 inches d.b.h. or larger located within the logging area. Average top stump diameter, outside bark, shall be considered 1 in. greater than d.b.h.

(2) Immediately following completion of timber operations, stocking must meet or exceed stocking standards of 14 CCR 927.10.

(3) A report of stocking as described in PRC 4587 shall be filed within six months following completion of work as described in the plan.

(b) Sanitation-Salvage Treatment: When the sanitation-salvage treatment is used, the following practices are required:

(1) Restrictions on time periods for subsequent timber operations shall not apply to the sanitation-salvage treatment.

(2) An effort shall be made to regenerate any cut area during the first planting season following log removal. Necessary site preparation, planting, or seeding shall be completed within the first planting season following logging, except where unusual or adverse weather conditions require extending site preparation and planting into the following planting season. Deficiencies in stocking shall be corrected by planting annually at least three times if necessary to meet the stocking standards in 14 CCR 927.10.

(c) Clearcutting Method: The clearcutting method is not authorized for the County.

(d) Recutting of Logging Areas: Timber operations for removal of trees may only be repeated on a logging area within less than ten years after completion of a previous timber operation if minimum standards have been met, the reasons for the operation are justified and explained in the plan and the scenic and/or natural qualities of a stand would be enhanced by lighter or more frequent tree removal. In no instance shall stocking be reduced below the standards provided in 14 CCR 927.10 nor shall more than 60% by numbers of those trees 18 in. and more d.b.h. and no more than 50% by numbers of those trees over 12 in. d.b.h. but less than 18 in. d.b.h. be removed within any one 10-year period.

On timber operations in which cutting has occurred within 10 years preceding the current operations, stumps which are the result of cutting trees within the preceding 10 years shall be counted as trees cut during the current operation in determining percent of trees cut. Timber operations conducted under the Sanitation-Salvage Treatment, and the harvesting of minor forest products and incidental vegetation are exempt from the above provision of this section.

927.10 Stocking Requirements [Marin County]

The stocking standards for understocked timberlands and substantially damaged timberlands as provided for by 14 CCR 1080 through 1081.1 and 1085 through 1085.6 are not applicable in the County. After completion of timber operations one of the following stocking standards must be met:

(a) Basal Area: The average residual basal area, measured in stems 1 in. or larger in diameter shall be at least 125 sq. ft. per acre on Site I lands, at least 100 sq. ft. per acre on Site II and Site III lands and at least 75 sq. ft. per acre on Site IV and V lands, or

(b) Point Count: The area contains an average point count as specified below:

(1) On Site I and II lands, the area contains an average point count of 450 per acre to be computed as follows:

(A) 450 countable trees per acre not more than 4 inches d.b.h.; each tree to count as one towards meeting stocking requirements.

(B) 150 countable trees per acre over 4 in. d.b.h. and not more than 12 in. d.b.h.; each tree to count as three toward meeting stocking requirements.

(C) 75 countable trees per acre over 12 in. d.b.h.; each tree to count as six toward meeting stocking requirements.

CALIFORNIA FOREST PRACTICE RULES

(2) On Site III, IV and V lands the area contains an average point count of 300 per acre to be computed as follows:

(A) 300 countable trees per acre not more than 4 inches d.b.h.; each tree to count as one toward meeting stocking requirements.

(B) 100 countable trees per acre over 4 inches d.b.h. and not more than 12 inches d.b.h.; each tree to count as 3 towards meeting stocking requirements.

(C) 50 countable trees per acre over 12 in. d.b.h.; each tree to count as six toward meeting stocking requirements.

Redwood root crown sprouts will be counted using the average stump diameter 1 ft. above average ground level of the original stump from which the redwood root crown sprouts originate, counting one sprout for each 1 ft. of stump diameter to a maximum of six per stump. Site classification shall be determined by the forester (RPF) who prepared the plan. Rock outcroppings, meadows, wet areas, or other areas not normally bearing timber shall not be considered as requiring stocking and are exempt from such provisions.

927.11 Logging Practices [Marin County]

The following logging practices shall be adhered to:

(a) Roads: Rules contained in 14 CCR 923 through 923.2 shall be adhered to with the following special requirements:

(1) Roads shall be single lane, and generally the traveled surface shall be no more than 12 ft. in width, except where alignment, safety, and equipment necessary to conduct the operation requires additional width. Deviations shall be explained and justified in the plan.

(2) Roads, landings, cuts, and fills shall be screened from direct view to the extent feasible by leaving screen trees and other vegetation between the disturbed areas and public areas utilized by substantial numbers of viewers.

(b) Soil disturbance, other than that incident to necessary road maintenance, whether with tractor or by cable means, shall not occur under excessively wet ground conditions that could result in substantial soil compaction and erosion.

(c) Notwithstanding the requirements of 14 CCR 1040, if in construction rock outcroppings, springs, and other physical factors require a change in roads, landings, and tractor road locations, the location can be changed with the concurrence of the RPF, the operator, and the Director's representative, provided that such changes in location constitute minor deviations. The RPF shall provide written confirmation of such minor deviations which shall become a part of the plan. All changes in location constituting substantial deviations shall be submitted to the Director as amendments to the plan.

(d) Felling Practices: Up to 10% of the trees that are proposed for cutting may be substituted one for one with those proposed to be left uncut provided that the leave tree proportion, size class, distribution, and general forest appearance of the residual stand as approved in the preliminary field work is preserved. Justification for the substitution standard shall be based on unavoidable tree damage, safety factors, lean of trees, location of obstructions or roads or openings insufficient to accommodate felled trees.

(e) The process of constructing or reconstructing truck roads, tractor roads, and landings shall not cause soil to be deposited on property owned by others, except with the consent of the property owner.

(f) The plan submitter shall maintain all drainage structures and drainage facilities required by these rules in effective working condition throughout one winter period after completion of timber operations. A work completion report may not be filed until this requirement has been met.

927.12 Hazard Reduction [Marin County]

(a) Burning: Broadcast burning shall be prohibited on lands harvested under the commercial thinning treatment and selection silvicultural methods in the County. Broadcast burning may be allowed for site preparation purposes in accordance with 14 CCR 917.4 on lands harvested under the sanitation-salvage treatment when a prescribed burning plan is submitted as part of the Timber Harvesting Plan which explains and justifies broadcast burning in the County. An effort shall be made to protect the surface organic horizon of the soil during the course of any permitted broadcast burning operations.

(b) Snags: All snags within the Watercourse and Lake Protection Zone and within 100 ft. of meadow edges shall be left standing with the following exceptions:

CALIFORNIA FOREST PRACTICE RULES

(1) When felling is required for fire or safety reasons (CAL OSHA regulations, 8 CCR 6259) or when necessary in sanitation-salvage operations.

(2) When a snag of commercial value is marked for felling by the RPF after an initial preharvest inspection and consultation with the Department of Fish and Game and the timber owner.

927.13 Buffer Zones Within the CRC [Marin County]

The following additional rules shall apply to buffer zones within Marin County Recreation Corridor:

The buffer zone adjacent to designated coastal highways shall be a 200 ft. wide band running parallel to the first line of trees nearest the road on appropriate side(s) of the road as designated. In no place shall the buffer zone extend more than 350 ft. from the shoulder of the road.

A buffer zone of 200 ft. shall also run adjacent to all publicly owned preserves and recreation areas including national, state, regional, county, and municipal parks. Said distance shall be measured along the surface of the ground.

Logging roads, tractor roads, and skid trails and landings shall be screened from direct view to the extent feasible by leaving trees and vegetation between the disturbed area and vista points that would attract viewers.

927.14 Notice of Intent and Filing [Marin County]

In addition to 14 CCR 924.1(b) and 924.4(b) the Notice of Intent and Filing of THP applications shall be provided to the appropriate publicly owned water purveyor and to any school district or private school on the haul route excluding those portions of Highway 101.

927.15 Review Team Meetings [Marin County]

In addition to 14 CCR 1037.5, the following provisions shall govern public participation in the review of timber harvesting plans in Marin County:

(a) A written response by the Department and Fire Protection to issues raised that are pertinent to the THP in question shall be made available to the public before the final approval or disapproval of the THP. The issues raised must be received by the Department before the date for decision on the THP and may be either oral or written.

(b) Review team recommendations shall be made available at the CDF or county planning department office for public comment prior to the final decision.

(c) Any review team member and any qualified technical expert designated by a review team member may, on request, accompany the Department as a advisor to the Department, on any field review the Department conducts prior to approval of the plan.

927.16 Registered Professional Forester (RPF) Advice [Marin County]

The provisions of 14 CCR 913.8 (b)(5) shall apply when timber operations are conducted in Marin County.

927.17 Decisions on Winter Operations [Marin County]

The Director may prohibit any activity in the winter period that presents an unacceptable risk of significant degradation to the soil and water resources.

928 San Mateo County Rules [San Mateo County]

In addition to forest practice rules applying in the Coast Forest District and Southern subdistrict of the Coast Forest District, rules contained in 928.1 through 928.8 shall apply within the boundaries of San Mateo County. Where the general rules conflict with San Mateo County rules, the San Mateo County rules shall apply.

928.1 Definitions [San Mateo County]

The following definitions shall apply in San Mateo County:

(a) "Haul Route" means all routes to be used for removing forest products from the plan area to the mill or county line.

(b) "Encroachment" means any point at which logging trucks enter onto or exit from a public road, whether the encroachment is newly constructed or not.

CALIFORNIA FOREST PRACTICE RULES

928.2 Contents of Plan [San Mateo County]

In addition to 14 CCR 1034, the following shall apply:

- (a) The estimated number of logging truck loads to be removed and the approximate number of daily trips.
- (b) In addition to 14 CCR 1034(x), the following information shall be clearly provided on the map:
 - (1) The location of scenic roads as designated by the County General Plan or in any other document officially adopted by the county.
 - (2) Location of all structures (including mobile homes or trailers) currently maintained for human habitation within 200 ft. as measured along the surface of the ground from the boundary of the plan area.
 - (3) Location of existing and proposed firebreaks.
- (c) On timber operations requiring submission of a plan, all routes and encroachments onto county roads to be used for removing forest products from the plan area to the mill or county line shall be shown on a road map submitted with the plan. The Director shall consult with the county Transportation Agency before giving approval.

928.3 Flagging [San Mateo County]

(a) In addition to 14 CCR 914.2, the following shall apply in San Mateo County:

Prior to submittal of a plan, the approximate location of proposed constructed tractor roads on slopes over 50% shall be intervisibly flagged on the ground.

(b) In addition to other flagging requirements in Subchapter 3 of Title 14 CCR, the Director, where necessary to protect adjoining properties, shall require flagging of approximate property lines on the site where any truck road, tractor road or harvest area is proposed within 100 ft. of a property line, unless explained and justified in the plan and approved by the Director.

928.4 Performance Bonding [San Mateo County]

When hauling logs pursuant to a THP, the LTO shall provide for the repair of any damage to a county road that is willfully or negligently caused by the LTO's log hauling operations, and shall provide for the repair of any damage caused by the LTO's log hauling operations to appurtenant structures, including, but not limited to, guard rails, signs, traffic signals, culverts, curbs and similar facilities. If necessary to ensure compliance with this section, the county may request, and the Department, upon such request, may require the timber operator or responsible party to post adequate financial security to restore paved or unpaved county roads and appurtenant structures which are damaged by log hauling operations. The request for posting of financial security shall be made to the Department during the THP review procedure and no later than five days before the Director's decision date. The timber operator or responsible party shall post a certificate of deposit, certificate of insurance or performance bond, or other financial security in favor of the Department in a reasonable amount set by the Director, not to exceed \$5,000 per mile of county road used or \$50,000, whichever is less and subject to provisions of Div. 3, Part I, Chapter 1, Article 8, Sec. 11110 through 11113 of the Gov. C. Such cash deposit or other acceptable financial security shall cover a period not to exceed the effective period of the plan.

When a form of financial security is required, logging trucks shall not use the county roads until the required security is posted with the Department. The Director shall release the bond or equivalent to the principal of the security upon completion of log hauling operations and compliance with the requirements of this section. If and when repairs are necessary, the Director shall request the operator to provide for making the repairs. If the repairs are not made the Department may take corrective action and may order the bond, or equivalent, forfeited in an amount not to exceed actual damage. When a bond or equivalent has been posted, the Department shall provide the county with a copy of the Work Completion Report. The county shall advise the Department in writing within 30 days of its receipt of notification of completion of hauling operations or the Work Completion Report if damage has occurred repairs need to be made. If the county fails to notify the Director within 30 days, the bond of surety shall be released.

928.5 Hours of Work [San Mateo County]

Within 300 ft. of any occupied dwelling, the operation of power equipment, including chain saws, except licensed highway vehicles, shall be restricted to the hours between 7:00 a.m. and 7:00 p.m., and shall be

CALIFORNIA FOREST PRACTICE RULES

prohibited on Saturdays, Sundays and nationally designated legal holidays. Where, because of unusual ground conditions or very close proximity of occupied dwellings or special circumstances related thereto, the Director determines that a need exists for further restrictions, he/she may increase the distance and may limit the hours to not less than 8:00 a.m. to 5:00 p.m. An exception to this rule may be granted by the Director where he/she has found that no disturbance will result to the occupants of the dwelling from the use of such equipment.

928.6 Log Hauling [San Mateo County]

(a) Log hauling on public roads is not permitted on Saturdays, Sundays, or on those days which are nationally designated legal holidays.

(b) Log hauling on public roads may be restricted or not permitted by the Director during commute hours or during school busing hours in order to prevent a serious hazard to traffic flow and safety or to prevent hazardous conditions that would endanger public safety.

(c) During log hauling on public roads, the timber operator may be required by the Director to post special traffic signs and/or flagpersons where determined to be necessary to prevent a hazard to traffic.

(d) Where road width will not permit passage of a logging truck and another oncoming vehicle, and adequate turnouts are not present, the Director may require the use of pilot cars equipped with warning signs and flashing lights to guide logging trucks on public roads.

928.7 Cutting Practices [San Mateo County]

(a) Prior to submission of the plan to the Director, all timber proposed for harvest shall be clearly marked with paint at points approximately 4 1/2 feet above the ground and at ground level, except where the Director believes that a sample marking of 20% of the area up to a maximum of five acres would be adequate for plan evaluation.

(b) Where a sample marking has been used, the balance of the timber to be cut, except for hardwoods, shall be marked under the direct supervision of the Forester (RPF) who prepared the plan prior to the time of cutting.

(c) Up to 10% of the trees that are proposed for cutting may be substituted one for one with those proposed to be left uncut provided that the leave tree proportion, size class, distribution and general forest appearance of the residual stand as approved in the preliminary field work is preserved.

Justification for the substitution standard shall be based on unavoidable tree damage, safety factors, lean of trees, location of obstructions or roads or openings insufficient to accommodate felled trees.

[COUNTY RULES, NORTHERN DISTRICT]

945 Lake County Rules [Lake County]

In addition to forest practice rules applying in the Northern Forest District, these rules shall apply within the areas of Lake County designated as Scenic Combining District except as provided by subsection (f) of Public Resources Code section 4516.5. Where the general rules conflict with the Lake County rules, the Lake County rules shall apply.

945.1 Statement of Purpose [Lake County]

The purpose of these rules is to:

(a) insure that the visual and aesthetic sites identified within the Scenic Combining District are adequately identified and protected,

(b) provide direction to RPFs preparing plans which, for the purposes of this section, include THPs, MTHPs, NTMPs, PTEIRs, Notices of Emergency Timber Operations, and any Exemptions Notices pursuant to 14 CCR §§ 1038 and 1104.1,

(c) provide direction to the timber operator conducting timber operations,

(d) provide direction to the Department in its review, approval, and inspection programs.

945.2 Definitions [Lake County]

"Scenic Combining District" means a zone of varying widths adjacent to county and state maintained roadways and certain state and county roads as adopted by county ordinance. The Scenic Combining District

CALIFORNIA FOREST PRACTICE RULES

is administered by the Community Development Department of Lake County.

Scenic Combining District width is measured from the edge of the roadway and may extend on both sides of the road. The width of the Scenic Combining District is identified, mapped, and administered by the Community Development Department.

945.3 Timber Harvest Prescriptions [Lake County]

The following rules shall be applied to all areas designated Scenic Combining District. Limited timber harvesting may be allowed within the Scenic Combining Districts using the following criteria:

(a) Selection. In the areas designated as Scenic Combining Districts, only the selection regeneration method and commercial thinning shall be used. The group selection method (14 CCR § 933.2(a)(2)(B)) shall not be used.

(1) A map that clearly defines the location and extent of the Scenic Combining District occurring on the site to be harvested shall be submitted with the Plan.

(2) Trees to be harvested shall be marked by or under the supervision of an RPF. All trees to be harvested shall be marked within the Scenic Combining District prior to a preharvest inspection for evaluation.

(3) In all areas designated as Scenic Combining Districts, at least 75 square feet per acre of conifer basal area shall be retained.

(4) Post harvest stand stocking levels of conifers shall be stated in the Plan. The level of residual stocking shall be consistent with maximum sustained production for high quality timber products. In no case shall conifer stocking levels per acre be reduced below the following standards:

(A) Within the first 150 feet of the Scenic Combining District, at least 50% of the trees 18 to 24 inches dbh, and 50% of the trees 26 inches dbh and larger, shall be retained.

(B) Between 150 and 300 feet of the Scenic Combining District, at least 50% of the trees less than 18 inches dbh, 40% of the trees 18 - 24 inches dbh, and 33% of the trees 26 inches dbh and larger shall be retained.

(C) Between 300 feet and the outermost boundary of the Scenic Combining District, 75 square feet of basal area per acre shall be retained.

(b) Logging roads, tractor roads, and landings shall be screened from direct view to the extent feasible by leaving trees and vegetation between the disturbed areas and vista points that would attract viewers.

(c) Hardwoods shall be considered for the purposes of aesthetic enhancement and a minimum of 25% of the pre-harvest hardwood basal area shall be retained.

(d) A second harvest shall not be conducted sooner than ten years following completion of an initial harvest unless an emergency condition exists pursuant to 14 CCR § 1052 *et seq.* in the interim, or pursuant to a conversion exemption (14 CCR § 1104.1).

945.4 Hours of Operation [Lake County]

Within 300 feet of any occupied dwelling, the operation of power equipment, including chain saws, except licensed highway vehicles, shall be restricted to the hours between 7:00 a.m. and 7:00 p.m. and shall be prohibited on Saturdays, Sundays and nationally designated holidays. The Director may grant an exception to this rule where the Director has found that no disturbance will result to the occupants of the dwelling from the use of such equipment.

945.5 Exempt and Emergency Notice Operations [Lake County]

Timber operations may be conducted within the Scenic Combining District in compliance with an Exemption pursuant to 14 CCR § 1038, an Exemption pursuant to 14 CCR § 1104.1, or an Emergency Notice pursuant to 14 CCR § 1052. Such operations, when feasible, shall be conducted in a manner consistent with the limitations described in 14 CCR §§ 945.3(a), subsections (1), (2), and (3); 945.3(b); 945.3(c); and 945.4.

CALIFORNIA FOREST PRACTICE RULES

COUNTY RULES, SOUTHERN DISTRICT

965 Monterey County Rules [Monterey County]

In addition to forest practice rules applying in the Southern Forest District, rules contained in Sections 965.1 through 965.10 shall apply within the boundaries of Monterey County. Where the Southern Forest District rules conflict with Monterey County rules, the Monterey County rules will apply.

965.1 Haul Routes [Monterey County]

On timber operations requiring a plan all haul routes for removing forest products shall be shown on a road map and shall include routes from the harvest site to the mill or county line. Such map shall be submitted with the plan. A proposed change in the use of public roads that are part of the haul route shall be presumed to be a substantial deviation unless the plan submitter requests that the proposed change be considered a minor deviation in accordance with the procedures set forth in 14 CCR 1036 and 1040 and the Director so determines. The Director shall consult with the County Planning Department and Public Works Department before giving approval.

965.2 Hauling to the Nearest Public Road [Monterey County]

Those portions of offsite haul roads to be used in the conduct of the timber operation, from the area where timber harvesting is to occur to the nearest public road, shall be shown on the plan. In addition to the requirements to furnish a list of certain property owners pursuant to 14 CCR 1032.7 (e), the plan submitter shall furnish to the Department at the time of submission of the plan the names and addresses of property owners with property fronting or bordering that portion of the haul route lying between the plan area and the nearest public road. The Department shall give notice of public hearing if requested by the county to each of these owners and those individuals specified in 14 CCR 1037.1(b) and 1037.3.

965.3 Public Road Protection [Monterey County]

The construction of logging roads, tractor roads, or landings within 100 feet of the edge of the traveled surface of a public road is prohibited except where:

- (a) Logging roads are needed for access to the area to be harvested.
- (b) It is explained and justified in the plan where construction of these facilities in this area will result in better protection of scenic values or provide better erosion control in the conduct of the timber operation.

965.4 Log Hauling [Monterey County]

- (a) Log hauling on public roads is not permitted on Saturdays, Sundays, or on those days which are nationally designated legal holidays.
- (b) Log hauling on public roads may be restricted or not permitted by the Director during specified hours to prevent hazardous traffic conditions.

965.5 Winter Period [Monterey County]

The winter period for Monterey County shall be October 15 through April 15.

965.6 Big Sur Coast [Monterey County]

The following rules shall apply to all THPs within the area covered by the Big Sur Coast Land Use Plan of September 13th, 1984 (Big Sur LUP).

- (a) West of Highway 1 or within the critical viewshed of Highway 1 as defined in the Big Sur LUP only the sanitation-salvage silvicultural method will be permitted.
- (b) Timber operations outside the critical viewshed of Highway 1 shall be screened from direct public view to the extent feasible by leaving trees and other vegetation between disturbed areas and public roads.
- (c) New road construction is not permitted within the critical viewshed of Highway 1 unless a field review of the proposed road reveals no significant degradation of the critical viewshed. New road construction outside the critical viewshed shall be located to minimize the removal of native trees and shall not be allowed across slopes over 30% unless no feasible alternative exists for the proposed location, or the road better achieves the overall resource protection objectives.

CALIFORNIA FOREST PRACTICE RULES

(d) All excess material resulting from new road construction shall be end hauled and deposited in an area where visual impact will be minimized. Sidecasting of excess material is prohibited.

(e) Within environmentally sensitive plant and wildlife habitats as described in the Big Sur LUP the Director shall require a field review by a qualified wildlife biologist prior to approval of the THP. If the field review identifies significant adverse effects to the habitat, the Director shall deny the THP unless measures sufficient to mitigate the adverse effects are included in the THP.

(f) Within those drainages identified in the Big Sur LUP and designated by Monterey County as watershed resource study areas, the Director shall require a field review by a qualified hydrologist or erosion control specialist prior to approval of the THP. If the field review identifies significant adverse effects to the cumulative water demands of the watershed, the Director shall deny the THP unless measures sufficient to mitigate the adverse effects on water supply are included in the THP.

(g) In addition to the requirements of 14 CCR 956 through 956.7, the minimum watercourse and lake protection zone shall be 150 ft. on Class I and II waters unless a smaller zone can be explained and justified in the THP.

965.7 Public Water Agency Representative [Monterey County]

In the case of any timber operation proposed to be carried out in an area which serves as a watershed for any publicly owned water purveyor, the Director shall request a representative of such water purveyor to assist the Department as an advisor in the review process, pursuant to the provision of 14 CCR 1037.5; such water purveyor representative shall be permitted to participate in all review team meetings.

965.8 Performance Bonding [Monterey County]

When hauling logs pursuant to a THP, the LTO shall provide for the repair of any damage to a county road that is willfully or negligently caused by the LTO's log hauling operations, and shall provide for the repair of any damage caused by the LTO's log hauling operations to appurtenant structures, including, but not limited to, guard rails, signs, traffic signals, culverts, curbs and similar facilities. If necessary to ensure compliance with this section, the county may request, and the Department, upon such request, may require the timber operator or responsible party to post adequate financial security to restore paved or unpaved county roads and appurtenant structures which are damaged by log hauling operations. The request for posting of financial security shall be made to the Department during the THP review procedure and no later than five days before the Director's decision date. The timber operator or responsible party shall post a certificate of deposit, certificate of insurance or performance bond, or other financial security in favor of the Department in a reasonable amount set by the Director, not to exceed \$5,000 per mile of county road used or \$50,000, whichever is less and subject to provisions of Div. 3, Part I, Chapter 1, Article 8, Sec. 11110 through 11113 of the Gov. C. Such cash deposit or other acceptable financial security shall cover a period not to exceed the effective period of the plan.

When a form of financial security is required, logging trucks shall not use the county roads until the required security is posted with the Department. The Director shall release the bond or equivalent to the principal of the security upon completion of log hauling operations and compliance with the requirements of this section. If and when repairs are necessary, the Director shall request the operator to provide for making the repairs. If the repairs are not made the Department may take corrective action and may order the bond, or equivalent, forfeited in an amount not to exceed actual damage. When a bond or equivalent has been posted, the Department shall provide the county with a copy of the Work Completion Report. The county shall advise the Department in writing within 30 days of its receipt of notification of completion of hauling operations or the Work Completion Report if damage has occurred repairs need to be made. If the county fails to notify the Director within 30 days, the bond of surety shall be released.

965.9 Erosion Control Maintenance [Monterey County]

The plan submitter shall maintain all drainage structures and drainage facilities required by these rules in effective working condition throughout one winter period after completion of timber operations. A work completion report may not be filed until this requirement has been met.

CALIFORNIA FOREST PRACTICE RULES

965.10 THP Description [Monterey County]

In addition to the requirements of 14 CCR 1034(g), the THP description shall include the assessor's parcel numbers of all parcels on which timber operations will be conducted.

Article 14 Archaeological and Historical Resource Protection [Article 12. Northern]

929, 949, 969 Statement of Purpose [All Districts]

The purpose of this article is to:

- (a) ensure that the significant archaeological and historical sites within the site survey area are adequately identified and protected,
- (b) to provide direction to RPFs preparing THPs (which includes all forms of THPs including, but not limited to, Modified THPs and Nonindustrial Timber Management Plans (NTMPs), Program Timber Harvesting Plans (PTHPs), Notice of Emergency Timber Operations (Emergency Notices), and any Exemption Notices pursuant to 14 CCR Sections 1038 and 1104.1,
- (c) provide direction to the timber operator conducting timber operations,
- (d) provide direction to the Department in its review, approval and inspection programs.

929.1, 949.1, 969.1 Plan, and Emergency Notice Preparation [All Districts]

(a) Preparing a THP.

Prior to submitting a THP, the RPF, or the RPF's supervised designee:

- (1) Shall conduct an archaeological records check using a form entitled "Archaeological Records Check Request for a CDF Project" dated 1/1/97. The RPF may use a previously-conducted archaeological records check for the property to satisfy this requirement if it covers the entire area proposed for timber operations and if it meets the definition of "current archaeological records check" in 14CCR 895.1.
- (2) Shall provide written notification to Native Americans of the location of the THP. The RPF shall allow a minimum of 10 days for notification and response prior to submitting the THP to the Director. The remainder of the 10-day waiting period is waived when all Native Americans required to be noticed respond in less than 10 days. This notification shall:
 - (A) Request information concerning the existence of any archaeological or historical sites within the THP boundaries which may be known by Native Americans.
 - (B) Provide the location of the plan area by county, section, township, and range, and the approximate direction and distance from the nearest community or well-known landmark.
 - (C) Provide the estimated earliest date that the Director may approve the plan.
 - (D) Include a statement that the Native American groups may participate in the plan review process and provide the address and phone number of the appropriate CDF office to contact.
 - (E) Include a statement that a Confidential Archaeological Addendum will be prepared for the project and a copy of pertinent information contained within it may, at the discretion of the Director, be obtained from the Director.
 - (F) Provide a map which displays the approximate boundary of the THP area, a map legend, and a scale.
 - (G) Provide the name of the USGS 7.5' minute quadrangle map(s) upon which the project is located.

(3) Shall provide a professional archaeologist or a person with archaeological training (in accordance with 14CCR Section 929.4, 949.4, 969.4) to conduct a field survey for archaeological and historical sites within the site survey area. Previous archaeological surveys within the site survey area may also be used to partially or entirely satisfy this requirement.

(b) Submitting a Confidential Archaeological Addendum for a THP.

The RPF shall include the following information in a Confidential Archaeological Addendum with the proposed THP:

- (1) Administrative Information which is not confidential and may be released to the public. This includes:
 - (A) The name, affiliation, address, and phone number of the archaeological surveyor.
 - (B) The name, affiliation, address, and phone number of the RPF, if different than the archaeological surveyor.

CALIFORNIA FOREST PRACTICE RULES

- (C) The plan name ascribed by the RPF, plan number (if known), type, and approximate acreage.
 - (D) The county, legal description, and name of USGS 7.5' Quad(s) within which the project is located.
 - (E) The date the CAA was completed.
 - (F) The name of the author of the CAA.
 - (G) The signature of the archaeological surveyor.
- (2) Archaeological Records Check Information. A copy of the completed request form and written reply (including mapped information) from the Information Center shall be attached, or a justification as to why that is not possible shall be included.
- (A) If the completed request form and written reply from the Information Center are attached, no additional information is required.
 - (B) If the completed request form and written reply from the Information Center are not attached, the following information shall be included:
 - (1) Justification why completed request form and written reply could not be attached.
 - (2) The date the records check was conducted at the Information Center.
 - (3) The Information Center File Number.
 - (4) Summary of records check results discussing whether or not archaeological or historical sites are known or suspected to exist within the site survey area and whether or not the site survey area has a previous archaeological investigation on record.
 - (3) Results of consultation with Native Americans pursuant to 14CCR Section 929.1 [949.1, 969.1](a)(2). This shall include:
 - (A) An example of a notification letter and project map submitted to Native American contacts.
 - (B) Copies of any written responses received from Native American contacts.
 - (C) A list of the individuals or groups which were provided written notification.
 - (D) Date the notification was sent.
 - (E) Results of notification.
 - (4) A list of the research done prior to field survey including literature reviewed and persons contacted in addition to the required archaeological records check with Information Center and Native Americans, and a summary of the results of this research.
 - (5) Information on the current or previous archaeological surveyor(s), which is not confidential. This shall include:
 - (A) the name of the current archaeological surveyors and an indication of whether or not the person either meets the specifications of a professional archaeologist as defined in 14 CCR Section 895.1 or, meets the requirements specified in 14CCR Section 929.4 [949.4, 969.4].
 - (B) the name of any previous archaeological surveyors, if known.
 - (6) Description of archaeological survey methods and procedures including survey strategy, time spent conducting archaeological field survey, survey coverage intensity, and ground visibility or other limitations.
 - (7) A list and description of all archaeological or historical sites identified within the site survey area including information on the site(s) size, type, and condition. The designations used in this listing of sites found shall be consistently used throughout the CAA.
 - (8) An Archaeological Coverage Map or maps prepared in accordance with the specifications identified in the definition of an Archaeological Coverage Map in 14 CCR Section 895.1.
 - (9) A preliminary determination of significance of identified archaeological and historical sites, if damaging effects from timber operations cannot be avoided. This determination shall be based upon the criteria for a significant archaeological or historical site listed in 14CCR Section 895.1.
 - (10) Description of any specific enforceable protection measures to be implemented both within the site boundaries and within 100 feet of the site boundaries.
 - (11) Information concerning the proposed on-site meeting between the RPF or supervised designee familiar with on-site conditions and the LTO to discuss protection of archaeological and historical resources, if required, pursuant to 14 CCR Section 929.2 [949.2,969.2](b).

CALIFORNIA FOREST PRACTICE RULES

(12) Information concerning site recording requirements pursuant to 14 CCR Section 929.1 [949.1,969.1](c)and(f).

(13) Other applicable information, if any, concerning the archaeological survey for this project.

(14) List of attachments to the CAA.

(c) Site Records. Any time prior to THP approval, the RPF or the RPF's supervised designee shall submit completed site records for each site determined to be a significant archaeological or historical site in a manner consistent with the recording standards identified in the State Office of Historic Preservation's "Instructions For Recording Historical Resources" March, 1995, which is incorporated by reference.

(d) Emergency Notice of 3 Acres Or More.

(1) Prior to submitting an Emergency Notice of three acres or more, the RPF:

(A) Shall ensure that an archaeological field survey is, or has been previously conducted by a professional archaeologist or person with archaeological training (pursuant to 14CCR Section 929.4 [949.4, 969.4]) within the site survey area.

(2) Prior to submitting an Emergency Notice of three acres or more, the RPF or the RPF's supervised designee:

(A) Shall complete a current archaeological records check. This check may be conducted by telephone. If the Information Center is unable to provide the information within three business days following receipt of an RPF's request for an Emergency Notice records check, the records check requirement is waived.

(B) Shall submit a Confidential Archaeological Letter that includes the information required by 929.1 [949.1,969.1](b)(2),(6),(7),(8), and (10), including site records, if required pursuant to 929.1 [949.1, 969.1](f).

(C) Shall send a copy of the Emergency Notice to Native Americans.

(e) Emergency Notice of Less Than 3 Acres.

(1) Prior to submitting an Emergency Notice of less than three acres, the RPF or the RPF's supervised designee shall:

(A) Conduct an archaeological survey for said area to determine whether it contains any significant archaeological sites using the criteria for a significant archaeological or historical site defined in 895.1.

(B) Send a copy of the Notice to Native Americans.

(2) An archaeological records check, Confidential Archaeological Addendum, or Confidential Archaeological Letter, is not required.

(3) No timber operations shall occur within the boundaries of any significant archaeological or historical sites as determined by the RPF or the RPF's supervised designee.

(f) Submitting Archaeological and Historical Information to Information Centers.

Within 30 days following the Director's approval of a THP or acceptance of an Emergency Notice of three acres or larger, the RPF or supervised designee shall send to the appropriate Information Center of the California Historical Resource Information System:

(1) a complete Confidential Archaeological Addendum which includes all changes and additions required in the THP review process and which identifies the plan number, or, for Emergency Notices of three acres or larger, a Confidential Archaeological Letter.

(2) two copies each of any completed archaeological or historical site records for:

(A) archaeological sites determined to be significant, or

(B) sites that a person elects to record, but for which no determination of significance has been made.

The records shall be completed by a person who satisfies the requirements specified in 14CCR 929.4 [949.4,969.4] in a manner consistent with the recording standards identified in the State Office of Historic Preservation's "Instructions For Recording Historical Resources" March, 1995, which is incorporated by reference.

(3) The RPF or supervised designee shall ensure that the site records are completed in the manner specified in subsection (2).

CALIFORNIA FOREST PRACTICE RULES

929.2, 949.2, 969.2 Protection Measures for THPs and Emergency Notices 3 Acres and Larger [All Districts]

(a) (1) The RPF shall describe in the separate Confidential Archaeological Addendum or Letter, measures to be taken to mitigate or avoid substantial adverse change to any known significant archaeological or historical sites.

(2) The RPF may propose, and the Director may agree to, site specific protection measures for any identified archaeological or historical site without evaluating the significance of the site. These proposed protection measures shall be designed to ensure protection of such archaeological and historical sites from damaging effects. Avoidance of activities which will cause damaging effects is a preferred protection measure.

(b) The RPF or supervised designee familiar with on-site conditions shall meet with the LTO prior to the start of timber operations at each archaeological or historical site that is described in the plan or notice that requires avoidance or other protection measures and do the following:

(1) show the LTO the location, extent and boundaries of each archaeological or historical site requiring protection,

(2) discuss with the LTO the protection measures,

(3) apprise the LTO of the confidentiality requirements for any information concerning the physical location of archaeological or historical sites.

(c) If the RPF or supervised designee is unable to perform the duties in 929.2 [949.2, 969.2](b), the RPF shall:

(1) explain the reasons in the emergency notice, plan, or as a minor amendment to the plan,

(2) (A) meet with the plan submitter, timberland owner, or their authorized agent, and review in the field, the items described in 929.2 [949.2, 969.2](b),

(B) if the plan submitter, timberland owner, or their authorized agent will not comply with the RPF's or RPF's supervised designee's request for a meeting, the RPF shall notify the Director.

(3) except for an emergency notice, notify the plan submitter in writing that it is the plan submitter's responsibility to transfer the information in 929.2 [949.2, 969.2](b) to the LTO per 1035(g),

(4) notify the Director in writing.

929.3, 949.3, 969.3 Post Review Site Discovery [All Districts]

If a person discovers a potentially significant archaeological or historical site after a THP, Emergency Notice, or Exemption is accepted by the Director, the following procedures apply:

(a) The person who made the discovery shall immediately notify the Director, LTO, RPF, or timberland owner of record.

(b) The person first notified in (a) shall immediately notify the remaining parties in (a).

(c) No timber operations shall occur within 100 feet of the identified boundaries of the new site until the plan submitter proposes, and the Director agrees to, protection measures pursuant to 14CCR 929.2 (949.2, 969.2).

(d) A minor deviation shall be filed to the THP if the plan is changed.

(e) The Director shall provide the proposed minor deviation or portions of the minor deviation, to Native Americans and the NAHC when archaeological sites are involved.

929.4, 949.4, 969.4 Archaeological Training Requirements [All Districts]

To meet the requirement of 14CCR 929.1 [949.1, 969.1] archaeological surveys of Timber Harvesting Plan, or Emergency Notice areas for archaeological or historical sites shall be conducted only by a professional archaeologist or a person who has attended a training program approved by the Director within five years prior to submission of the THP, or Emergency Notice. The training program must meet the following standards:

(a) The course shall use education materials approved by the Director which address the current regulations and procedures for the identification, recordation, and protection of archaeological and historical resources during timber operations.

(b) The course may require that the applicant demonstrate, in the field, and in a final written examination, the ability to conduct a record search, perform field identification, complete an archaeological site record, and to identify appropriate mitigation and protection measures for archaeological or historical sites covered

CALIFORNIA FOREST PRACTICE RULES

in the course.

(c) The Director shall issue a certificate of training to all students that satisfactorily complete the training course.

(d) Following an individual's successful completion of an archaeological training course approved by the Director, he or she may enroll in a refresher training course, approved by the Director, to renew a 5-year archaeological training certification.

(e) The Director may conduct the archaeological training courses (in addition to or in-lieu of approving programs conducted by others) at least annually.

929.5, 949.5, 969.5 Site Recording [All Districts]

The Director shall ensure that all archaeological or historical sites determined to be significant and located within the site survey area on THPs, or Emergency Notices are recorded in a manner consistent with the recording standards identified in the State Office of Historic Preservation's "Instructions For Recording Historical Resources" March, 1995, which is incorporated by reference.

929.6, 949.6, 969.6 Protection of Sites During Timber Operations [All Districts]

No person, except as otherwise permitted by law, who is involved in timber operations shall excavate, collect artifacts from, vandalize or loot archaeological or historical sites located within the THP, Emergency Notice or Exemption boundary.

929.7, 949.7, 969.7 Determination of Significance [All Districts]

(a) A determination of significance shall be made for an identified archaeological or historical site within the site survey area on a THP, or Emergency Notice by a person who satisfies the requirements specified in 14 CCR 929.4 [949.4, 969.4] if damaging effects from timber operations cannot be avoided.

(b) The determination of significance shall:

(1) Be based upon criteria defined for significant archaeological or historical sites in 14 CCR 895.1

(2) Utilize any information provided by Native Americans, archaeological, historical or ethnographic data pertinent to the region and to the cultural resource, and the physical characteristics of the archaeological or historical site.

(c) If required by subsection (a), a preliminary determination of significance shall be made by the RPF or the RPF's supervised designee and provided in the Confidential Archaeological Addendum.

(d) Where the Director determines that timber operations may cause a substantial adverse change to a significant archaeological or historical site and the RPF and the Director cannot agree upon protection measures, a professional archaeologist provided by the THP submitter shall make a survey and prepare a report on the potentially affected site or sites and the potential impacts of the proposed timber operations. The part of the report that relates to archaeological sites is confidential. This report, if it discusses impacts on Native American archaeological sites, shall be provided by the Director to Native Americans and the NAHC. This report shall contain recommendations for mitigation, the elimination of impacts, or for the reduction of impacts to avoid or prevent substantial adverse change to significant archaeological or historical resources. The report shall meet the standards of the Preservation Planning Bulletin, Number 4, December 1989 (Office of Historic Preservation), entitled Archaeological Resource Management Reports (ARMR): Recommended Contents and Format.

The Director shall make the final determination of significance and substantial adverse change based on advice of a professional archaeologist.

SUBCHAPTER 7 ADMINISTRATION

Article 1 Timber Operator Licenses

1020 Board Authority Delegated

The Board of Forestry [*and Fire Protection*] delegates its authority under Article 6 (commencing with Section 4571) of Chapter 8, Part 2, Division 4 of the PRC, to the Director.

CALIFORNIA FOREST PRACTICE RULES

1022 License

The license defined in PRC 4524, is designated as either "Timber Operator License" or "Limited Timber Operator License."

1022.1 Limited Timber Operator License

The Director may issue a license for commercial cutting and/or removal of minor forest products as here listed: Christmas trees, tanbark, fuelwood, root crown burls, posts and split products, but excluding poles, piling, sawlogs, veneer logs and pulp logs. Said license is designated as "Limited Timber Operator License."

1022.2 License for Site Preparation

A timber operator's license is required for mechanical site preparation activities undertaken before the stocking standards of the Act and rules have been met in a logging area. Site preparation activities involving broadcast burning are exempt from timber operator licensing requirements.

1022.3 License for Erosion Control Maintenance

A timber operator license is not required for the maintenance of erosion control structures following the completion of timber operations described in an approved work completion report for a THP.

1023 Issuance of License

Upon receipt of a proper written application and payment of the prescribed license fee, the Director may issue either a Timber Operator License or a Limited Timber Operator License.

1023.1 Company, Corporation and Partnership Licenses

Each subsidiary of companies or corporations, and each division thereof that is a separate unit and separately managed, which conducts timber operations shall be individually licensed. Partnership consisting of individual licensees and operating as a copartnership must obtain a license as a partnership. A license is not transferable.

1024 Application Form and Content

Application for a license, or renewal of license, in a form prescribed by the Director, shall contain, and is not limited to, the following information:

- (a) Specific type of license requested.
- (b) Name in which License is to be issued.
- (c) Name, mailing address and street address of applicant.
- (d) Satisfactory proof of identity.
- (e) Name and address of principal officer in California for service of documents.
- (f) Name, mailing address and telephone number of the Insurance Agent providing the Insurance Certificate when such certificate is required by PRC 4572.
- (g) If a corporation, name of state of incorporation, address of home office, address of California office, name and address of resident agent in California for service, and the name and address of the individual who will attend the timber operator education program for the corporation, if required.
- (h) If not a California corporation, or if an individual, firm, or partnership that has no office in California, name and address of a natural person that applicant designates as resident agent in California for service.
- (i) The application must contain a consent for the Director, and agents and employees thereof, to inspect timber operations of the applicant.
- (j) Timber Operator License Application shall have a Certificate of Completion from a timber operator education program approved by the Director attached to the application unless, the applicant has held a prior license.
- (k) An application for a limited timber operators license shall have either a Certificate of Completion from an approved timber operator education program or a completed questionnaire attached to the application, unless the applicant has held a prior license. The questionnaire shall be administered to the applicant by the Director either orally or in writing. The questionnaire shall be prepared or approved by the Director and shall pertain to the content of the regulations of the Board (Title 14, CCR Division 1.5).

CALIFORNIA FOREST PRACTICE RULES

1024.1 Timber Operator Education

The Director shall only approve timber operator education programs which meet the following standards:

(a) The course shall use education materials approved by the Director. The Director shall only approve materials which address the contents of the rules of the Board.

(b) Certificate of Completion shall be given when an applicant successfully completes the timber operator education program. An applicant shall have successfully completed the timber operator education program if he/she has attended the entire program and has completed all training materials. The Director may conduct the timber operator education programs in addition to or in-lieu of approving programs conducted by others.

1024.2 Qualifying Experience

"Work experience", within the meaning of Public Resources Code section 4572(b)(2)(A), shall include, but not be limited to, such timber operations activities as felling, bucking and limbing of logs, cable rigging, choker setting, heavy equipment operation, yarding, loading and hauling of logs, logging road building and waterbreak installation, or on site assistance with any of these activities. General construction and reforestation work such as brush removal and tree planting are not qualifying experience. Direct supervision of timber operations shall meet the requirement for having experience in "two or more areas [activities] of employment".

1024.3 Application Processing

(a) The applicant shall be informed by the Department, in writing and postmarked, within 15 working days of receipt of the application, whether such application is complete and accepted for filing, or is deficient and what specific information is required.

(b) The applicant shall be informed of the Department's decision on licensure, in writing and postmarked, within 15 working days of filing a complete application.

(c) The actual minimum, median and maximum processing times for an application from the time of receipt of the application until the Department makes a final decision on the application are:

- (1) Minimum: 1 hour;
- (2) Median: 5 days;
- (3) Maximum: 168 days.

1024.4 Returned Checks

Any fee payment document which is returned unpaid for any reason from the institution upon which the document is drawn, shall render the application incomplete, and any license issued pursuant to that fee payment document shall be invalid at the end of 10 working days following written notice to the applicant. If payment by cash, cashier's check, or money order is received within the 10 day period, such license shall continue without interruption. If payment is not received within the 10 working day period, the license shall remain invalid and a new license shall be required.

1024.5 Insurance Maintenance

Licensees shall maintain in force an insurance policy, if required, as defined in subsection (c) of [PRC] Section 4572. Failure or refusal to do so shall render the application incomplete, and a license shall be invalid. If an Insurance Certificate showing insurance coverage is received by the Department demonstrating no lapse in insurance coverage, the license shall continue without interruption. If no such Insurance Certificate is received, the license shall remain invalid and a new license shall be required.

1025 Fees for Licenses

The following license fees shall prevail:

- (a) "Timber Operator License"
- | | |
|-----------------|---------|
| New License | \$75.00 |
| Renewal License | \$50.00 |

CALIFORNIA FOREST PRACTICE RULES

(b) "Limited Timber Operator License"

New License	\$35.00
Renewal License	\$25.00

1026 License Renewal

Licenses are good only for the calendar year(s) issued.

(a) New licenses. For a new license, a person shall submit the appropriate and complete application, insurance certificate, if needed, and fees. A new license shall be valid from the date of issuance to January 1st of odd-numbered years for odd-numbered licenses and January 1st of even-numbered years for even-numbered licenses. The fee for a newly issued license shall be based on a proration of the annual rate as provided in section 1025.

(b) Renewals. A completed application for renewal shall be submitted to the Director on alternating years with odd-numbered licenses expiring on January 1st of odd-numbered years and even-numbered licenses expiring on January 1st of even-numbered years. All licenses for which renewal applications, with the required fee, are not received by the Director, or postmarked, on or before December 1st shall expire on January 1st and a new license shall be required.

1027 License Denial

An application for a license or an application for renewal of a license may be denied by the Director upon a statement of issues in accordance with the procedures set forth in Chapter 5 (commencing with Section 11500) of Part 1, Division 3, Title 2 of the Government Code.

1027.1 Basis of Denial

The Director may deny issuance of any license either upon original application or upon application for renewal for any of the reasons set forth in PRC 4573. In addition, the Director may deny any application for renewal until any violations of the rules and regulations of the Board and provisions of the Forest Practice Act by the applicant as exist on the date of submission of the renewal application, of which the applicant has been notified and given reasonable opportunity to correct, are corrected on such reasonable terms and conditions as the Director may require, including planting of reasonable numbers of seedlings and young growth trees to restock cutover lands.

1027.2 Partnership and Corporation Denials

Licenses and renewals may be denied partnerships where one of the partners had uncorrected violations within 3 years of the application. If a corporation is owned or controlled by a person denied a license or a renewal, the corporation may be denied a license or a renewal pending satisfactory correction of the deficiencies and adherence to the Forest Practice Act and rules, or removal of said person.

1027.3 Multiple licenses

Only one (1) license may be issued to any partnership, corporation, or individual business entity.

1029 License Availability.

The license, or copy of it, shall be available for inspection at the site of active timber operations.

1030 Licensee: Change of Address

a. The licensee shall:

- 1.** Maintain a California mailing address to which official written communications from the Director shall be sent and received.
- 2.** Provide such address on licensee's application.
- 3.** Notify the Director at the Sacramento office in writing within 15 days of any change of address.

b. The Director shall maintain all names and mailing addresses in a registry to be used for service of documents pursuant to section 11505 of the Government Code.

CALIFORNIA FOREST PRACTICE RULES

Article 2 Timber Harvesting Plan

1032 Timber Harvesting Plan Filing Locations

The Timber Harvesting Plan for proposed timber operations required by Article 7, Chapter 8, Part 2, Division 4 of the PRC (commencing with Sec. 4581) shall be submitted in writing with the Director on a form that meets these regulations at the following Department offices as appropriate:

Office Location	For Timber Operations in:
<i>[Region] Chief</i> <i>[Coast-Cascade Region]</i> California Department of Forestry and Fire Protection 135 Ridgway Ave Santa Rosa, CA 95401	Alameda, Colusa, Contra Costa, Del Norte, Humboldt, Lake, Marin Mendocino, Napa, San Mateo, <i>[San Francisco]</i> , Santa Clara Santa Cruz, Solano, Sonoma, Yolo, and western Trinity counties.
<i>[Cascade Area] Chief</i> <i>[Cascade Area]</i> California Department of Forestry and Fire Protection <i>[6105 Airport Road]</i> Redding, CA 96002	Butte, Glenn, Lassen, Modoc, Nevada, Placer, Plumas, Shasta, Sierra, Siskiyou, Sutter, Tehama, Yuba, and eastern Trinity counties
<i>[Region] Chief</i> <i>[Sierra-South] Region</i> California Department of Forestry and Fire Protection 1234 East Shaw Avenue Fresno, CA 93710	Alpine, Amador, Calaveras, El Dorado, Fresno, Kern, <i>[Kings,]</i> Madera, Mariposa, Merced, Monterey, <i>[Sacramento, San Joaquin]</i> San Benito, Stanislaus, Tuolumne, and Tulare counties.
<i>[South Area] Chief</i> <i>[South Area]</i> California Department of Forestry and Fire Protection 2524 Mulberry Street, Riverside, CA 92501	Imperial, Inyo, Los Angeles, Mono, Orange, Riverside, San Bernardino, San Diego, San Luis Obispo, Santa Barbara and Ventura counties

1032.7 Plan Submittal and Notice of Intent

(a) A plan shall be submitted by the person who owns, leases, contracts, or operates on timberland to harvest timber for commercial purposes.

(b) Where the land or timber is owned or operated by parties other than the person executing the plan the person submitting the plan shall give prompt written notice of such plan to those parties.

(c) The RPF preparing the plan shall submit to the Director, with the plan, a Notice of Intent to Harvest Timber (Notice of Intent): (1) if any proposed boundary lies within 300 feet of any property not owned by the timberland owner, or (2) any plan amendment that changes a plan boundary so that the new boundary lies within 300 ft. of property not owned by the timberland owner, or (3) with any plan amendment that changes the silvicultural method if a Notice of Intent was required for the plan by condition (1) or (2) above.

(d) A Notice of Intent shall include the following information:

(1) The names of the timberland owner, the RPF who prepared the Plan, and the Plan Submitter.

(2) The location of the plan area by county, section, township, and range, and the approximate direction and distance to the plan area from the nearest community or well-known landmark.

(3) The name of and distance from the nearest perennial stream and major watercourse flowing through or downstream from the Plan area.

CALIFORNIA FOREST PRACTICE RULES

- (4) The acres proposed to be harvested.
 - (5) The regeneration methods and intermediate treatments to be used.
 - (6) The estimated earliest date that the Director may approve the plan. This is 15 days from receipt of the Plan by the Department, except in counties for which rules and regulations have been adopted pursuant to Sec. 4516.5 and 4516.8 of the PRC where the earliest date the Director may approve the Plan is 45 days after the receipt of the plan by the Department.
 - (7) A statement that the public may review the plan at the appropriate Regional Office of CDF and that a copy of the plan may be obtained from the Department upon payment of the applicable charge.
 - (8) A map which provides the approximate boundary of the THP area, a map legend, and a scale. This map shall be posted with the Notice of Intent.
 - (9) A statement that questions or concerns regarding the specific THP should be directed to the applicable CDF Regional Office for public input incorporation into an Official Response Document.
 - (10) A statement of whether there is a known overhead electric power line on the proposed plan area except lines from transformers to service panels.
- (e) The RPF preparing the plan shall furnish to the Department at the time of submission of the plan, the names and mailing addresses of all property owners within 300 ft. of the plan boundary. Either a list compiled from the latest equalized assessment roll or a list provided by a title company doing business in California compiled within 60 days of submission of the plan shall be deemed sufficient for compliance with the subsection.
 - (f) The Department shall mail copies of the Notice of Intent within two working days of receipt of the plan to all persons identified in (e) above.
 - (g) Prior to plan submission, the person submitting the Plan shall post a copy of the Notice of Intent including a map as described in (d)(8) at a conspicuous location on the public road nearest the Plan site. Said Notice of Intent shall be on colored paper or identified with colored flagging so as to be easily visible to the public.

1032.8 Notice of Intent-Distribution by Director

The Director shall distribute copies of each Notice of Intent within two working days of receipt to:

- (a) The office of the County Clerk of the county in which operations are proposed for posting at the customary place for posting environmental affairs.
- (b) The local Ranger Unit headquarters for posting.
- (c) At such other locations as the Director may deem desirable and feasible to provide adequate public notice.

1032.9 Request for Notification of Timber Harvesting Plan Submission

- (a) Each Regional Office of the Department shall maintain a list of timber harvesting plans submitted each day.
- (b) When any person requests notice of submissions of timber harvesting plans, the Director shall provide the person, free of charge, with a copy of the list of timber harvesting plans submitted on the date or dates requested. If no specific date is requested, a copy of the lists for the preceding week shall be provided.

1032.10 Request for Information on Domestic Water Supplies

The THP submitter shall provide notice by letter to all other landowners within 1,000 feet downstream of the THP boundary whose ownership adjoins or includes a Class I, II, or IV watercourse(s) which receives surface drainage from the proposed timber operations. The notice shall request that the THP submitter be advised of surface domestic water use from the watercourse, within the THP or within 1,000 feet downstream of the THP boundary. When required to notice by letter publication shall also be given one time by the THP submitter in a newspaper of general circulation in the area affected by the proposed project. Such letter and publication shall notify the party of the proposed timber operation and describe its legal location and identify the name, if any, of the watercourse it may effect. The letter and publication shall request a response by the property owner within ten days of the post-marked date on the letter or the date of publication as appropriate. The RPF may propose, with justification and explanation, an exemption to such notification requirements, and the Director may agree. Copies of either notice, proof of service and publication, and any responses shall be attached to the THP when submitted. If domestic use is noted, the

CALIFORNIA FOREST PRACTICE RULES

plan shall contain mitigations necessary to protect domestic water use. The plan shall not be submitted until ten days after the above notification(s) have been done.

1033 Filing Date

The filing date is the date on which the plan is found by the Director to be accurate, complete, and in proper order.

1034 Contents of Plan

The plan shall serve two functions: to provide information the Director needs to determine whether the proposed timber operation conforms to the rules of the Board; and to provide information and direction to timber operators so that they comply with the rules of the Board. For the plan to serve these functions, it shall, as a minimum, contain the following information:

- (a) Name, address, and telephone number of the timber owner(s).
- (b) Name, address and telephone number of the timberland owner(s).
- (c) Name, address telephone number, and license number of the timber operator(s).
- (d) Name, address, and telephone number of a person to be contacted on the operation who will be responsible for the conduct of the timber operation. If unknown at the time of plan submission, it shall be provided prior to the start of timber operations.
- (e) Name, address, and telephone number of the plan submitter. If the submitter is not a person indicated in (a), (b), or (c) above, an explanation of his/her authority to submit the plan shall be provided.
- (f) Name, address, telephone number, and registration number of RPF who prepared the plan. The plan required for timberland conversion does not have to be prepared by an RPF, [ref. PRC 4622].
- (g) A description of the plan area within which timber operations are to be conducted. The description shall include the following:
 - (1) U.S. Geological Survey (USGS) Quadrangle name(s) and date(s),
 - (2) township, range, and section number(s),
 - (3) county name(s),
 - (4) CALWATER 2.2 planning watershed number(s), and
 - (5) approximate acreage.
- (h) The forest district and subdistrict (if any) in which the timber operation is located.
- (i) Whether a timberland conversion certificate is in effect, its date of expiration, and its identification number.
- (j) Whether a plan is on file with the Department for any part of the plan area for which a Report of Satisfactory Stocking has not been issued by the Department (show plan number).
- (k) Expected dates of commencement/completion of timber operations.
- (l) The types of forest products to be harvested and if management of broadleaf or optional species is being proposed.
- (m) Identity of the regeneration methods, intermediate treatments, special harvesting methods, alternative prescriptions, and any information specified by the district rules. Also for THPs that do not reference an approved Sustained Yield Plan, or do not demonstrate achievement of MSP pursuant to 913.11(c), the following applies:
 - (1) The plan shall provide a description of the stand before and after harvesting including: volume, growth projection, stocking, and species composition.
 - (2) The Director may require such additional information as necessary and feasible to demonstrate how maximum sustained production of high quality timber products will be achieved for an ownership within a THP.
- (n) Type of yarding (logging) systems and equipment to be used. Yarding systems will be placed in one or more of the following groups:
 - (1) Animal
 - (2) Tractor, skidder, forwarder

CALIFORNIA FOREST PRACTICE RULES

- (3) Cable
 - (A) Ground-lead
 - (B) High-lead
 - (C) Skyline
- (4) Balloon, helicopter
- (5) Other, as explained in the plan
- (o) Explanation and location of new roads wider than single lane with turnouts.
- (p) Whether the RPF has informed the timber owner, timberland owner and timber operator of their responsibilities for compliance with the stocking requirements of the Act and rules, and for maintenance of erosion control structures.
- (q) Whether the RPF will be supplying the timber operator with a copy of the approved THP.
- (r) How the requirements of 14 CCR 1032.7(f) are to be met.
- (s) If an archaeological survey has been made on the area to be harvested.
- (t) If there are any recorded archaeological or historical sites in the area to be harvested, and how the sites are to be protected if they exist.
- (u) Where the timber owner or timberland owner has not signed the plan, indication that written notice of such plan has been given to either or both of these persons, as required by 14 CCR 1032.7(b).
- (v) Whether there are any adverse insect, disease, or pest problems in the plan area and what mitigating measures, if any, will be used to improve the health and productivity of the stand.
- (w) Information on the presence and protection of known habitat or individuals of any listed species and information on the presence and protection of non-listed species which may be significantly impacted by the timber operation.
- (x) On titled USGS (if available) or equivalent topographic maps of a scale not less than 2" to the mile, the information in subsections (1-4), (8), (9), and (11-13) shall be clearly shown. Additional maps, which may be topographic or planimetric, may be used to provide the information required in the other subsections or show specific details, to improve map clarity. The appurtenant roads referenced in subsection (4) may be shown on a map which may be planimetric with a scale as small as one-half inch equals one mile. Color coding shall not be used. A legend shall be included indicating the meaning of the symbols used. See the district rules for the appropriate minimum mapping acreages.
 - (1) Boundaries of logging area (shall be shown on quadrangle map or its equivalent).
 - (2) Boundaries of regeneration methods, intermediate treatments, special harvesting methods, and alternative prescriptions that are to be applied.
 - (3) Boundaries of yarding (logging) systems, if more than one system is to be used.
 - (4) Location of public roads and those private roads to be used for timber operations within the plan area, and private roads appurtenant to the timber operations where such roads are under the ownership or control of the timber owner, timberland owner, timber operator, or submitter of the plan, and classification of all proposed and existing logging roads as permanent, seasonal, or temporary roads.
 - (5) Probable location of proposed and existing landings in the watercourse and lake protection zone, and landings outside the zone that are greater than 1/4 acre in size or whose construction involves substantial excavation.
 - (6) Road failures on existing roads to be reconstructed.
 - (7) Location of all watercourse crossing of classified watercourses except temporary crossings of Class III watercourses without flowing water during timber operations at that crossing.
 - (8) Location of erosion hazard rating areas, if more than one rating exists.
 - (9) Location of all watercourses with Class I, II, III, or IV waters.
 - (10) Location of known unstable areas or slides.
 - (11) Location of understocked areas prior to timber operations, and other areas not normally bearing timber to at least a 20-acre minimum, or as specified in the district rules.
 - (12) Location of boundaries of timber-site classes needed for determination of stocking standards to be applied, down to at least a 20-acre minimum or as specified in the district rules.
 - (13) Location of main ridge tops on the logging area suitable for fire suppression efforts that will require the felling of snags.
 - (14) Location of Coastal Commission Special Treatment Areas or any special treatment area.

CALIFORNIA FOREST PRACTICE RULES

(15) Location for which heavy equipment use is proposed on unstable areas, or on areas for which tractor use is proposed beyond the limitations of the standard forest practice rules.

(16) Location of any in lieu use of heavy equipment and location of roads other than crossings in the WLPZ, marshes, wet meadows, and other wet areas.

(17) Location of any new or reconstructed road segment(s) that exceed an average 15% grade for over 200 feet.

(y) Any additional information that is submitted on separate pages shall be clearly marked "plan addendum" and shall bear the date on which it was prepared.

(z) Explanation and justification for, and specific measures to be used for tractor operations on unstable areas, on slopes over 65%, and on areas where slopes average over 50% and the EHR is high or extreme.

(aa) Explanation and justification for tractor operations in areas designated for cable yarding.

(bb) Winter period operating plan where appropriate.

(cc) Explanation and justification for use of watercourse, marshes, wet meadows, and other wet areas as landings, roads, or skid trails.

(dd) Explanation and justification of any in-lieu practices for watercourse and lake protection.

(ee) Explanation of alternatives to standard rules for harvesting and erosion control.

(ff) Explanation and justification for landings that exceed the maximum size specified in the rules.

(gg) Any other information required by the rules or the Act to be included in the plan. The district rules provide for exceptions and alternatives to standard requirements that require inclusion of information in the THP.

(hh) Where roads, watercourse crossings, and associated landings in the logging area will be abandoned, the methods for abandonment shall be described.

(ii) On a map complying with subsection 1034(x), the locations and classifications of roads, watercourse crossings, and landings to be abandoned shall be shown.

(jj) A general description of physical conditions at the plan site, including general soils and topography information, vegetation and stand conditions, and watershed and stream conditions.

1034.2 Professional Judgment

Where the rules or these regulations provide for the exercise of professional judgment by the forester (RPF) or the Director, the parties, at the request of either party shall confer on the plan area during the initial pre-harvest inspection provided for by law to reach agreement if possible on the conditions and standards to be included in the plan.

1035 Plan Submitter Responsibility

The plan submitter, or successor in interest, shall:

(a) Ensure that an RPF conducts any activities which require an RPF.

(b) Provide the RPF preparing the plan or amendments with complete and correct information regarding pertinent legal rights to, interests in, and responsibilities for land, timber, and access as these affect the planning and conduct of timber operations.

(c) Sign the THP certifying knowledge of the plan contents and the requirements of this section.

(d) (1) Retain an RPF who is available to provide professional advice to the LTO and timberland owner upon request throughout the active timber operations regarding:

A) the plan,

B) the Forest Practice Rules, and

C) other associated regulations pertaining to timber operations,

(2) The plan submitter may waive the requirement to retain an RPF to provide professional advice to the LTO and timberland owner under the following conditions:

A) the plan submitter provides authorization to the timberland owner to provide advice to the LTO on a continuing basis throughout the active timber operations provided that the timberland owner is a natural person who personally performs the services of a professional forester and such services are personally performed on lands owned by the timberland owner;

B) the timberland owner agrees to be present on the logging area at a sufficient frequency to know the progress of operations and advise the LTO, but not less than once during the life of the plan; and

CALIFORNIA FOREST PRACTICE RULES

C) the plan submitter agrees to provide a copy of the portions of the approved THP and any approved operational amendments to the timberland owner containing the General Information, Plan of Operations, THP Map, Yarding System Map, Erosion Hazard Rating Map and any other information deemed by the timberland owner to be necessary for providing advice to the LTO regarding timber operations.

(3) All agreements and authorizations required under 14 CCR § 1035(d)(2) shall be documented and provided in writing to the Director to be included in the plan.

(e) Within five working days of change in RPF responsibilities for THP implementation or substitution of another RPF, file with the Director a notice which states the RPF's name and registration number, address, and subsequent responsibilities for any RPF required fieldwork, amendment preparation, or operation supervision. Corporations need not file notification because the RPF of record on each document is the responsible person.

(f) Provide a copy of the portions of the approved THP and any approved operational amendments to the LTO containing the General Information, Plan of Operations, THP Map, Yarding System Map, Erosion Hazard Rating Map and any other information deemed by the RPF to be necessary for timber operations .

(g) Notify the Director prior to commencement of site preparation operations. Receipt of a burning permit is sufficient notice.

(h) Disclose to the LTO, prior to the start of operations, through an on-the-ground meeting, the location and protection measures for any archaeological or historical sites requiring protection if the RPF has submitted written notification to the plan submitter that the plan submitter needs to provide the LTO with this information.

1035.1 Registered Professional Forester Responsibility

(a) Upon submission of a THP, the RPF who prepares and signs a plan is responsible for the accuracy and completeness of its contents.

(1) The RPF preparing the plan shall state in the THP the work which will be performed by the RPF plan preparer (beyond preparation of the THP and attending the pre-harvest inspection if requested by the Director), and any additional work requiring an RPF which the plan preparer does not intend to perform. This may include, but is not limited to, field work in identifying watercourse and lake protection zones or special treatment areas, marking trees, or other activities. The RPF is only responsible for the activities set forth in the plan when employed for that purpose, or required by the rules of the Board. The RPF shall state whether or not he or she has been retained to provide professional advice throughout the timber operations.

(2) The RPF preparing the plan shall in writing, inform the plan submitter(s) of their responsibility pursuant to Section 1035 of this Article, and the timberland owner(s) of their responsibility for compliance with the requirements of the Act and where applicable, Board rules regarding site preparation, stocking, and maintenance of roads, landings, and erosion control facilities.

(b) Upon entering into an agreement to accept responsibility for any part of the preparation or implementation of a plan or any work beyond the preparation of a plan, including providing professional advice; all responsible RPFs shall disclose to the real party of interest for whom the RPF is providing professional forestry services any known current or potential conflict of interest the RPFs have with regard to the timber or land that is subject to operations under the plan. All responsible RPFs shall disclose to the timberland owner and plan submitter whether they are the real party of interest for whom the RPF is providing professional forestry services.

(c) Disclosure of newly discovered conflicts of interest an RPF has with regard to the plan submitter, timberland owner, timber owner, the LTO and timber purchaser, pertaining to the timber or land that is subject to operations under the plan, shall be required as long as an RPF has responsibilities relative to a plan. The disclosure shall include identification of the real party of interest for whom the RPF is providing professional forestry services.

(d) All disclosures made between an RPF and an affected party pursuant to this section may be kept confidential.

(e) An RPF retained by the plan submitter to provide professional advice throughout the timber operations shall be present, or ensure that the RPF's supervised designee is present, on the logging area at a sufficient frequency to know the progress of operations and advise the LTO and timberland owner, but not less than once during the life of the plan.

CALIFORNIA FOREST PRACTICE RULES

(f) An RPF retained by the plan submitter to provide professional advice throughout the timber operations shall inform the LTO during operations of any mitigation measures incorporated into the plan that are intended to address operations that have a high likelihood of resulting in immediate, significant and long-term harm to the natural resources of the State if such mitigation measures are not strictly applied to minimize such impacts.

(g) The RPF shall without delay notify in writing the LTO, the plan submitter, and the Department of a decision to withdraw professional services from the plan.

1035.2 Interaction Between RPF and LTO

After the start of the plan preparation process but before commencement of operations, the responsible RPF or supervised designee familiar with on-site conditions, shall meet with either the LTO, or supervised designee, who will be on the ground and directly responsible for the harvesting operation. The meeting shall be on-site if requested by either the RPF or LTO. An on-site meeting is required between the RPF or supervised designee familiar with on-site conditions and LTO to discuss protection of any archaeological or historical sites requiring protection if any such sites exist within the site survey area pursuant to Section 929.2[949.2,969.2](b). If any amendment is incorporated to the plan by an RPF after the first meeting, that RPF or supervised designee familiar with on-site conditions shall comply with the intent of this section by explaining relevant changes to the LTO; if requested by either that RPF or LTO, another on-site meeting shall take place. The intent of any such meeting is to assure that the LTO:

(a) Is advised of any sensitive on-site conditions requiring special care during operations.

(b) Is advised regarding the intent and applicable provisions of the approved plan including amendments.

1035.3 Licensed Timber Operator Responsibilities

Each affected licensed Timber Operator shall:

(a) Sign the plan and major amendments to the plan, or sign and file with the Director a facsimile of such plan or amendments, agreeing to abide by the terms and specifications of the plan. This shall be accomplished prior to implementation of the following; which the affected LTO has responsibility for implementing:

1) those operations listed under the plan and

2) those operations listed under any amendments proposing substantial deviations from the plan.

(b) Inform the responsible RPF or plan submitter, whether in writing or orally, of any site conditions which in the LTO's opinion prevent implementation of the approved plan including amendments.

(c) Be responsible for the work of his or her employees and familiarize all employees with the intent and details of the operational and protection measures of the plan and amendments that apply to their work.

(d) Keep a copy of the applicable approved plan and amendments available for reference at the site of active timber operations. The LTO is not required to possess any confidential addenda to the plan such as the Confidential Archaeological Addendum, nor is the LTO required to keep a copy of such confidential plan addenda at the site of active timber operations.

(e) Comply with all provisions of the Act, Board rules and regulations, the applicable approved plan and any approved amendments to the plan.

(f) In the event that the LTO executing the plan was not available to attend the on-site meeting to discuss archaeological site protection with the RPF or supervised designee familiar with on-site conditions pursuant to Section 929.2 [949.2,969.2] (b), it shall be the responsibility of the LTO executing the plan to inquire with the plan submitter, timberland owner, or their authorized agent, RPF who wrote the plan, or the supervised designee familiar with on-site conditions, in order to determine if any mitigation measures or specific operating instructions are contained in the Confidential Archaeological Addendum or any other confidential addendum to the plan.

(g) Provide the RPF responsible for professional advice throughout the timber operations an on-site contact employee authorized by the LTO to receive RPF advice.

(h) Keep the RPF responsible for professional advice throughout the timber operations advised of the status of timber operation activity.

(i) Within five days before, and not later than the day of the start-up of a timber operation, the LTO shall notify the RPF of the start of timber operations.

CALIFORNIA FOREST PRACTICE RULES

(2) Within five days before, and not later than the day of the shutdown of a timber operation, the LTO shall notify the RPF of the shutdown of timber operations.

(A) The notification of the shutdown of timber operations is not required if the period of the shutdown does not extend beyond a weekend, including a nationally designated legal holiday.

(i) Upon receipt of written notice of an RPF's decision to withdraw professional services from the plan, the LTO or on-site contact employee shall cease timber operations, except for emergencies and operations needed to protect water quality, until the LTO has received written notice from the plan submitter that another RPF has visited the plan site and accepts responsibility for providing advice regarding the plan as the RPF of record.

1035.4 Notification of Commencement of Operations

Each calendar year, within fifteen days before, and not later than the day of the start up of a timber operation, the Timber Harvesting Plan Submitter unless the THP identifies another person as responsible, shall notify CDF of the start of timber operations. The notification, by telephone or by mail, shall be directed to the appropriate CDF Ranger Unit Headquarters, Forest Practice Inspector, or other designated personnel.

1036 Deviations (Relocated to 895.1 Definitions)

1036.1 Murrelet Protection before Notice of Completion

For any THP which has been found to be in conformance with THP filing and review procedures and approved by the Director, but as to which no Notice of Completion (PRC Sec. 4586) has been filed, when there is evidence that the THP area contains an active murrelet site or possesses a potential impact to a murrelet, the THP submitter shall immediately request a conference with DFG or U.S. Fish and Wildlife Service (in the event of Federal listing) to determine appropriate measures for protection of the species. Any additional mitigations for species protection which are developed through consultation with DFG or the U.S.F.W.S after initial submittal of the THP shall be submitted to the Director in the form of an amendment to the THP pursuant to 14 CCR 1036.

1037 THP Preharvest Inspection-Filing Return

Within ten (10) days of the receipt of a plan, the Director shall determine if the plan is accurate, complete and in proper order, and if so, the plan shall be filed. During this same period, the Director shall determine if a preharvest inspection is necessary. When the Director finds a plan inaccurate, incomplete or otherwise not in proper order, the plan shall be returned to the submitter with written specifications of the deficiencies.

If a preharvest inspection is to be held, the LTO who will operate under the plan, if known, shall be invited to participate.

1037.1 Notice of Filing

(a) The Director shall prepare a notice of filing which shall contain the basic information contained in the Notice of Intent (14 CCR 1032.7) plus the assigned timber harvesting plan number.

(b) Within two working days of the date the plan is filed, the Director shall transmit copies of the Notice of Filing to:

- (1) The person submitting the plan.
- (2) The office of the County Clerk of the county in which the operations are proposed. The notice shall be posted at the normal place for posting environmental notices.
- (3) The local Ranger Unit headquarters for posting.
- (4) At such other locations as the Director may deem desirable and feasible to provide adequate public notice.
- (5) All public agencies having custodial responsibility for lands within 91.44 m. (300 ft.).
- (6) Anyone else, as required by Public Resources Code Sections 4582.4 and 4582.6.

CALIFORNIA FOREST PRACTICE RULES

1037.3 Agency and Public Review

(a) Upon receipt of the filed plan in accordance with 14 CCR 1037, the Director shall place it, or a true copy thereof, in a file available for public inspection, and shall transmit a copy to the Department of Fish and Game, the appropriate California Regional Water Quality Control Board, the Department of Conservation, Division of Mines and Geology, the Department of Parks and Recreation, the county planning agency and, if the areas are within their jurisdiction, to the California Tahoe Regional Planning Agency and the California Coastal Commission.

(b) The Director shall also transmit a copy of any specific plan to any person who has made a written request therefor.

(c) The Department shall bill such persons for the cost of providing such copies and such monies shall be paid to the Department.

The Director shall invite written comments, and will consider these comments. All comments regarding plans shall be in writing and shall be addressed to the Director at the regional office where the plan is filed. Comments from reviewing public agencies shall be considered based on the comments' substance, and specificity, and in relation to the commenting agencies' area(s) of expertise and statutory mandate, as well as the level of documentation, explanation or other support provided with the comments.

1037.4 Director's Determination

The Director shall have 15 days from the date the initial inspection is completed, or in the event the Director determines that such inspection need not be made, 15 days from the date of filing of an accepted plan in accordance with 14 CCR 1037, or such longer period as may be mutually agreed upon by the Director and the person submitting the plan, to review the plan and take public comment. After the initial review and public comment period has ended, the Director shall have up to ten working days, or a longer period mutually agreed upon by the Director and the person submitting the plan, to review the public input, to consider recommendations and mitigation measures of other agencies, to respond in writing to the issues raised and to determine if the plan is in conformance with the applicable rules adopted by the Board. The Director shall insure that an interdisciplinary review team has had an opportunity to review each plan. The Director shall review and consider the recommendations made on each plan by the interdisciplinary review team before determining if the plan conforms to the rules of the Board. The Director shall consider all written comments regarding the plan.

1037.5 Review Teams to be Established

Interdisciplinary review teams shall be established by the Director to review plans and assist the Director in the evaluation of proposed timber operations and their impacts on the environment.

(a) Review Team Composition: Each review team, when possible, shall consist of a representative from each of the following agencies: the appropriate California Regional Water Quality Control Board, Department of Fish and Game, Department of Conservation, Division of Mines and Geology, a representative of county government when the county government so requests, California Coastal Commission (for plans in the coastal zone), California Tahoe Regional Planning Agency (for plans in the Tahoe Basin) and the Department of Forestry and Fire Protection. The Director shall request a representative from the Department of Parks and Recreation in the case of plans that may affect values in publicly owned parks. The Director may request other federal, state or county agencies, or the Native American Heritage Commission (NAHC) or local tribal groups identified by the NAHC, when appropriate, to assist as advisors in the review process. The Department's representative shall be the review team Chairperson and shall be an RPF.

(b) Review Team Function: The function of the review team shall be to assist the Director in determining if plans are in conformance with Board rules and to evaluate the potential environmental impacts of timber operations. Review criteria employed by a team shall be consistent with this function. The Board's regulations provide direction for those situations noted during the review which are not addressed by specific rules (14 CCR 898.1(f), 901-903.2, 1655 & PRC 4555). In evaluating a plan, the review team shall review any discussion of feasible alternatives or additional mitigation to the proposed timber operation as prescribed in 14 CCR 898. Plan reviewers must consider the economic as well as the environmental benefits of feasible alternatives. The review team shall serve in an advisory capacity to the Director in making recommendations on plans.

CALIFORNIA FOREST PRACTICE RULES

In the event that any member of the review team concludes that the plan as filed would have a significant adverse effect on the environment, that member shall explain and justify this conclusion in writing as specifically as possible. The member shall provide in writing suggested site-specific mitigation measures, if any, that will substantially lessen the impacts.

(c) **Chairperson Tasks:** The Department is the lead agency in the review of plans. The review team chairperson shall direct the review team meetings, coordinate the interdisciplinary review of plans and develop recommendations on plans for the Director's consideration.

(d) **Review Team Meetings.** The Director or his designee is responsible for establishing and scheduling the meeting of a review team to perform the necessary review of plans for the Department.

Review team meetings shall be open to the RPF, supervised designee, the landowner, and the timber owner and, insofar as possible without disrupting the work of the team, to the public. The chairperson may impose limitations on the scope of any public participation at the meetings. All interested persons will normally be allowed to attend team meetings. On occasions when space or other considerations will require some limitation on attendance the review team chairperson shall endeavor to allow for attendance of at least one representative for each of the various agencies, organizations or special interest groups.

(e) **Non-Concurrence:** If a member of the review team does not concur with the chairperson's recommendation to the Director, the member shall submit in writing, within five days of the review team meeting and before the action required by 14 CCR 1037.4, the specific reasons why the recommendation does not provide adequate protection of the resources for which his or her agency has responsibility. The submission to the Director shall also include recommendations on measures or actions the Director should take to address the asserted deficiency, as provided by the rules of the Board. A non-concurring member's comments shall be considered based on the comment's specificity and relation to the member agency's area(s) of expertise and statutory mandate, as well as the level of documentation, explanation or other support provided with the comments. If a non-concurrence is filed on a plan, the review team chairperson shall prepare a written report explaining how the concerns cited in the non-concurrence have been addressed in the plan and how the natural resources of concern will be protected during timber operations.

(f) **Mitigation:** Mitigation and protective measures developed by members of the review team shall be consistent with 14 CCR 1037.3, 1037.5(b), 1037.5(h), and PRC 4582.6(b). Unless the RPF and review team member agree to mitigation measure(s), such mitigation and protective measures shall be explained and justified in writing and be based upon the evaluation of site-specific conditions at the appropriate scale.

(1) During the review of a plan, including the pre-harvest inspection, members of the review team may recommend incorporation of mitigating measures into the plan which are consistent with the forest practice rules and which would improve the plan or assist in significantly lessening adverse impacts of the operation on any timberland resources. The submitter may or may not agree with concerns expressed by the suggestions or may offer alternatives. If the submitter, after consultation with the RPF who prepared the plan, agrees with the suggested mitigation measures or changes, they are to be incorporated in the plan. The Director may only require incorporation into the plan of mitigation measures that are based on rules of the Board.

(2) Members of the review team may suggest protective measures for incorporation into the plan when authority for such measures is not contained in the rules and regulations of the Board. If the RPF rejects incorporation of such measures into the plan, the Director shall determine if approval of the plan without the suggested measures could result in immediate significant, and long-term harm to the natural resources of the state. If the Director finds that the state's resources are so endangered, the provisions of PRC 4555 shall be followed.

(g) **Review of Plans by Review Teams:** Before the Director makes a determination on a plan, a review team shall review the plan. The review team shall do the following:

(1) Before the Director accepts a plan for filing or before the fifth working day after filing, a review team shall review the plan. The purpose of this review is to assist this Department in determining whether a preharvest inspection (initial inspection) is necessary and what areas of concern are to be examined during the inspection, if it is to be made. If a preharvest inspection is determined by the Department to be unnecessary, the review team shall make its recommendation to the Director no later than five working days after a plan is filed.

(2) After the preharvest inspection and before the Director's determination on a plan, the review team shall meet to review all the information on the plan and develop a recommendation for the Director.

CALIFORNIA FOREST PRACTICE RULES

(3) Requests, if any, for additional information, from the plan submitter during the review period shall be as prescribed by Section 1034 and other conditions in the rules. Such requests shall be supported by reasons for the request. During the review period, the Director shall be responsible for determining whether requests for information not contained in the plan as filed or developed in preharvest inspection by review team members, reviewing agencies and members of the public, are consistent with the Forest Practice Rules, are reasonably necessary and should be requested from plan submitters. The Director's determination of additional information to be provided by plan submitters shall be guided by standards of practicality and reasonableness, recognizing the statutory review period of the FPA, the requirements of 14 CCR 1034 and the availability of information from alternative sources.

(h) Review Team Recommendations: The review team chairperson shall develop for each plan reviewed, a recommendation for the Director's consideration. When developing recommendations the review team chairperson shall carefully consider all the information available and the views and opinions expressed by all team members. The advice of review team members shall be utilized in determining whether appropriate alternatives have been selected and included in a plan and if implementation of the plan would cause significant damage to natural resources. The Director shall evaluate the review team recommendation in light of their specificity, as well as the level of documentation, explanation or other support provided with the recommendation and the agency's statutory mandates and areas of expertise.

(i) Communications with Plan Submitter: The plan submitter, and the RPF who prepared the plan, and review team members, shall be provided by the Department with copies of preharvest inspection reports, nonconcurrences and review team recommendations so they are kept informed and are better able to respond promptly to the Department relative to changes that may be needed in a plan before it is acted upon by the Director.

1037.6 Nonconformance of Plan

If the Director determines that a plan is not in conformance with the rules of the Board the plan shall be returned in accordance with 14 CCR 1054. In addition, the Director shall state any changes and reasonable conditions that in the Director's professional judgment are needed to bring the plan into conformance with the applicable rules of the Board and offer to confer with the RPF in order to reach agreement on the conditions necessary to bring the plan into conformance.

1037.7 Conformance of Plan

If the Director determines that the plan is in conformance with the rules of the Board, then the person submitting the plan shall be notified, and timber operations thereunder may commence.

1037.8 Notice of Conformance

At the time the Director notifies the plan submitter that the plan has been found in conformance, as described in 14 CCR 1037.7, the Director shall transmit a notice thereof to the agencies and persons referred to in 14 CCR 1037.3, and for posting at the places named in 14 CCR 1037.1. A copy of the notice shall be filed with the Secretary for Resources. The notice of conformance shall include a written response of the Director to significant environmental issues raised during the evaluation process.

1037.9 Public Inspection

Notices of Conformance, pursuant to 14 CCR 1037.7 and notices of approval by the Board, pursuant to 14 CCR 1037.6, shall be available for public inspection and a list of such notices shall be posted on a weekly basis in the Office of the Resources Agency. Each such list shall remain posted for a period of 30 days.

1037.10 Review Period Waiver

In counties for which rules and regulations have been adopted pursuant to Section 4516.5, no timber harvesting plan shall be approved by the Director until 35 days from the date of filing of the plan unless the Director finds that the proposed timber operations will cause no significant environmental damage or threat to public health and safety or the environment or that the timber operations are necessary to reduce such a threat. The Director may waive or shorten the time period for approval:

(a) If all of the following are true of the plan:

(1) No new road construction;

CALIFORNIA FOREST PRACTICE RULES

- (2) No road reconstruction that involves substantial change in the original road prism;
- (3) No timber operations on slopes in excess of 60%;
- (4) No timber operations in special treatment areas;
- (5) No timber operations within watercourse and lake protection zones;
- (6) No timber operations on unstable soils;
- (7) No timber operations within 500 ft. of an active nesting site rare or endangered bird species;
- (8) No timber operations on areas with high or extreme erosion hazard rating;
- (9) The harvest area will be stocked at completion of timber operations;
- (10) No threat to public safety is involved; and
- (11) No public hearing has been requested by the county.

(b) Or if the Director finds that he or she must approve a plan quickly so as to adequately protect the public health and safety, or the environment and that such protection cannot be adequately provided under the normal rules of the Board for plan review. The basis for the finding must be stated in writing before the Timber Harvesting Plan is approved.

1037.11 Notice of Waiver

If the Director decides to waive or shorten the time period for plan review pursuant to 14 CCR 1037.10, he or she shall give notice within three working days of that determination to all persons or agencies to whom a Notice of Intent was sent.

1038 Exemption

Persons who conduct the following types of timber operations are exempt from the plan preparation and submission requirements (PRC 4581) and from the completion report and stocking report requirements (PRC 4585 and 4587) of the Act except no tree that existed before 1800 A.D and is greater than sixty (60) inches in diameter at stump height for Sierra or Coastal Redwoods, and forty-eight (48) inches in diameter at stump height for all other tree species shall be harvested unless done so under the conditions or criteria set forth in subsection 1038 (h):

- (a) Harvesting Christmas trees.
- (b) Harvesting dead, dying or diseased trees of any size, fuelwood or split products in amounts less than 10% of the average volume per acre when the following conditions are met:
 - (1) No tractor or heavy equipment operations on slopes greater than 50%.
 - (2) No construction of new tractor roads on slopes greater than 40%.
 - (3) Timber operations within any Special Treatment Area, as defined in 14 CCR 895.1, shall comply with the rules associated with that Special Treatment Area.
 - (4) No tractor or heavy equipment operations on known slides or unstable areas.
 - (5) No new road construction or reconstruction, as defined in 14 CCR 895.1.
 - (6) No heavy equipment operations within the standard width of a watercourse or lake protection zone, as defined in 14 CCR 916.4 [936.4, 956.4](b), except for maintenance of roads and drainage facilities or structures.
 - (7) No known sites of rare, threatened or endangered plants or animals will be disturbed, threatened or damaged.
 - (8) No timber operations within the buffer zone of a sensitive species, as defined in 14 CCR 895.1.
 - (9) No timber harvesting within the standard width of a watercourse or lake protection zone, as defined in 14 CCR 916.4 [936.4, 956.4](b), except sanitation-salvage harvesting, as defined in 14 CCR 913.3 [933.3, 953.3], where immediately after completion of operations, the area shall meet the stocking standards of 14 CCR 912.7 [932.7, 952.7](b)(2), or, except the removal of dead or dying trees where consistent with 14 CCR 916.4 [936.4, 956.4] (b). Trees to be harvested shall be marked by, or under the supervision of, an RPF prior to timber operations.
 - (10) No timber operations on any site that satisfies the criteria listed in 895.1 for a significant archaeological or historical site. Information on some of these sites may be available from the Information Centers of the California Historical Resources Information System within the Department of Parks and Recreation.
- (c) The cutting or removal of trees in compliance with sections 4290 and 4291 which eliminates the vertical continuity of vegetative fuels and the horizontal continuity of tree crowns for the purpose of reducing

CALIFORNIA FOREST PRACTICE RULES

flammable materials and maintaining a fuelbreak to reduce fire spread, duration, and intensity.

(1) Only trees within one-hundred-fifty feet from any point of an approved and legally permitted structure that complies with the California Building Code may be harvested.

(2) The following silvicultural methods may not be used: clearcutting, seed tree removal step, shelterwood removal step.

(3) All surface fuels created by timber operations under the exemption which could promote the spread of wildfire, including logging slash and debris, deadwood, branches exceeding 1 inch in diameter, and brush, shall be chipped, burned, or removed within 45 days from the start of timber operations.

(4) In addition to the slash treatment described in CCR 1038(c)(3), the areas of timber operations must meet the vegetation treatment standards in PRC 4584(j)(1) to (2)(A) illustrated in Technical Rule Addendum No.4 within one year from the receipt of issuance of Notice of Acceptance.

(5) In addition to the limitations listed in 1038(b)(1)-(10), the following apply:

(A) The timber operator shall provide the Director the tentative commencement date of timber operations on the notice required in 14CCR 1038.2. Within a 15 day period before beginning timber operations, the timber operator shall notify CDF of the actual commencement date for the start of operations. The starting date shall be directed to the designated personnel at the appropriate CDF Ranger Unit Headquarters by telephone or by mail.

(B) Timber operations conducted under this subsection shall conform to applicable city or county general plans, city or county implementing ordinances, and city or county zoning ordinances within which the exemption is located. The timber operator or timberland owner shall certify that the city or county has been contacted and the exemption conforms with all city or county regulatory requirements.

(C) Timber operations may not be conducted without a copy of the Director's notice of acceptance of the exemption at the operating site, except where the Director has failed to act within the 5 working-day review period.

(d) The limit of 10% of the volume per acre in (b) above does not apply when harvesting dead trees which are unmerchantable as sawlog-size timber from substantially damaged timberlands, as defined in 14 CCR 895.1, and the following conditions are met:

(1) Timber operations shall comply with the limits established in 14 CCR 1038(b)(1)-(10).

(2) The landowner shall notify the Director of the completion of timber operations within 30 days of their cessation.

(3) At least one inspection conducted by the Director shall be made after completion of operations (Section 4604 PRC).

(4) The RPF certifies that the timberland is substantially damaged.

(5) The RPF shall also certify that no conditions were identified where operations, conducted in compliance with the rules of the Board, would reasonably result in significant adverse effects.

(e) Operations pursuant to an exemption under subsection (c) and (d) may not commence for five working days from the date of the Director's receipt of the exemption unless this delay is waived by the Director after consultation with other state agencies. The Director shall determine whether the exemption is complete, and if so, shall send a copy of a notice of acceptance to the submitter. If the exemption is not complete and accurate, it shall be returned to the submitter and the timber operator may not proceed. If the Director does not act within five days of the receipt of the exemption, timber operations may commence.

(f) On parcels of 20 acres or less in size within the Lake Tahoe Basin, that are not part of a larger parcel of land in the same ownership, the removal of dead or dying, (regardless of the definition of "dying trees" in section 895.1, dying means: will be dead within 1 year, based on the judgement of an RPF) as marked by an RPF and for which a Tahoe Basin Tree Removal Permit has been issued, when the following conditions are met:

(1) Tree removal on high erosion hazard lands (Bailey's Land Capability Districts 1a, 1c, or 2 per Land Capability Classification of the Lake Tahoe Basin, California-Nevada: A Guide for Planning by R.G. Bailey, USDA Forest Service, 1974) shall only be conducted using the following methods: helicopter, over-snow where no soil disturbance occurs, hand carry, and use of existing roads.

(2) Tree removal in Stream Environment Zones ("SEZs", Bailey's Land Capability District 1b) shall be permitted as in the preceding section (f)(1). End-lining may also be used provided that soils are dry, all heavy equipment remains outside the SEZ, and site conditions are such that soils or vegetation will not be adversely affected and a discharge of earthen materials to surface waters, SEZs, or 100-year floodplains will

CALIFORNIA FOREST PRACTICE RULES

not occur.

(3) No tractor or heavy equipment (ground-based) operations on slopes greater than 30% except during over-snow operations that result in soil disturbance.

(4) No heavy equipment operations within the standard width of a watercourse or lake protection zone (WLPZ), as defined in 14 CCR 956.4(b), except for use or maintenance of existing roads, maintenance of drainage facilities or structures, or use of skid crossings approved pursuant to (f)(9) below.

(5) No new road construction or reconstruction, as defined in 14 CCR 895.1.

(6) No tractor or heavy equipment operations on known slides or unstable areas.

(7) No timber harvesting within the standard width of a watercourse or lake protection zone, as defined in 14 CCR 956.4(b), except sanitation-salvage harvesting, as defined in 14 CCR 953.3, where immediately after completion of operations, the area shall meet the stocking standards of 14 CCR 952.7(b)(2), or, except the removal of dead or dying trees where consistent with 14 CCR 956.4 (b). Trees to be harvested shall be marked by, or under the supervision of, an RPF prior to timber operations.

(8) All Class III watercourses shall have at least 25-foot WLPZ.

(9) No watercourse crossings of Class I or Class II watercourses except on existing bridges or existing culvert crossings. Any and all crossings proposed for Class III or Class IV watercourses shall be approved by staff of the Regional Water Quality Control Board (RWQCB) prior to operations.

(10) No known sites of rare, threatened or endangered plants or animals will be disturbed, threatened or damaged.

(11) No timber operations within the buffer zone of a sensitive species, as defined in 14 CCR 895.1.

(12) No timber operations on historical or archaeological sites. Information on some of these sites may be available from the Information Centers of the California Historical Resources Information System within the Department of Parks and Recreation.

(13) The landowner shall allow access to the property for inspections by staff of the RWQCB.

(14) A person shall comply with all operational provisions of the Forest Practice Act and District Forest Rules applicable to "Timber Harvest Plan", "THP", and "plan".

(15) Subsection (f) shall expire December 31, 2002.

(g) The removal of woody debris and slash that is: (1) located outside the standard width WLPZ; (2) within the reach of loading equipment operating on existing logging roads, and landings; (3) developed during timber operations; and (4) delivered as combustion fuel for the production of energy. Timber operations under this subsection shall comply with the conditions of section 1038 (b) (3), (4), (6), (7), (8), and (10).

(h) Harvesting of large old trees shall only occur when:

(1) the tree is not critical for the maintenance of a Late Successional Stand and

(2) an RPF attaches to the exemption an explanation and justification for the removal based on the RPF's finding that one or more of the criteria or conditions listed under subsection (A), (B), or (C) are met.

The requirements of (h)(2) need not be met if an approved management document; including but not limited to a HCP, SYP, NTMP or PTEIR; addresses large old tree retention for the area in which the large old tree(s) are proposed for removal and the removal is in compliance with the retention standards of that document.

All trees to be harvested pursuant to this subsection shall be marked by an RPF prior to removal.

(A) The tree(s) is a hazard to safety or property. The hazard shall be identified in writing by an RPF or professionally certified arborist;

(B) The removal of the tree(s) is necessary for the construction of a building as approved by the appropriate county/city permitting process and as shown on the county/city approved site plan which shall be attached to the Notice of Exemption;

(C) The tree is dead or is likely to die within one year of the date of proposed removal, as determined by an RPF or professionally certified arborist.

CALIFORNIA FOREST PRACTICE RULES

BOARD OF FORESTRY TECHNICAL RULE ADDENDUM NO. 4:
ILLUSTRATION OF MINIMUM DISTANCES REQUIRED BY LAW FOR FIRE SAFE THP
VEGETATION TREATMENT, page one of Addendum.

CALIFORNIA FOREST PRACTICE RULES

BOARD OF FORESTRY TECHNICAL RULE ADDENDUM NO. 4:

ILLUSTRATION OF REMOVAL OF LADDER FUELS AND HORIZONTAL CONTINUITY OF
FUELS, page two of Addendum.

CALIFORNIA FOREST PRACTICE RULES

1038.1 Compliance with Act and Rules

A person conducting timber operations under any exemption as described in 1038, shall be limited to one year from the date of receipt by the Department, and shall comply with all operational provisions of the Forest Practice Act and District Forest Practice Rules applicable to "Timber Harvest Plan", "THP", and "plan".

In-lieu practices for watercourse and lake protection zones as specified under Article 6 of these rules, exceptions to rules, and alternative practices are not allowed.

1038.2 Exemption Form

A person submitting an exemption under 14CCR 1038 shall submit to the Director a notice of proposed timber operations, prior to commencement of timber operations, on a form provided by the Department. The form shall contain the following information:

- (a) Type of operation to be conducted.
- (b) Names, address, and telephone numbers of the timber owner, timberland owners, and timber operator.
- (c) Legal description of the location of the timber operation.
- (d) A 7½ minute quadrangle map or its equivalent showing the location of the timber operation.
- (e) In addition to (a) through (d) above, the following shall be included for exemptions conducted under 14CCR 1038(d):
 - (1) The tentative commencement date of timber operations.
 - (2) A certification by the timber operator or timberland owner that the city or county within which the exemption is located has been contacted and the exemption is in conformance with all city or county regulatory requirements.
 - (3) A notification to the landowner stating the fuel treatment requirements and enforcement procedures under this exemption.
 - (4) A signature of the landowner certifying that they are the landowner and have read and understand the information on the exemption form.
 - (5) A larger scale map such as an assessor parcel map showing the location of the timber operation.

1038.3 Agency Exemptions

The following types of timber operations are exempt from the provisions of the Z'berg-Nejedly Forest Practice Act (PRC Section 4511 et. seq.), but not exempt from the Professional Foresters Law, PRC 750 et. seq.

(a) Timber operations on land managed by the California Department of Parks and Recreation, provided the timber operations have undergone all required CEQA evaluation required pursuant to Public Resources Code Div. 13 commencing with Sec. 21000.

(b) Timber operations performed by, or authorized by, federal agencies on private lands where federal easements, either partial interest or in fee, have been acquired, provided such activities are analyzed and conducted pursuant to the National Environmental Policy Act (commencing with 42 USC 4321) and achieve the same level of protection as provided by the rules of the Board (Div. 15, Title 14, CCR).

1039 Amendment

Amendments proposing substantial deviation from an original plan shall be submitted to the Director in writing by the person who submitted the original plan, or the successor in interest. Substantial deviations shall not be undertaken until such amendment has been filed and acted upon by the Director in the manner as required in Article 2 of Subchapter 7 of these rules for the original plan.

1039.1 Effective Period of the Plan

The effective period of the plan within the meaning of PRC 4590 and 4591 is the 3-year period following the date the plan is determined to be in conformance or otherwise becomes effective pursuant to PRC 4582.7. Timber operations shall commence no earlier than the expected date of commencement stated in the plan and shall be completed no later than the expected date of completion stated in the plan except under the following conditions:

- (a) An amendment to change the completion date stated in a plan has been submitted to the Director at least ten days before the expected date of completion.

CALIFORNIA FOREST PRACTICE RULES

(b) An amendment to extend the effective period of a plan beyond three years is submitted in compliance with PRC 4590, which includes a map showing clearly the area pertaining to the request for extension.

Upon receipt of such amendment, the Director shall determine whether the change in date constitutes a substantial deviation of the plan. An extension of time is presumed to be a minor deviation, provided the extension does not lead to practices that constitute a substantial deviation, as defined in Section 1036, 14 CCR. If the Director determines that such change of date constitutes a substantial deviation, then the Director shall, prior to the date to be changed, so notify the person submitting the plan. In this case, an amended plan shall be submitted and no timber operations shall be conducted pursuant to such proposed change until such amendment is found in conformance with PRC 4582.7.

1040 Report Minor Deviations

Minor deviations may be undertaken by the person who submitted the plan without submission of an amendment to the plan and shall be reported immediately in writing to the Director.

Actions described in 14 CCR 895.1 which are normally presumed to be substantial deviations may, in a given instance, be minor deviations. Actions listed as substantial deviations in 14 CCR 895.1 but considered to be minor by the submitter, may be undertaken only if the person who submitted the plan submits the proposed deviation in writing to the Director for review and receives approval. Approval shall be given if the Director determines that the proposed minor deviation conforms to the standards provided in 14 CCR 895.1. The Director shall have five (5) working days to act on the application. If the Director or the Director's representative does not act within five (5) working days of receipt of such a deviation, timber operations may commence pursuant to such amendment.

1041 Limitations

A plan shall be limited to an area with reasonably similar timber, geology, soil, topography, climate, and stream characteristics that would constitute a logical harvesting unit. A plan should be limited to that area on which timber operations normally will be completed in one 12-month period, but in no case shall it extend beyond 36 months after the plan is determined to be in conformance or otherwise becomes effective under PRC 4582.7. Plans shall be limited to lands within a particular forest district.

1042 Change of Ownership

Any change in ownership of land or timber must be reported to the Director if such a change occurs after a plan is filed but before a report of satisfactory completion of stocking is issued by the Director. It shall be the responsibility of the timber owner and/or timberland owner listed in the plan to notify the Director of the change of either ownership. Also, before the passage of title, it shall be the responsibility of the seller to notify the purchaser of either the timber or timberland of their responsibility for compliance with the stocking standards of the Act and the rules of the Board.

After a plan is found in conformance with the rules and regulations of the Board, the Director may file a Notice of Stocking Requirements on the property with the recorder of the county within which the plan is located. When a report of satisfactory stocking is issued by the Director, a Notice of Compliance will be sent to the timberland owner.

1043 Cancellation of Plans

All parties, who submitted plan or their successors, must sign the request to the Director for cancellation of a plan. Once cutting has commenced, the plan may not be canceled except as to lands not harvested.

1045 Director Delegation

In order to expeditiously process plans, the Director may make such delegations deemed to be fit to employees of the Department, qualified as RPFs pursuant to Article 3 of Chapter 2.5 of Division 1 of the PRC (commencing with Sec. 750).

1050 Erosion Control Maintenance

(a) Where necessary to minimize soil erosion or slope instability or to prevent degradation of the quality and beneficial uses of water, the department may require that erosion controls be maintained prior to the beginning of a winter period and prior to filing of a work completion report.

CALIFORNIA FOREST PRACTICE RULES

(b) The Director may deem completion report as described in PRC 4585 to have been filed upon the date of receipt if the Department finds that all erosion controls have been constructed and maintained in compliance with the Forest Practice Rules upon the first inspection after receipt of the completion report. Otherwise, the Director shall accept a work completion report for filing only after the Department finds that all erosion controls have been constructed in compliance with the Forest Practice Rules.

(c) The LTO is responsible for proper construction, inspection and maintenance of erosion control during the prescribed maintenance period until the work completion report as described in PRC 4585 is approved by the Director. The landowner is responsible for inspection and any needed repair and maintenance of erosion controls during the remainder of the prescribed maintenance period. Responsibility for erosion control maintenance may be assumed at an earlier date by the landowner or can be delegated to a third party, provided that the assuming party acknowledges such responsibility in writing to the Director.

(d) Upon approving a work completion report, the Director may prescribe a maintenance period which extends for as much as three years after filing the work completion report based on physical evidence (such as location of erosion controls in disturbed areas with high or extreme erosion hazard, on steep or unstable slopes, or within or adjacent to the standard width of a water course or lake protection zone) that erosion controls need to be maintained for the extended maintenance period in order to minimize soil erosion or slope instability or to prevent degradation of the quality and beneficial uses of water.

(e) After approving the work completion report, the Director may extend the prescribed maintenance period for as much as three years after filing of the work completion report if subsequent inspections by the department during the prescribed maintenance period show that erosion controls have failed or are likely to fail to minimize soil erosion or slope instability or to prevent degradation of the quality and beneficial uses of water.

1051 Modified THP

(a) On an ownership of 100 acres or less of timberland, a modified timber harvest plan may be filed by a plan submitter, providing that the following conditions and mitigations are met:

(1) No more than 70% of any existing tree canopy layer is to be harvested on parcels 40 acres or less, and not more than 50% on parcels 41-100 acres. The canopy retained shall be well distributed over the harvest area. Not more than 10% of the THP area shall be harvested under the rehabilitation method. A sample area must be marked before submission of the THP. The sample area shall include at least 10% of the area which is representative of the range of conditions present in the area.

(2) Clearcutting and shelterwood removal, as defined in 14 CCR 913.1(a) [933.1(a), and 953.1(a)] shall not be used, except for legally deeded rights-of-way or easements for utility purposes which are documented in the plan by the RPF by reference to specific deeds or surveys.

(3) Stocking standards, specific to the silvicultural method selected, must be met immediately after harvesting operations are completed.

(4) No heavy equipment operations on slopes greater than 50%, or on areas with high or extreme erosion hazard ratings.

(5) No construction of new skid trails on slopes over 40%.

(6) No timber operations in Special Treatment Areas except log hauling on existing roads not requiring reconstruction.

(7) No timber operations on slides or unstable areas.

(8) New road construction is confined to 600 feet and a 1,000 foot limit total of road construction and reconstruction combined.

(9) No heavy equipment operations within a watercourse or lake protection zone, meadows, or wet areas, except for maintenance of existing roads, drainage facilities or structures.

(10) No listed species will be directly or indirectly adversely impacted by proposed timber operations. For timber operations which potentially could adversely affect a listed species or the habitat of the species, the consultation process with DFG pursuant to F&GC 2090 or 2081 shall be completed before the THP is approved.

(11) Timber harvesting is only allowed in the WLPZ if: 1) sanitation-salvage harvesting is the only silvicultural system to be used in the WLPZ and it must be in compliance with 14 CCR 916.4(b) [936.4(b), 956.4(b)]; or 2) if harvesting removes no more than 30% of any existing canopy layer. Harvesting under 2) above shall not occur again in the WLPZ for a 10-year period following completion of the THP.

CALIFORNIA FOREST PRACTICE RULES

(12) No timber operations within potentially significant archaeological sites.

(13) No alternatives, exceptions, or in-lieu practices allowed for watercourse or lake protection measures, standard road and landing widths, or erosion control measures, except for use of existing roads within WLPZ after compliance with examination, evaluation, and mitigation(s) per 14 CCR 916.4(a) [936.4(a), 956.4(a)].

(14) Winter timber operations except as conditioned by the Director to avoid potential significant cumulative impacts shall be in accordance with 14 CCR 914.7 (a) and (b) [934.7 (a) and (b), 954.7(a) and (b)].

(15) Harvesting will not reduce the amount of timberland occupied by late succession forest stands currently greater than or equal to 5 acres in size.

(16) In addition to (1)-(15) all other rules of the Board shall apply to operations specified in this section.

1051.1 Contents of Modified THP

A plan submitted under section 1051 above shall contain all the provisions of 14 CCR 1034 except the following: (o), (x)(7), (z), (cc), (dd), (ee), and the RPF shall:

(a) Identify and map those areas currently understocked and not to be harvested that are at least three acres in size.

(b) Use a topographic map base with a minimum scale of 1:12,000.

(c) Certify in the THP that the conditions or facts stated in items 1-16 above exist on the THP area at the time of submission, and that the preparation, mitigation, and analysis of the THP and no identified potential significant effects remain undisclosed.

(d) Certify that a meeting will be held at the THP site before timber operations commence with the RPF responsible for the plan or supervised designee and the licensed timber operator who will be operating on the THP where the contents and implementation of the plan have been reviewed and discussed. Operations pursuant to this section shall use an alternative to the cumulative impacts assessment specified in 14 CCR 898, 912.9 [932.9, 952.9], and Technical Rule Addendum No.2. Operations conducted according to this section are presumed to be unlikely to cause a significant adverse impact to the environment due to the specific restrictive mitigations required in (1)-(15) above.

This presumption of unlikely impacts shall not apply to THPs for which: 1) the Director determines it does not meet the criteria of subsection (a), or 2) the Director determines in consultation with trustee or responsible agencies, or upon review of public comments that a fair argument exists that significant individual or cumulative impacts will result from timber operations. Where issues (a fair argument) are raised the RPF shall complete the appropriate portion of Technical Rule Addendum No. 2 and submit that information for the Director's review.

1051.2 Review of Modified THP

The Director shall require a preharvest inspection of modified timber harvest plans when substantial question by Review Team members exist on plan contents or environmental impacts, and where winter operations are proposed according to 914.7 (a) and (b) [934.7(a) and (b), 954.7 (a) and (b)].

1052 Emergency Notice

(a) Before cutting or removing timber on an emergency basis, an RPF on behalf of a timber owner or operator shall submit a Notice of Emergency Timber Operations to the Director, on form RM-67 (9/99) as prescribed by the Director. The notice shall include, but not be limited to, the following:

(1) Names and addresses of all timberland owner(s), timber owner(s), and timber operator(s) for the area on which timber will be cut or removed.

(2) A description of the specific conditions that constitute the emergency, its cause, extent and reason for immediate commencement of timber operations.

(3) Legal description of the area from which timber will be cut or removed.

(4) A titled USGS (if available) or equivalent topographic map(s) of scale not less than 2" to the mile, or larger scale, showing the area from which timber will be cut or removed, the legal description, roads and Class I, II, III and IV watercourses, and yarding systems if more than one will be used.

(5) Yarding system to be used.

CALIFORNIA FOREST PRACTICE RULES

(6) The expected dates of commencement and completion of timber operations.

(7) A declaration by the RPF, made under penalty of perjury, that a bona fide emergency exists which requires emergency timber operations.

(8) A declaration by the timber owner, made under penalty of perjury, that any applicable timber yield taxes will be paid pursuant to Section 38115 of the Revenue and Taxation Code.

(9) Name, address, license number, and signature of the RPF who prepares the notice and submits it to the Director on behalf of the timber owner or operator.

(10) For Emergency Notices covering three acres or more in size, a Confidential Archaeological Letter that includes all information required by Section 929.1 [949.1,969.1] (b)(2), (6), (7), (8) and (10), including site records, if required pursuant to 929.1[949.1, 969.1](f). This Confidential Archaeological Letter shall be included with the submittal of the Emergency Notice to the Director. The RPF or supervised designee shall also submit a complete copy of the Confidential Archaeological Letter and two copies of any required archaeological or historical site records, to the appropriate Information Center of the California Historical Resource Information System within 30 days from the date of Emergency Notice submittal to the Director.

(b) Timber operations pursuant to an emergency notice shall comply with the rules and regulations of the Board. A person conducting timber operations under an Emergency Notice shall comply with all operational provisions of the Forest Practice Act and District Forest Practice Rules applicable to "Timber Harvest Plan", "THP", and "plan".

(c) In-lieu practices for watercourse and lake protection zones as specified under Article 6 of the rules, exceptions to rules, and alternative practices are not allowed unless necessary to protect public health and safety.

(d) Timber operations pursuant to an Emergency Notice may not commence for five working days from the date of the Director's receipt of the Emergency Notice unless such waiting period is waived by the Director. The Director shall determine whether the emergency notice is complete. If it is found to be complete the Director shall send a copy of a notice of acceptance to the timberland owner. If the Emergency Notice is not complete it shall be returned to the submitter. If the Director does not act within five working days of receipt of the Emergency Notice, timber operations may commence.

(e) Timber operations shall not continue beyond 120 days after the Emergency Notice is accepted by the Director unless a plan is submitted to the Director and found to be in conformance with the rules and regulations of the Board.

1052.1 Emergency Conditions

The following are conditions that constitute an emergency pursuant to 14 CCR 895.1:

(a) Trees that are dead or dying as a result of insects, disease, parasites, or animal damage.

(b) Trees that are fallen, damaged, dead or dying as a result of wind, snow, freezing weather, fire, flood, landslide or earthquake.

(c) Trees that are dead or dying as a result of air or water pollution.

(d) Cutting or removing trees required for emergency construction or repair of roads.

The following are conditions that constitute a financial emergency as defined in 14 CCR 895.1:

Potential financial loss of timber previously inoperable or unmerchantable due to one or more of the following factors: access, location, condition, or timber volume that has unexpectedly become feasible to harvest provided that the harvest opportunity will not be economically feasible for more than 120 days and provided that such operations meet the conditions specified in 1038(b)(1)-(10) and meet minimum stocking requirements at the completion of timber operations.

1052.2 Emergency Substantiated by RPF

The RPF preparing the Notice of Emergency Timber Operations shall describe the nature of the emergency and the need for immediate cutting in sufficient detail so that the reason for the emergency is clear. Where tree killing insects have killed and are likely to kill trees within one year on timberland an emergency is presumed to exist. Trees will be considered likely to die when they are determined, by an RPF, to be high risk by either:

(a) Risk classification systems including Smith et al., 1981; *The California Pine Risk-Rating System: Its Development, Use, and Relationship to Other Systems; In Hazard-Rating Systems in Forest Insect Pest*

CALIFORNIA FOREST PRACTICE RULES

Management, Hedden et al, eds. USDA Forest Service General Technical Report WO - 27, pp. 53-69; Ferrell. 1989; *Ten-Year Risk-Rating Systems for California Red Fir and White Fir: Development and Use*; USDA Forest Service General Technical Report PSW-115, 12p.; or similar risk-rating systems recognized by the profession; or

(b) Where evidence of a current beetle attack exists (i.e., existence of boring dust, woodpecker feeding, or recent top kill) and these trees are within 100 feet of multiple tree kills. Such trees shall be marked by an RPF or the supervised designee before felling.

1052.3 Emergency Notice For Insect Damaged Timberlands

Emergency timber operations, under the presumed emergency standard of 14 CCR 1052.2, may be commenced provided an RPF is responsible for an on-site inspection, and tree marking when required by subsection (a):

(a) The emergency notice used with this section is to be used only for the harvesting of dead trees and those dying because of insect attack. Trees with green crowns that are to be harvested must be under insect attack which is likely to lead to mortality within one year, and shall be stump marked or otherwise designated by an RPF prior to cutting.

(b) A 60-day extension of an existing emergency notice may be submitted by a RPF where expanded or subsequent insect attack is occurring and it is explained and justified why the timber operation could not be completed during the first 60-day period. [NOTE: Section 1052.3 (b) was made invalid by changes operative 1-1-98, Register 97, Number 48, to Section 1052.]

Article 3 Timber Harvesting Plan Appeal Procedures

1053 Purpose of Regulations

The regulations contained in this article govern procedures affecting appeals to the Board on return of plans by the Director pursuant to the provisions of PRC 4582.7.

1054 Return of Plan by Director

(a) When the Director determines that a plan is not in conformance with the rules of the Board, the plan shall be returned to the person submitting the plan with a statement including the following:

- (1) The reasons for returning the plan;
- (2) Notice that the person submitting the plan has a right to a public hearing before the Board, providing the person submitting the plan requests such hearing within 10 days from receipt of such plan as set forth in 14 CCR [1054.1]; and
- (3) Notice that timber operations under the plan shall not commence.

(b) The plan and said statement shall be delivered as follows:

- (1) By personal service upon the person submitting the plan; or
- (2) By registered or certified mail, return receipt requested, to the person submitting the plan at last address of record.

1054.1 Right to Request Public Hearing

Any person submitting a plan to whom such plan is returned by the Director on the grounds that it is not in conformance with the rules of the Board, may within ten days of receipt of the plan request a public hearing before the Board consistent with Sections [1054.2 and 1054.3].

1054.2 Form of Request for Hearing

The request for hearing shall be in writing and shall contain the following:

- (a) A statement requesting a hearing before the Board;
- (b) Identification of the plan; and
- (c) The name and address of the person making the request.

1054.3 Filing of Request for Hearing

Such request shall be deemed to be filed on the date, whichever is earlier, upon which it is postmarked or the date upon which it is otherwise received at the of the of the State Board of Forestry [and Fire Protection]

CALIFORNIA FOREST PRACTICE RULES

at 1416 Ninth Street, Room 1506-14, [P.O. Box 944246,] Sacramento, CA [94244-2460].

1054.4 Public Hearing

The Board shall schedule and hold a public hearing on such request no later than 30 days from the filing of the request for hearing, or at such later time as may be mutually agreed upon by the Board and the person submitting the plan and filing the request. The hearing may be scheduled as part of a regular meeting of the Board, or as part of any special meeting, provided that sufficient time is provided for the notice of hearing in accordance with 14 CCR 1056.2.

1054.5 Notice of Hearing

(a) At least 15 days prior to said hearing, public notice thereof shall be given as follows:

- (1) Mailing such notice to the applicant, and mailing such notice to the Director for distribution as provided in subsections (2)-(5) below;
- (2) Mailing such notice to any person who has submitted written comment on the plan or to any person requesting notice of the appeal or hearing;
- (3) Posting such notice in a conspicuous location available to the public in the appropriate regional office of the Department;
- (4) Posting of such notice at the place where public notices are customarily posted at the county courthouse of the county within which the proposed timber operations are to take place;
- (5) Any other dissemination of the notice determined to be appropriate by the Director to provide full participation in the hearing by the interested public.

(b) The notice of hearing shall include the following:

- (1) The name of the person submitting the plan;
- (2) Identification of the plan, including the number of the plan, a brief description of the location of the timber operations referred to in the plan by reference to any commonly known landmarks in the area, and a brief description of the proposed timber operations;
- (3) A statement that the plan has been returned to the person submitting the plan because the Director has determined that the plan is not in conformance with the rules of the Board, and that the person submitting the plan has requested a public hearing before the Board pursuant to PRC 4582.7. In addition, a statement inviting the person submitting the plan and the public to make statements at the hearing regarding the plan; and
- (4) The time, date, and location of the public hearing.

1054.6 Hearing Record

The record before the Board upon the public hearing shall be as follows:

- (a) The timber harvesting plan;
- (b) All reports, findings, communications, correspondence, and statements in the file of the Department relating to the plan.

1054.7 Hearing Procedures

- (a) The public hearing should normally proceed in the following manner:
 - (1) Identification of the record;
 - (2) Statements on behalf of person submitting the plan;
 - (3) Statements by member of the public;
 - (4) Motion to close public hearing.
- (b) Notwithstanding the above, the chairperson may, in the exercise of discretion, determine the order of the proceedings.
- (c) The chairperson may impose reasonable time limits upon statements and presentations and may accept written statements in lieu of oral statements.
- (d) The public hearing shall be recorded either electronically or by other convenient means.

1054.8 Order of the Board

Following the public hearing, the Board shall determine whether, upon the record before it, the plan is in conformance with the rules and regulations of the Board and the provisions of the Act. If the Board

CALIFORNIA FOREST PRACTICE RULES

determines that the plan is in conformance with the rules and regulations of the Board and the provisions of the Act, it shall make its order approving the plan. If the Board determines that the plan is not in conformance with the regulations of the Board and the provisions of the Act, it shall make its order disapproving the plan. Approval of the plan by the Board constitutes authorization that timber operations may commence and be conducted in accordance with the plan as approved and in accordance with the rules and regulations of the Board and the provisions of the Act. Timber operations shall not take place where the Board disapproves the plan. Disapproval of a plan shall be without prejudice to the applicant submitting a plan at any later time complying with the rules and regulations of the Board and the provisions of the Act. Where the Board approves the plan, notice thereof shall be filed with the Secretary of Resources, and within 10 working days such notice shall be transmitted to the agencies and persons referred to in 14 CCR 1037.3, and for posting at the places referred to in Section 1037.1. The order of approval shall include written response to significant environmental points raised during the evaluation process.

1055 County Appeals Procedures

The Board of Supervisors of a county for which rules and regulations have been adopted pursuant to PRC 4516.5 may appeal the Director's approval of a THP by doing the following:

(a) No later than ten days from the date of approval, the county shall file with the Executive Officer of the Board of Forestry [*and Fire Protection*] and mail to the plan submitter a statement containing:

- (1) The name of the submitter of the Timber Harvesting Plan;
- (2) The number of the Timber Harvesting Plan;
- (3) The location of the proposed timber operations;
- (4) A concise summary of all facts upon which the appeal is based;
- (5) A copy of or reference to all documents which support the appellant's position;
- (6) The name and phone number of the county staff member who will be the primary contact for purposes of the appeal;
- (7) A copy of the authorization by the Board of Supervisors or its authorized designee for the appeal and containing the specific finding that the public health and safety, or the environment is threatened by the approval of the Timber Harvesting Plan and what form that threat takes;
- (8) Certification that the county participated in the initial inspection of the plan area with the Director and participated in a multidisciplinary review of the plan.

(b) The county shall promptly telephone the Director and the plan submitter to inform them of the filing of the appeal.

1055.1 Hearing on County Appeal

The Board shall grant to a county that meets the requirements for filing an appeal an initial hearing to consider the county's request for an appeal at the next regularly scheduled Board meeting following the receipt of the request. The Board shall grant a hearing on an appeal by a county pursuant to PRC 4516.6 if the Board finds that the appeal raises substantial issues with respect to public health and safety or to the environment. If the Board finds that the appeal raises no substantial issues with respect to public health and safety or to the environment, the Board shall refuse to grant a hearing on an appeal. In making this determination, the Board shall consider the following:

- (a) Whether the appeal raises environmental issues which can be addressed by the Board within the limits of the PRC and the rules of the Board; and
- (b) Whether the appeal raises public health and safety issues which involve threats to the lives, health, or property of county residents.

1055.2 County Appeal Hearing Procedures-Scheduling

The Board shall schedule and hold a public hearing on an appeal by a county no later than 30 days from the filing of the written statement of appeal, or at such later time as may be mutually agreed upon by the Board, the county, and the plan submitter. The hearing maybe scheduled as part of a regular meeting of the Board or may be conducted by a committee of the Board as provided in PRC 4516.6(d). Sufficient time must be provided for the notice of hearing in accordance with 14 CCR [1055.3].

1055.3 County Appeal Hearing Procedures-Notice

CALIFORNIA FOREST PRACTICE RULES

- (a) At least 15 days prior to the hearing, the Board shall give public notice as follows:
- (1) Mailing the notice to the county and the plan submitter and sending the notice to the Director for distribution as provided in subsection (2)-(5) below;
 - (2) Mailing the notice to any person who has submitted written comment on the plan and to any person who requests notice of the appeal or hearing;
 - (3) Posting of the notice in a conspicuous location available to the public in the appropriate regional office of the Department;
 - (4) Posting of the notice at the place where notices are customarily posted at the county courthouse of the county within which the proposed timber operations are to take place;
 - (5) Any other dissemination of the notice determined to be appropriate by the Director to provide full participation in the hearing by the interested public.
- (b) The notice of hearing shall include the following:
- (1) The name of the Person submitting the plan;
 - (2) Identification of the plan, including the number of the plan, a brief description of the location of the timber operations referred to in the plan by reference to any commonly known landmarks in the area, and a brief description of the proposed timber operations;
 - (3) A statement that the county has appealed the Director's decision to approve the plan and has requested a public hearing pursuant to PRC 4516.6. The notice shall also include a statement inviting the person submitting the plan and the public to make statements at the hearing regarding the plan; and
 - (4) The time, date, and location of the public hearing.

1055.4 County Appeal Hearing Procedures-Record

The record before the Board upon the public hearing shall be as follows:

- (a) The timber harvesting plan;
- (b) All reports, findings, communications, correspondence and statements in the file of the Department relating to the plan.

1055.5 County Appeal Hearing Procedures-Sequence

- (a) The public hearing should normally proceed in the following manner:
 - (1) Identification of the record;
 - (2) Statements on behalf of the county;
 - (3) Statements on behalf of person submitting the plan;
 - (4) Statements of members of the public;
 - (5) Motion to close public hearing.
- (b) Notwithstanding the above, the chairperson may in the exercise of discretion, determine the order of the proceedings.
- (c) The chairperson may impose reasonable time limits upon statements and presentations and may accept written statements in lieu of oral statements.
- (d) The public hearing shall be recorded either electronically or by other convenient means.

1055.6 County Appeal Hearing Procedure-Order

Following the public hearing, the Board shall determine whether, upon the record before it, the plan is in conformance with the rules and regulations of the Board and the provisions of the Act. If the Board determines that the plan is in conformance with the rules and regulations of the Board and the provisions of the Act, it shall make its order approving the plan. If the Board determines that the plan is not in conformance with the regulations of the Board and the provisions of the Act, it shall make its order disapproving the plan. Approval of the plan by the Board constitutes authorization that timber operations may commence and be conducted in accordance with the plan as approved and in accordance with rules and regulations of the Board and the provisions of the Act. Timber operations shall not take place where the Board disapproves the plan. Disapproval of a plan shall be without prejudice to the applicant submitting a plan at any later time complying with the rules and regulations of the Board and the provisions of the Act. Where the Board approves the plan, notice thereof shall be filed with the Secretary of Resources, and within ten working days such notice shall be transmitted to the agencies and persons referred to in 14 CCR 1037.3, and for posting at the places referred to in Section 1037.1. The order of approval shall include written

CALIFORNIA FOREST PRACTICE RULES

response to significant points raised in the appeal.

1056 Head of Agency Appeals Procedure

The State Water Resources Control Board (SWRCB) or the Director of the Department of Fish and Game (DFG) pursuant to PRC 4582.9 may appeal the Director's approval of a THP, or Substantial Deviation (14 CCR 1036 and 1039) by doing the following:

(a) No later than ten days from the date of THP approval, the SWRCB and DFG shall file with the Executive Officer of the Board of Forestry [*and Fire Protection*] and mail to the plan submitter and Director of CDF a statement containing:

- (1) The name of the submitter of the THP;
 - (2) The number of the THP assigned by CDF;
 - (3) The location of the proposed timber operations as described in the Notice of Intent;
 - (4) A concise summary of all facts upon which the appeal is based;
 - (5) A copy of or reference to all documents within the official THP record which support the appellant's position;
 - (6) The name and phone number of the SWRCB designee or DFG staff member who will be the primary contact for purposes of the appeal;
 - (7) A copy of the authorization by the SWRCB or DFG or its authorized designee for the appeal and containing the specific finding that the environment or the public health, safety, or general welfare is threatened by the approval of the THP or Substantial Deviation and what form that threat takes;
 - (8) Certification that the SWRCB or Regional Water Quality Control Board or DFG participated in a multidisciplinary review of the plan including an on site inspection prior to plan approval;
 - (9) A statement that the timber operations are not to proceed until the appeal has been acted on by the Board as stated in PRC Section 4582.9.
 - (10) A copy of regulations pertaining to head-of-agency appeals.
 - (11) A statement to contact the Board for other information about the hearing process.
- (b) The SWRCB or DFG shall promptly telephone the Director and plan submitter to inform them of the filing of the appeal.
- (c) If timber operations have commenced, the Department will notify the timber operator to stop all operations.

1056.1 Hearing on Head of Agency Appeal

The Chairman of the Board of Forestry [*and Fire Protection*] shall, without being required to consult other members of the Board, within five (5) working days of receiving the appeal grant a hearing on an appeal by SWRCB or DFG pursuant to PRC Section 4582.9 if the Chairman finds that the appeal raises substantial issues with respect to the environment or to public safety. If the Chairman finds that the appeal raises no substantial issues with respect to the environment or to public safety, he or she shall refuse to grant a hearing on an appeal. The Chairman will inform the appealing agency, the plan submitter, and the Department of his or her decision. In making this determination, the Chairman shall consider the following:

- (a) Whether the appeal raises environmental issues which can be addressed by the Board within the limits of the Public Resources Code and the rules of the Board and other applicable laws; and
- (b) Whether the appeal raises public safety issues which involve threats to the lives, health, or property of state residents.

1056.2 Head of Agency Appeal Hearing Procedures-Scheduling

The Board shall schedule and hold a public hearing on an appeal by SWRCB or DFG no later than 30 days from the filing of the written statement of appeal, or at such later time as may be mutually agreed upon by the Board, the appellant(s), and the plan submitter. The hearing may be scheduled as part of a regular meeting of the Board or may be conducted by a committee of the Board as provided in PRC 4582.9 (d). Sufficient time must be provided for the notice of hearing in accordance with 14 CCR 1056.3.

1056.3 Head of Agency Appeal Procedures-Notice

- (a) At least 15 days prior to the hearing, the Board shall give public notice as follows:
 - (1) Mailing the notice to the SWRCB designee or DFG, and the plan submitter and sending the

CALIFORNIA FOREST PRACTICE RULES

notice to the Director for distribution as provided in subsection (2)-(5) below;

- (2) Mailing the notice to any person who has submitted written comment on the plan and to any person who requests notice of the appeal or hearing;
 - (3) Posting of the notice in a conspicuous location available to the public in the appropriate regional office and ranger unit headquarters of the Department;
 - (4) Posting of the notice at the place where notices are customarily posted at the county courthouse of the county within which the proposed timber operations are to take place;
 - (5) Any other dissemination of the notice determined to be appropriate by the Director to provide participation in the hearing by the interested public.
- (b) The notice of hearing shall include the following:
- (1) The name of the person submitting the plan;
 - (2) Identification of the plan, including the CDF administration number of the plan, a brief description of the location of the timber operations referred to in the plan by reference to any commonly known landmarks in the area, and a brief description of the proposed timber operations;
 - (3) A statement that the SWRCB or DFG has appealed the Director's decision to approve the plan. A statement that the Board has granted a public hearing pursuant to PRC 4582.9. The notice shall also include a statement inviting the person submitting the plan and the public to make statements at the hearing regarding the basis of the appeal on the plan; and
 - (4) The time, date, and location of the public hearing.

1056.4 Head of Agency Appeal Hearing Procedures-Record

The record before the Board upon completion of the public hearing shall be as follows:

- (a) The THP, or Substantial Deviation.
- (b) All reports, findings, communications, correspondence and statements in the file of the Department relating to the plan at the time of approval.
- (c) Arguments from the appealing agency, plan submitter, and the public related to the material in the record.

1056.5 Head of Agency Appeal Hearing Procedures-Sequence

- (a) The public hearing should normally proceed in the following manner:
 - (1) Identification of the record by CDF;
 - (2) Statements on behalf of the appealing agency;
 - (3) Statements on behalf of person submitting the plan;
 - (4) Statements of members of the public, including other interested agencies;
 - (5) Response on behalf of CDF "Chairman or designee";
 - (6) Motion to close public hearing;
- (b) Notwithstanding the above, the chairman or designee may in the exercise of discretion, determine the order of the proceedings.
- (c) The chairperson may impose reasonable time limits upon statements and presentations and may accept written statements in lieu of oral statements.
- (d) The public hearing shall be recorded either electronically or by other convenient means.

1056.6 Head of Agency Appeal Hearing Procedures-Order

The Board has ten days following the public hearing to determine whether, upon the record before it, the plan is in conformance with the rules and regulations of the Board, the provisions of the Act and all other applicable provisions of law, including the Timberland Productivity Act. If the Board determines that the plan is in conformance with the rules and regulations of the Board, the provisions of the Act and other applicable laws, it shall make its order approving the plan within ten days of conclusion of the hearing. If the Board determines that the plan is not in conformance with the regulations of the Board, the provisions of the Act, and other applicable laws, it shall make its order disapproving the plan within 10 days of conclusion of the hearing. Approval of the plan by the Board constitutes authorization that timber operations may commence upon filing of the order of approval with the Secretary of Resources. Operations shall be conducted in accordance with the plan as approved by CDF and in accordance with the rules and regulations of the Board and the provisions of the Act, and other applicable laws. Timber operations shall not take place

CALIFORNIA FOREST PRACTICE RULES

where the Board disapproves the plan. Disapproval of a plan shall be without prejudice to the applicant submitting a plan at any later time complying with the rules and regulations of the Board and the provisions of the Act. The Board may set forth in the order of disapproval the conditions under which it believes the plan would have been approved. Where the Board approves the plan, the order there of shall be filed with the Secretary of Resources within ten working days of decision, such order of approval shall be transmitted to the plan submitter, CDF, and the appealing agency(ies), and for posting at the places referred to in Section 1056.3. Their order of approval shall include written response to significant points raised in the appeal.

Article 3.2 Administrative Penalty Hearing Procedures

1057 Purpose of Regulations

The regulations contained in this article govern procedures for request(s) for hearing(s) to the Board of Forestry and Fire Protection pursuant to Public Resources Code (PRC) §4601.2 concerning issuance of an administrative penalty by the Director of the Department of Forestry and Fire Protection.

1057.1 Filing of Petition and Notice of Defense/Request for Hearing

Any person filing a petition to the Board pursuant to PRC §4601.2 concerning the issuance of an administrative penalty by the Director shall, within ten (10) days of service of the complaint and proposed order setting an administrative penalty, file a Notice of Defense/Request for Hearing with the Board requesting a hearing. The Notice of Defense/Request for Hearing shall be on the form set forth in Section 1057.5 of this article and shall supply the following information to the Board:

(a) Written statements, with supporting documentation, indicating specifically the basis for the petitioner's challenge of the Director's complaint and proposed order of administrative penalty;

(b) A written statement advising the Board of the name, address and telephone number of the petitioner's representative, if any.

1057.2 Failure to Request Hearing

If the petitioner fails to file a Notice of Defense/Request for Hearing within the time period referenced in Section 1057.1 of this article, the Board shall adopt the Director's Complaint and Proposed Order without hearing.

1057.3 Hearing Procedures

A hearing shall be conducted within 180 days of the date on which the petitioner was served with the complaint and proposed order provided a timely request for a hearing has been received. The Chairperson of the Board may delegate the conduct of the hearing to a committee of the Board, which shall be composed of at least three (3) members of the Board, or elect to utilize an Administrative Law Judge assigned in accordance with Government Code §11370.3. If the Chairperson delegates the matter to a committee of the Board, a majority of the committee members shall not have a financial interest in the forest products or range industry. The committee may exercise any power the Board may exercise in any action under this article.

If the matter is heard before the full Board or a committee of the Board, the Chairperson may elect to use an Administrative Law Judge or a representative from the Office of the Attorney General to preside over the hearing.

If the matter is to be assigned to an Administrative Law Judge, the Chairperson shall indicate if the Administrative Law Judge is to provide a Proposed Decision for review by the Board, or, in the alternative, if the Decision of the Administrative Law Judge is final. In the event that the matter is delegated to an Administrative Law Judge, the proceedings shall be conducted in accordance with the provisions of Chapter 5 (commencing with §11500) of Part 1, Division 3, Title 2 of the Government Code.

1057.4 Administrative Record

The Administrative Record shall consist of the following:

(a) the record developed and evidence submitted during the hearing before an Administrative Law Judge, including but not limited to the Proposed Decision and Findings of Fact, when the hearing was conducted before an Administrative Law Judge; or,

(b) the Complaint and Proposed Order from the Director, evidence submitted by the Director, evidence

CALIFORNIA FOREST PRACTICE RULES

submitted on behalf of the petitioner, any other relevant evidence which, in the judgement of the Board, should be considered applicable, and testimony presented during the hearing on the petition if the hearing is conducted before the Board.

1057.5 Petition and Notice of Defense/Request for Hearing Form

BEFORE THE
BOARD OF FORESTRY AND FIRE PROTECTION
FOR THE STATE OF CALIFORNIA

In the Matter of:

CDF Docket No.:

RESPONDENT.

NOTICE OF DEFENSE;

REQUEST FOR HEARING

I, the undersigned and respondent named in this proceeding, hereby acknowledge receipt of a copy of the Complaint and Proposed Order against me.

I hereby request a hearing in this proceeding to permit me to present my defense to the allegations contained in the Statement of Issues.

Dated: _____ Signed _____

(or attorney for respondent)

CALIFORNIA FOREST PRACTICE RULES

1058 Hearing Procedures-Notice

If the Board or committee of the Board holds a hearing on the matter, the following shall apply:

- (a) At least twenty (20) days prior to the hearing, the Board shall give public notice as follows:
 - (1) Mailing or delivering by personal service the notice to the petitioner;
 - (2) Mailing or delivering by personal service the notice to the Director;
 - (3) Mailing the notice to any person who requests notice of the petition or hearing; and
 - (4) Mailing the notice to the Board's regular mailing list.
- (b) The Notice of the hearing shall include:
 - (1) The name of the petitioner;
 - (2) A statement describing the basis for the action;
 - (3) The amount of the administrative penalty petitioned; and
 - (4) The date, time, and location of the hearing.

1058.1 Hearing Procedures-Recording and Transcription

Hearings conducted under the procedures of this article shall be electronically recorded by the Board. Cost of transcription or reproduction of the electronic recording, if requested shall be borne by the party making such request.

1058.2 Hearing Procedures-Use of Board Hearing Procedure and Sequence

(a) The Board shall conduct the petition hearing under this article in accordance with the provisions of Chapter 5 (commencing with §11500) of Part 1, Division 3, Title 2 of the Government Code. The hearing procedure is intended to satisfy due process and public policy requirements in a manner that is simpler and more expeditious than hearing procedures otherwise required by statute.

- (b) The hearing shall normally proceed in the following manner:
 - (1) Identification of any written material submitted to the Board prior to the hearing;
 - (2) Statements on behalf of the petitioner and submission of evidence;
 - (3) Cross Examination of petitioner's statements;
 - (4) Statements on behalf of the Director and submission of evidence;
 - (5) Cross Examination of Director's statements;
 - (6) Rebuttal on behalf of the petitioner;
 - (7) Rebuttal on behalf of the Director;
 - (8) Closing statements on behalf of petitioner and Director;
 - (9) Motion to close the hearing.

(c) Notwithstanding the above, the Chairperson or the Chairperson's designee (Board member) for the purposes of conducting the hearing may, in the exercise of discretion, determine the order of the proceedings.

(d) The Chairperson or the Chairperson's designee (Board member) shall have the authority to impose reasonable and equitable time limits upon statements and presentations and to accept written statements in lieu of oral statements. Any written statements shall be submitted to the Board at least ten days prior to the hearing.

1058.3 Hearing Procedures-Determination

(a) Following the hearing, the Board shall determine:

- (1) Whether the alleged violations cited in the Director's Proposed Order are supported by substantial evidence in light of the whole record (as defined in section 1057.4) before it; and
- (2) Whether to affirm, modify, or set aside, in whole or in part, the administrative penalty issued by the Director.

(b) The Board shall issue its own written order upholding its determination within forty-five (45) days of the close of the hearing.

(c) Notification of the Board's determination shall be made by certified mail or personal service to the petitioner and the Director within fifteen (15) days following the regular business meeting of the Board at which the decision is made.

CALIFORNIA FOREST PRACTICE RULES

1058.4 Review of Proposed Decision and Findings of Fact

If the Board Chairperson has assigned the hearing to an Administrative Law Judge and requested a Proposed Decision and Findings of Fact, the Board shall set on their agenda a review and discussion of the Proposed Decision and Findings of Fact at its next regularly scheduled meeting, where a quorum is present, following the receipt of the Proposed Decision and Findings of Fact from the Office of Administrative Hearings. Public notice of the agenda item shall be provided to those persons listed in section 1058 not less than ten (10) days prior to the Board meeting.

1058.5 Determination

The adoption, rejection or modification of the Proposed Decision, including the various procedural requirements and notifications, shall follow the process set forth in Chapter 5 (commencing with section 11500) of Part 1, Division 3, Title 2 of the Government Code, except that the Board shall make a written determination within forty-five (45) days of the date the Board first considered the proposed decision.

1059 Infractions

(a) Pursuant to PRC 4601.4(b), these rules are procedural in nature, the violation of which does not result in or cause environmental damage. The rule list consists of 14 CCR Sections 915.4, 935.4, 955.4; 918.1, 938.1, 958.1; 924.1; 925.2; 925.4; 926.2; 926.3; 926.23; 927.2; 927.14; 928.2; 929.1, 949.1, 969.1; 1029; 1032.7; 1032.10; 1034; 1035.2; 1035.3(d); 1038.2; 1042; 1051.1; 1052(a); 1075; 1080.4; 1090.2; 1090.5; 1090.7; 1090.11; 1090.12(c); 1090.13; 1090.26; 1091.4; 1092.04(d); 1092.07; 1092.09; 1092.13; 1092.14(d); 1092.15; 1104.1(a)(1); 1105; 1106.1; 1106.3(a).

(b) Infractions shall not be prosecuted if they are corrected within 10 working days of issuance of notification of the violation. Notification and response must be by certified mail. Date of certification identifies date of notification and response.

CALIFORNIA FOREST PRACTICE RULES

Article 4 Timber Site Classification

1060 Site Classification

The site classification system of productive potential of timberland for administration of the Act and rules thereunder is set forth in the table hereinafter:

SITE CLASS	<i>Young Growth Redwood¹</i>		<i>Douglas Fir²</i>		<i>Ponderosa Pine, Jeffery Pine, Mixed Conifer & True Fir³</i>			
	SITE INDEX ⁴		SITE INDEX ⁴		SITE INDEX ⁴		SITE INDEX ⁵	
	<i>feet@ 100yrs.</i>	<i>meters@ 100yrs.</i>	<i>feet@ 100yrs.</i>	<i>meters@ 100yrs.</i>	<i>feet@ 100yrs.</i>	<i>meters@ 100yrs.</i>	<i>feet@ 300yrs.</i>	<i>meters@ 300yrs.</i>
I	<i>180 or more</i>	<i>54.86 or more</i>	<i>194 or more</i>	<i>59.12 or more</i>	<i>114 or more</i>	<i>35.11 or more</i>	<i>163 or more</i>	<i>49.68 or more</i>
II	<i>155-179</i>	<i>47.24- 54.56</i>	<i>164-193</i>	<i>49.99- 58.83</i>	<i>93-113</i>	<i>28.35- 34.44</i>	<i>138-162</i>	<i>42.06- 49.38</i>
III	<i>130-154</i>	<i>39.62- 46.94</i>	<i>134-163</i>	<i>40.84- 49.68</i>	<i>75-92</i>	<i>22.86- 28.04</i>	<i>113-137</i>	<i>24.44- 41.76</i>
IV	<i>105-129</i>	<i>32.00- 39.32</i>	<i>103-133</i>	<i>31.39- 40.54</i>	<i>60-74</i>	<i>18.29- 22.56</i>	<i>88-112</i>	<i>26.82- 34.14</i>
V	<i>Less than 105</i>	<i>Less than 32.00</i>	<i>Less than 103</i>	<i>Less than 31.39</i>	<i>Less than 60</i>	<i>Less than 18.29</i>	<i>Less than 88</i>	<i>Less than 26.82</i>

¹Lindquist, James L., and Marshall N. Palley. *Empirical Yield Tables for Young-Growth Redwood*, California Agriculture Experiment Station Bulletin. 796, 47pps. 1963 (Site index based on average height of dominant trees at breast height age of 100 years). Use in young growth redwood stands in which more than 20% of the stand by basal area is redwood and when sufficient dominant redwood trees are available to determine site index.

²McArdle, Richard E., and Walter H. Meyer. *The Yield of Douglas Fir in the Pacific Northwest*. USDA Technical Bulletin 201, 74 pps. Rev. 1961. Adjusted to average height of dominant trees after Forest Research Note No. 44, Pacific Northwest Forest and Range Experiment Station, by Forest Survey, Calif. Forest and Range Experiment Station. 1948 (Site index based on average height of dominant trees at age 100 years). Use in young growth redwood stands in which 20% or less of the stand by basal area is redwood or when sufficient dominant redwood trees are not available to determine site index. Use also in old growth redwood stands. In such cases, measure Douglas-fir trees for determining site index. Also use for Sitka spruce, grand fir, hemlock, bishop pine, and Monterey pine stands.

³Dunning, Duncan. *A Site Classification for the Mixed-Conifer Selection Forests of the Sierra Nevada*. USDA Forest Service California Forest and Range Experiment Station, Forest Research Note 28, 21 pps. 1942 (Site index based on average height of dominant trees at age 100 and 300 years). Use also for lodgepole pine stands. For old growth stands use height of dominants at age 300 years.

⁴Average total height in feet and meters of dominant trees at 100 years of age.

⁵Average total height in feet and meters of dominant trees at 300 years of age.

CALIFORNIA FOREST PRACTICE RULES

Article 5 Standardized Stocking Sampling Procedures

1070 Stocking Sampling

The objective of this article is to describe the stocking sampling procedures that the timber owner or his agent shall use to determine if the stocking standards of the Act and rules have been met following the completion of a timber operation.

1071 Minimum Stocking Standards

Within five years after the completion of timber operations or as otherwise specified in the rules, a report of stocking on the entire area logged under the plan and shown on a revised map shall be filed with the Director by the timber owner or the agent thereof. If stocking is required to be met upon completion of timber operations the stocking report shall be submitted within six months of the completion of operations.

The minimum acceptable stocking standards on logged areas which were acceptably stocked prior to harvest are those specified in the Coast, Northern, and Southern Forest District rules. If not otherwise specified, the following minimum standards apply:

(a) On Site I timberlands as defined by the Board, the average residual basal area, measured in stems one inch or larger in diameter shall be at least 85 square feet per acre; or on Site II or lower shall be at least 50 sq. ft. per acre; or

(b) The area contains an average point count of 300 per acre on Site I, II, and III lands or 150 on Site IV and V lands as specified in PRC 4561.

See 14 CCR 912.7, 932.7 and 952.7 for information for the point count values of various size trees and for determining how sprouts will be counted toward meeting stocking requirements.

1072 Stocking Sampling Procedures

The procedures set forth in this article shall be adhered to when sampling for stocking. More than one procedure for sampling may be used on plans where more than one regeneration method or intermediate treatment is used in the timber operations.

The sampling procedures are divided into the following categories:

(a) Basal Area Stocking Sampling Procedure: This procedure shall be used where it is necessary to determine whether the specific basal area standards for such situations as the selection and shelterwood (preparatory steps) regeneration methods and commercial thinning intermediate treatment have been met.

(b) Point Count Stocking Sampling Procedure: This procedure shall be used where it is necessary to determine whether specific point count standards must be met. For example, the procedure can be used for the clearcut and seed tree regeneration methods.

(c) Combination Stocking Sampling Procedure: This procedure shall be used where stocking standards can be met using either basal area or point count, such as for the sanitation-salvage intermediate treatment, alternative prescriptions, or where exceptions to the stocking standards have been provided for in the rules and are specified in the plan.

(d) Waiver Request Procedure: This procedure may be used to request from the Director a waiver of sampling procedures provided in 14 CCR 1072 (a), (b), or (c) where, based upon an RPF's, an RPF supervised designee's, or owner of timberland's inspection, he/she has determined that the stocking requirements of the Act and rules have obviously been met.

1072.1 Number of Plots Required

There shall be at least one plot per acre, with a minimum of 20 plots, for each timber operating area sampled. The timber owner or his/her agent is encouraged, in lieu of sampling the entire logged area or area being sampled, to delineate by ocular estimate the least stocked 40 acres (16.187 ha) of the logged area or area being sampled and sample this area to determine if it is acceptably stocked. If the least stocked area sampled is determined to be acceptably stocked in accordance with these regulations, the entire logged area, or area being sampled, shall be assumed to be acceptably stocked. If the area sampled is not acceptably stocked the area sampled shall be regenerated to bring it into conformance and the remainder of the logged area shall be sampled, or the next least stocked 40 acres (16.187 ha) shall be sampled to determine whether the rest of the logged area is acceptably stocked.

CALIFORNIA FOREST PRACTICE RULES

The Director, in making the stocking inspection specified in PRC 4588 may, independent of the sample specified in the Report of Stocking, sample what he determines is the least stocked 40 acres (16.187 ha) of the logged area to determine if the area is stocked.

1072.2 Plot Layout

Plots shall be placed on the area being sampled in a uniform grid. The grid shall be considered uniform if the distance between lines does not exceed by two and one half times the distance between plots on the lines.

The starting point of each plot line shall be referenced to a survey corner if convenient or to a suitable, readily locatable permanent landmark and shall be indicated in the Report of Stocking and flagged in the field. The compass bearings shall be recorded in the Report of Stocking.

1072.3 Equipment

The following equipment and methods for measuring distance are acceptable when basal area, point count, or combination stocking sampling procedures are used. Hand compass and pacing may be used for locating plot centers. A measuring tape or other calibrated measuring device shall be used for determining the radius of plots. For basal area and combination stocking sample procedures, an angle-gauge, wedge prism, or other device capable of measuring ocularly a predetermined angle (to determine basal area) will normally be needed.

1072.4 Exclusions

Roads and landings that will not be regenerated, meadows, wet areas, rocky areas, and areas not normally bearing timber shall not be used as plot centers for sampling purposes. Stream protection zones may be excluded from the sample where stocking cannot be achieved due to legal restrictions on regenerating the zone and it is explained in the stocking report. Notwithstanding the provisions of 14 CCR 1072.2, a random right/left offset from the plot center may be used. Alternatively the plot may be treated as an unstocked plot for purposes of determining acceptable stocking. The reason for the offset shall be stated in the stocking report.

Offsets shall be in one-half chain (33 ft.) (10.06m) intervals at a right angle to the plot line with a maximum distance of 1.5 chains (99 ft.) (30.19m) allowed. The direction and distance of the offset, if any, shall be note on the plot sheet.

1072.5 Basal Area Stocking Sampling Procedure

The silvicultural rules of each forest district and the Act contain basal stocking standards to be met following the completion of a timber operation. The following procedure shall be used to determine if these stocking standards have been met: One or more basal area factors suitable for determining stocking shall be used. The same basal area factor shall be used on all of the plots on a sampling area. A countable tree for basal area is described in PRC 4528. If each plot has a minimum basal area equal to or greater than that specified in 1071 (a), or as required by the rules if different, then the plot shall be counted as stocked.

1072.6 Point Count Stocking Sampling Procedure

The silvicultural rules of each forest district and the Act contain point count stocking standards to be met following the completion of a timber operation. The following procedure shall be used to determine if these stocking standards have been met.

Since there are separate values for three different size classes, three circular concentric plots may be needed at each plot center. The following standards are for a 300 point count:

(a) For trees counted as one point each, a plot with a 6.80 foot radius is used (1/300th of an acre). If a countable tree of a value of at least one point is found in the plot, it is stocked, so recorded, and the timber owner or agent thereof moves on to the next plot center. If no countable tree is found, the next concentric plot is measured.

(b) For trees counted as three points each, a plot with a 11.78 foot radius is used (1/100th of an acre). If a countable tree of a value of at least three points is found in the plot, it is stocked, so recorded, and the timber owner or the agent thereof moves on to the next plot center. If no countable tree is found, the next larger concentric plot is measured.

CALIFORNIA FOREST PRACTICE RULES

(c) For trees counted as six points each, a plot with a 16.65 foot radius is used (1/50th of an acre). If a countable tree of a value of at least six points is found in the plot, it is stocked. If no countable trees of the required sizes are found in the three concentric plots, the plot center is recorded as being unstocked and the timber owner or agent thereof moves on to the next plot center. For point counts of 450 per acre, the three concentric circular plot radius sizes are: 5.55 feet (1/450th of an acre), 9.61 feet (1/150th of an acre), and 13.6 feet (1/75th of an acre). For point counts of 150 per acre, the three concentric circular plot radius sizes are: 9.61 feet (1/150th of an acre), 16.65 feet (1/50th of an acre), 23.55 feet (1/25th of an acre).

The point count values of various size trees and for determining how sprouts will be counted is found in 14 CCR 912.7, 932.7 and 952.7.

1072.7 Combination Stocking Sampling Procedure

The procedure is used where the silvicultural rules of each forest district and the Act allow the stocking standards to be met through combination of point count and basal area. The following procedure shall be used to determine if these stocking standards have been met: At each plot center the timber owner or agent thereof shall check for either basal area or countable trees. The same basal area factor shall be used on all plots in the sample. If the plot is not stocked with countable trees as specified in 14 CCR 1072.5, it shall be necessary to sample for countable trees as specified in 14 CCR 1072.6.

1073 Unacceptable Results

(a) No more than five unstocked plots shall be contiguous to each other. A contiguous unstocked plot is any plot within the rectangle constructed around the two adjacent plots on the same line and the three plots adjacent to them on the two nearest lines. See Figure 1073(a).

An unstocked plot shall not be counted as contiguous to another unstocked plot if any of the following occur:

(1) Where, in use of the point count or combination stocking sampling procedure, an unstocked plot has a countable tree located in the largest circular concentric plot described in the procedure.

(2) Where the forest practice rules allow only the basal area sampling procedure to be used, the continuity of the six contiguous plots may be considered broken if one or more of the contiguous unstocked plots meets the minimum stocking standards of the Act.

(b) If there are more than five unstocked plots contiguous to each other, the sample shall be assumed to be understocked except where application of the following gives a number of less than six.

$$\frac{(CUP) \times (SA)}{(NPS)} - \frac{(SIP) \times (0.5) \times (SA)}{(NPS)} \text{ is less than } 6$$

CUP---Number of contiguous unstocked plots

SA---Acres in sample area

SIP---Number of stocked intermediate plots

NPS---Number of plots in sample, excluding intermediate plots. An intermediate plot is a plot placed halfway between two unstocked plots in the sample.

CALIFORNIA FOREST PRACTICE RULES

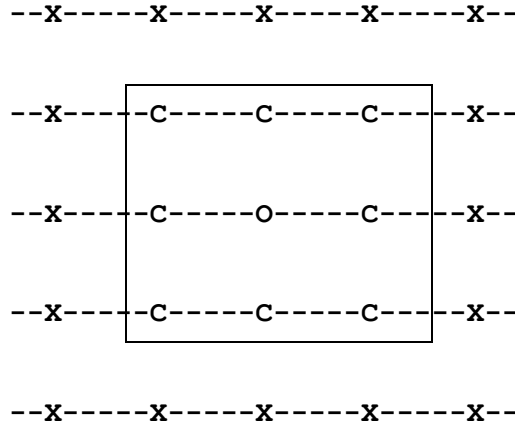

LEGEND

- | | |
|--------------------------|----------------------|
| O - Initial Plot | C - Contiguous Plots |
| X - Non-Contiguous Plots | - - - - Survey Line |

Figure 1073(a) Example of the rectangle enclosing contiguous plots

(c) If less than 55% of the plots are stocked when using the basal area, point count, or combination stocking sampling procedures, it is assumed that the area being sampled is understocked. The timber owner or agent thereof shall delineate the understocked areas in the report of stocking. If the timber owner or the agent thereof still believes the area to be stocked, another sample may be run. The second sample shall be laid out in the same manner as the first sample with the additional plots lying halfway between the initial plot lines. For statistical analysis, the two samples shall be combined and analyzed together.

1074 Waiver Request

The basal area, point count and combination stocking sampling procedures may be waived if the Director, and the owner of timberland or an RPF acting as agent for either the timber owner or owner of timberland, agree that the area is obviously stocked and each of the following conditions is fulfilled:

(a) A request for a waiver of sampling, if filed within five years after completion of timber operations, or as otherwise specified in the Board's rules.

(b) The owner of timberland or an RPF states in the request for a waiver of sampling to the Director that he/she or that RPF's supervised designee has examined the plan area after completion of timber operations and believes those harvested areas for which a waiver of sampling is being requested obviously meet the stocking requirements of the Act and the applicable rules or regulations of the Board.

1074.1 Waiver Approval

If the Director agrees that an area is obviously stocked, then the sampling procedures are waived. If the Director does not agree that the stocking requirements of the Act and applicable rules of the Board have been met, the following shall occur:

(a) The Director shall return the request for a waiver as unacceptable to the owner of timberland or the RPF making the request.

(b) The timber owner or an RPF acting as his/her agent shall use the point count, basal area, or combination stocking sampling procedure, as appropriate on the area, to determine if the stocking requirements of the Act and rules have been met. The results of this sampling shall be submitted to the Director.

CALIFORNIA FOREST PRACTICE RULES

1075 Report of Stocking

A Report of Stocking on a form acceptable to the Director, certifying that the area logged does not meet or meets minimum stocking standards, shall be submitted by the timber owner or the agent thereof to the Director within five years after completion of timber operations, or as otherwise specified in the rules. The report shall contain the following information:

- (a) Name, address, and telephone number of timber owner(s) or agent thereof.
- (b) The plan number.
- (c) Name of person performing the stocking sampling.
- (d) Map showing the sampling area, by sampling procedure, if more than one procedure is used; the plot locations indicating status as stocked or non-stocked.
- (e) The acreage of each sampling area.
- (f) The number of plot centers installed by sampling procedure.
- (g) The number of stocked plots by sampling procedure.
- (h) Certification by the timber owner or agent thereof.
- (i) Either the plot reference data specified in 14 CCR 1072.2 or direction as to where the plot reference can be obtained.

The timber owner or agent thereof who files the Report of Stocking shall maintain on file the detailed data on the stocking sampling until such times as a Report of Satisfactory Stocking is issued by the Director. This data shall be available for inspection by the Director and subject to use in enforcement proceedings.

Article 6 Stocking Standards for Substantially Damaged Timberlands

1080 Substantially Damaged Timberlands

[Renumbering of section 1080 to section 895.1 operative 7-1-2000]

1080.1 Stocking Requirements for Substantially Damaged Timberlands

(a) The stocking standards to be maintained or established where substantial damage has occurred prior to the start of timber operations, or where such damage has occurred following the start of timber operations but before a stocking report has been submitted or approved by the Director, are:

(1) On Sites III and better, the stocking shall consist of at least ten countable trees planted for each live tree harvested during conduct of salvage operations following the substantial damage, but need not exceed an average point count of 300 per acre (741.3 per ha). The number of live trees harvested shall be determined by stump count or by an equivalent procedure proposed by the RPF and approved by the Department.

(2) Where only dead, down, or dying trees were salvage logged following the substantial damage, no restocking is required.

(3) No restocking requirements need be met on substantially damaged timberlands on Sites IV and V after timber operations.

(b) If stocking standards were met, but substantial damage occurred before a report of stocking was approved by the Director, a report of stocking may be submitted and approved as specified in 14 CCR 1080.4(a).

1080.2 Timber Harvesting Plans for Substantially Damaged Timberlands

Where timber operations are to be conducted on any substantially damaged timberlands, they shall be designated and described in the Timber Harvesting Plan or the Emergency Notice of Timber Operations submitted to the Director.

1080.3 Stocking Distribution

Any establishment of trees to meet the stocking requirement of 14 CCR 1080 shall be planned to ensure the most feasible utilization of suitable and available growing space and growing stock. The location, spacing, and site preparation measures to meet this requirement shall be described in the THP as shall also the area of timberland qualifying for the stocking standards set forth herein. No more than two restocking efforts shall be required provided that such efforts are accomplished in a good and workman like manner.

CALIFORNIA FOREST PRACTICE RULES

1080.4 Stocking Reports for Substantially Damaged Timberlands

(a) In the event that timberland becomes substantially damaged before a stocking report is submitted to the Director, a report may be submitted by the timber owner or his agent stating that the area was adequately stocked prior to the occurrence of substantial damage. A report of stocking for substantially damaged timberlands shall be a certification to the Director by a timber owner or agent thereof that the stocking requirements of 14 CCR 1080.1 (a) and (b) have been met.

(b) The Director shall issue a satisfactory report of stocking if it can be certified, based upon first hand knowledge, that the area was adequately stocked prior to the destruction of stocking. The owner or agent may appeal the Director's denial of his certification to the Board.

(c) Should only a portion of the plan area be substantially damaged, separate stocking reports (one for the damaged area and one for the undamaged area) may be filed.

1080.5 Time Period to Meet Stocking Requirements

The restocking effort required by 14 CCR 1080.1 shall be accomplished within five years after completion of timber operations for salvage or harvest of timber from substantially damaged timberlands unless a longer period of time is needed and is approved by the Board for a specified area.

Article 6.5 Nonindustrial Timber Management Plan Administration

1090 Rule Application

Where the abbreviation THP, the term Timber Harvesting Plan, or the word plan is used in Chapter 4, Subchapters 1 through 6 and Chapter 4.5 it shall also mean Nonindustrial Timber Management Plan as specified in Article 7.5 of the PRC. In Subchapter 7 this equivalency will occur for all sections except 1031 through 1042.

1090.1 Timber Management Plan and Notice of Timber Operations Filing Locations

The Nonindustrial Timber Management Plan (NTMP) or Notice of Timber Operations (Notice) for proposed timber operations provided for by Article 7.5, Chapter 8, Part 2, Division 4 of the PRC (commencing with Sec. 4593) shall be submitted in writing to the Director and shall contain the information specified in 14 CCR 1090.5 at the Department of Forestry and Fire Protection Region/[Area] Office having jurisdiction for the timber operations. [NOTE: for CDF addresses, see Section 1032.]

1090.2 NTMP Submittal and Notice of Preparation

(a) A plan shall be submitted by the person who owns the timberland included in the plan.

(b) Where the timber is owned by parties other than the landowner, the landowner shall give prompt written notice of such plan to those parties.

(c) The plan submitter shall prepare and submit to the Director, with the plan, a Notice of Preparation to Harvest Timber (Notice of Preparation).

(1) If any proposed plan boundary lies within 300 ft. of any property owned by any person other than the plan submitter, or

(2) With any plan amendment that changes a plan boundary so that the new boundary lies within 300 ft. of any property owned by any person other than the plan submitter, or

(3) With any plan amendment that changes the silvicultural method if a Notice of Preparation was required for the plan by condition (1) or (2) above.

(d) A Notice of Preparation shall include the following information:

(1) The name of the plan submitter.

(2) The location of the plan area by county, section, township, and range, and the approximate direction and distance to the plan area from the nearest community or well-known landmark.

(3) The name of the nearest perennial blue line stream flowing through or downstream from the plan area.

(4) The acreage of the area to be included in the plan.

(5) The silvicultural method(s) proposed.

(6) The estimated earliest date that the Director may approve the plan as he/she has indicated in the NTMP instructions.

CALIFORNIA FOREST PRACTICE RULES

(7) A statement that the public may review the plan at the specified Regional Office of the Department and a reasonable per page copy fee set by the Director for additional copies.

(e) The person submitting the plan shall furnish to the Department at the time of submission of the plan, a list of all persons, including their mailing addresses, who hold legal or equitable title to property within 300 ft. of the plan boundary. Either a list compiled from the latest equalized assessment roll or a list provided by a title insurance company doing business in California shall be deemed sufficient for compliance with the subsection.

(f) The Department shall mail copies of the Notice of Preparation within two working days of receipt of the plan to all persons identified in (e) above.

(g) Prior to plan submission, the person submitting the plan shall post a copy of the Notice of Preparation at a conspicuous location that is easily visible to the public and near the plan site. Notwithstanding other Board rules, the notices required by Section 1032.10 of article 6.5 shall be completed prior to submission of the NTMP, and within counties with special rules, (14CCR, Subchapter 4, Art. 13, Subchapter 6, Art. 13) the noticing requirements will be the same as for a THP.

1090.3 Notice of Preparation-Distribution by Director

The Director shall distribute copies of each Notice of Preparation within two working days of receipt to:

- (a) The Office of the County Clerk of the county in which operations are proposed for posting at the customary place for posting environmental affairs.
- (b) The local Ranger Unit headquarters for posting.
- (c) At such other locations as the Director may deem desirable and feasible to provide adequate public notice.
- (d) Any additional distribution of the notice required by the rules of the Board for individual counties.

1090.4 Request for Notification of NTMP or Notice of Timber Operations Submission

(a) Each Regional Office of the Department shall maintain a list of NTMPs or Notice of Timber Operations submitted each day.

(b) When any person requests notice of submissions of timber management plans, the Director shall provide the person, free of charge, with a copy of the list of NTMPs or Notices of Timber Operations submitted on the date or dates requested. If no specific date is requested, a copy of the lists for the preceding week shall be provided.

1090.5 Contents of NTMP

The plan shall serve three functions: **1)** to provide information the Director needs to determine whether the proposed NTMP conforms to the rules of the Board; **2)** to provide information and direction for timber management so it complies with the rules of the Board and the management objectives of the landowner; and **3)** to disclose the potential effects of timber management to the public. For the plan to serve these functions, it shall, as a minimum, contain the following information:

- (a) Name, address, and telephone number of the timberland owner(s) or designated agent.
- (b) Name, address, and telephone number of the timber owner(s) (if different).
- (c) Name, address, telephone number, and registration number of RPF who prepared the plan.
- (d) A description of the plan area within which timber operations are to be conducted. The description shall include the following:
 - (1) U.S. Geological Survey (USGS) Quadrangle name(s) and date(s),
 - (2) township, range, and section number(s),
 - (3) county name(s),
 - (4) CALWATER 2.2 planning watershed number(s), and
 - (5) approximate acreage.
- (e) The forest district and subdistrict (if any) in which the NTMP is located.
- (f) A description of present and proposed plan area uses other than timber production.
- (g) A description by management unit(s) of the timber stand characteristics including species composition, age classes, projected growth, present stocking level, present volume per acre, size class distribution, stand management history, and potential pest or protection problems. The description shall provide the basis for the information provided.

CALIFORNIA FOREST PRACTICE RULES

- (h) A description by management unit(s) of the proposed management objectives, including a discussion of projected timber volumes and sizes available for timber harvesting.
- (i) A description by management unit(s) of proposed activities to achieve the management objectives. This must include: 1) projected frequencies of harvest, 2) silvicultural prescriptions for harvesting, 3) type of yarding systems to be used for each area; 4) anticipated interim management activities which may result in rule compliance questions (i.e. erosion control maintenance).
- (j) The period of time over which growth will be balanced with harvest.
- (k) A description of any cultural or historical resources known to exist with a description of possible impacts and protection methods to be used during timber operations.
- (l) Whether a timberland conversion certificate is in effect, its date of expiration, and its identification number.
- (m) Whether a timber harvesting plan is on file with the Department for any part of the plan area and if a Report of Satisfactory Stocking has been issued by the Department (show plan number).
- (n) Information on the presence and protection of any known key habitat or individuals of any threatened or endangered plant or animal species that are listed in DFG inventories prepared pursuant to the F&GC or any species of special concern as designated by the Board in these rules.
- (o) A description of potential impacts and protections for the quality and beneficial uses of waters within watercourses, lakes, and wet areas.
- (p) A description of soils, surface erosion hazard, mass wasting erosion hazard, and erosion control measures.
- (q) A description of the existing and proposed road system to be used in implementation of the management plan.
- (r) A description of how the site preparation standards and stocking standards will be met.
- (s) A description of the proposed yarding methods including protection of residual trees, watercourse crossings, operation on unstable areas.
- (t) A description of slash treatment for site preparation, fire protection and pest protection consideration.
- (u) A description of the cumulative effects analysis with supporting information, including impact of projected harvesting over the life of the plan.
- (v) A copy of the forest practice regulations in effect at the time of submission.
- (w) On a USGS quadrangle or equivalent topographical map of a scale not less than 2" to the mile, the following information shall be clearly provided. Additional maps may be required to show specific details, and may be planimetric. Color coding shall not be used. A legend shall be included indicating the meaning of the symbols used. See the district rules for the appropriate minimum mapping acreages.
 - (1) Boundaries of management plan(s) and management unit(s).
 - (2) Boundaries of regeneration methods, intermediate treatments, special harvesting methods, and alternative prescriptions that are to be applied.
 - (3) Boundaries of yarding (logging) systems, if more than one system is to be used.
 - (4) Location of public roads within the plan area, and private roads appurtenant to the timber operations where such roads are under the ownership or control of the timberland owner and are contiguous with the plan area, and classification of all proposed and existing logging roads as permanent, seasonal, or temporary roads.
 - (5) Probable location of proposed and existing landings in the watercourse and lake protection zone, and landings outside the zone that are greater than 1/4 acre in size or whose construction involves substantial excavation.
 - (6) Road failures on existing roads to be reconstructed.
 - (7) Location of all existing and proposed permanent watercourse crossing drainage structures and temporary crossings on Class I and II watercourses on roads; if a permanent culvert is involved, its minimum diameter shall be provided.
 - (8) Location of area(s) of high or extreme erosion hazard rating.
 - (9) Location of all watercourses with Class I, II, III, or IV waters.
 - (10) Location of known unstable areas or slides.
 - (11) Location of understocked areas and other areas not normally bearing timber to at least a 20-acre minimum, or as specified in the district rules.

CALIFORNIA FOREST PRACTICE RULES

(12) Location of boundaries of timber-site classes needed for determination of stocking standards to be applied, down to at least a 10-acre minimum or as specified in the district rules.

(13) Location of unique areas including, Coastal Commission Special Treatment Areas or any special treatment area.

(14) A soils map where available.

(x) Any additional information that is submitted on separate pages shall be clearly marked "plan addendum" and shall bear the date on which it was prepared.

(y) Explanation and justification for, and specific measures to be used for, tractor operations on unstable areas, on slopes over 65%, and on areas where slopes average over 50% and the EHR is high or extreme.

(z) Explanation and justification for tractor operations in areas designated for cable yarding.

(aa) Winter period operating plan where appropriate.

(bb) Explanation and justification for use of watercourse, marshes, wet meadows, and other wet areas as landings, roads, or skid trails.

(cc) Explanation and justification of any in-lieu or alternative practices for watercourse and lake protection.

(dd) Explanation of alternatives to standard rules for harvesting and erosion control.

(ee) Explanation and justification for landings that exceed the maximum size specified in the rules.

(ff) Any other information required by the rules or the Act to be included in the plan. The district rules provide for exceptions and alternatives to standard requirements that require inclusion of information in the NTMP.

(gg) Where roads, watercourse crossings, and associated landings in the logging area will be abandoned, the methods for abandonment shall be described.

(hh) On a map complying with subsection 1090.6(x), the locations and classifications of roads, watercourse crossings, and landings to be abandoned shall be shown.

(ii) A certification by the RPF preparing the plan that he, she, or a designee personally inspected the area.

1090.6 Notice of Timber Operations

Following confirmation by the non-industrial tree farmer that all necessary field work is functional and useable (including flagging or marking), the non-industrial tree farmer who owns, leases, or otherwise controls or operates on all or any portion of any timberland within the boundaries of an approved Timber Management Plan shall submit a Notice of Timber Operations including the certification required by PRC 4594.6 to the appropriate office of the Department. Timber operations may commence immediately unless the notice has been filed by mailing, in which case operations may commence three days after the notice has been mailed.

1090.7 Notice of Timber Operations Content

The purpose of the Notice of Timber Operations is to provide guidance for implementation of the standards and protective measures in the approved NTMP or most recent amended NTMP and the applicable rules of the Board. For the Notice to serve these functions, it shall as a minimum, contain the following:

(a) Identification number of the NTMP;

(b) The name and address and phone number of the timberland owner, the timber owner, the RPF, the Licensed Timber Operator and number, and the person responsible for on the ground supervision of the timber operations.

(c) Expected dates of commencement and completion of timber operations.

(d) A legal description land use survey of the area of the NTMP on which timber operations will be conducted.

(e) Identification of silvicultural prescriptions to be applied.

(f) The type of heavy equipment to be used for yarding or road construction.

(g) A statement that no archeological sites have been discovered in the harvest area since the approval of the NTMP.

(h) A statement that no listed species has been discovered in the cumulative impacts assessment area since the approval of the NTMP.

(i) A statement that there have been no physical environmental changes in the cumulative impacts assessment area that are so significant as to require any amendment of the NTMP.

CALIFORNIA FOREST PRACTICE RULES

- (j) Special provisions, if any, to protect any unique area within the area of timber operations.
- (k) Instructions on felling, yarding, road construction or reconstructions, hauling, erosion control work, site preparation, erosion control maintenance, winter operations, watercourse protection measures and slash treatment.
- (l) A certification by the RPF that the notice as submitted will carry out:
 - (1) The best management practices for the protection of the beneficial uses of water, soil stability, forest productivity, and wildlife as required by the current rules of the Board, or
 - (2) Is consistent with the plan and will not result in significant degradation of the beneficial uses of water, soil stability, forest productivity, or wildlife or be in violation of applicable legal requirements.
- (m) A verification that the LTO has been briefed by the RPF on the content of the notice and intentions of implementation to comply with the management plan.
- (n) On a USGS quadrangle or equivalent map of a scale not less than 2" to the mile, the following information pertinent to the Notice of Operations shall be clearly provided. Additional maps may be required to show specific details, and may be planimetric. Color coding shall not be used. A legend shall be included indicating the meaning of the symbols used. See the district rules for the appropriate minimum mapping acreages.
 - (1) Boundaries of area to be harvested (quadrangle map or its equivalent).
 - (2) Boundaries of areas for specified regeneration methods, intermediate treatments, special harvesting methods, and alternative prescriptions that are to be applied.
 - (3) Boundaries of areas for specified yarding (logging) systems, if more than one system is to be used.
 - (4) Location of public roads within the Notice area, and private roads appurtenant to the timber operations where such roads are under the ownership or control of the timberland owner, and are contiguous with the Notice area, and classification all proposed and existing logging roads as permanent, seasonal, or temporary roads.
 - (5) Location of proposed and existing landings in the watercourse and lake protection zone, and landings outside the zone that are greater than 1/4 acre in size or whose construction involves substantial excavation.
 - (6) Road failures on existing roads to be reconstructed.
 - (7) Location of all existing and proposed watercourse crossings on logging and tractor roads; if a permanent culvert is involved, its minimum diameter shall be provided.
 - (8) Designate areas of high or extreme erosion hazard rating, if more than one.
 - (9) Location of watercourse with Class I, II, III or IV waters.
 - (10) Location of known unstable areas or slides.
 - (11) Location of unique areas.
- (o) Any other information the Board provides by regulation to meet its rules and the standards of this chapter.
- (p) A statement that the Notice of Timber Operations conforms to the provisions of the approved NTMP.

1090.8 NTMP Professional Judgment

Where the rules or these regulations provide for the exercise of professional judgment by the RPF or the Director, if there is a disagreement and if requested by either party, they shall confer on the NTMP area during the NTMP review inspection and reach agreement, if possible, on the conditions and standards to be included in the plan.

1090.9 Plan Submitter Responsibility

The plan submitter, or successor in interest, shall:

- (a) Ensure that an RPF conducts any activities which require an RPF.
- (b) Provide the RPF preparing the plan or amendments with complete and correct information regarding pertinent legal rights to, interests in, and responsibilities for land, timber, and access as these affect the planning and conduct of timber operations.
- (c) Sign the NTMP certifying knowledge of the plan contents and the requirements of this section.

CALIFORNIA FOREST PRACTICE RULES

(d) Within five (5) working days of change in RPF responsibilities for NTMP implementation or substitution of another RPF, file with the Director a notice which states the RPF's name and registration number, address, and subsequent responsibilities for any RPF required field work, amendment preparation, or operation supervision. Corporations need not file notification because the RPF of record on each document is the responsible person.

(e) Provide a copy of the approved NTMP and Notice of Timber Operations to the LTO.

(f) Notify the Director prior to commencement of site preparation operations. Receipt of a burning permit is sufficient notice.

(g) Provide the RPF preparing the Notice and LTO each a copy of the current NTMP and subsequent amendments.

1090.10 Registered Professional Forester Responsibility

(a) Upon submission of a NTMP, the RPF who prepares and signs a plan is responsible for the accuracy and completeness of its contents.

(b) The RPF preparing the plan shall: 1) Inform the Director and landowner by phone or letter if he or she will be attending the review inspection; and 2) Provide the landowner a copy of the rules of the Board in effect on the date of NTMP approval.

(c) The RPF preparing the Notice shall list or describe in the Notice any work which will be performed by the RPF Notice preparer or supervised designee. This may include, but is not limited to, field work in identifying watercourse and lake protection zones or special treatment areas, marking trees, or other activities. The RPF is only responsible for the activities required of the RPF by the rules of the Board and those activities for which he or she is employed.

(d) The RPF preparing the Notice shall, in writing, inform the plan submitter(s) of their responsibility pursuant to Section [1090.9] of [this] Article [6.5] for compliance with the requirements of the Act and, where applicable, Board rules regarding site preparation, stocking, and maintenance of roads, landings, and erosion control facilities. [NOTE: CDF will be working with the Board, Barclays and OAL to correct the language in this Section (d).]

1090.11 Interaction Between RPF and LTO on Notice of Timber Operations

From the start of the preparation of the Notice of Timber Operation preparation but before commencement of operations the responsible RPF, shall meet with either the LTO, or supervised designee, who will be on the ground and directly responsible for the harvesting operation. The meeting shall be on site if requested by either the RPF or LTO. If any amendment is incorporated to the notice by an RPF after the first meeting, that RPF or supervised designee shall comply with the intent of this section by explaining relevant changes to the LTO; if requested by either the RPF or LTO, another on-site meeting shall take place.

The intent of any such meeting is to assure that the LTO:

(a) Is advised of any sensitive on-site conditions requiring special care during operations.

(b) Is advised regarding the intent and applicable provisions of the approved notice including amendments.

1090.12 Licensed Timber Operator Responsibilities

Each Licensed Timber Operator shall:

(a) Inform the responsible RPF and plan submitter, either in writing or orally, of any site conditions which in the LTO's opinion prevent implementation of the Notice.

(b) Be responsible for the work of his or her employees and familiarize all employees with the intent and details of the operational land protection measures of the Notice and amendments that apply to their work.

(c) Keep a copy of the applicable approved Notice and amendments available for reference at the site of active timber operations.

(d) Comply with all provisions of the Act, Board rules and regulations, the applicable Notice and any approved amendments.

CALIFORNIA FOREST PRACTICE RULES

1090.13 Notification of Commencement of Operations

For each Notice of Timber Operations submitted, within fifteen days before, and not later than the day of the start up of a timber operation, the Submitter of the Notice, unless the NTMP identifies another person as responsible, shall notify CDF of the start of timber operations. The notification, by telephone or by mail, shall be directed to the appropriate CDF Ranger Unit Headquarters, Forest Practice Inspector, or other designated personnel.

1090.14 NTMP Deviations

(a) "Minor deviations" means any change, minor in scope, in a plan which can reasonably be presumed not to make a significant change in the conduct of timber operations and which can reasonably be expected not to significantly adversely affect timberland productivity or values relating to soil, water quality, watershed, wildlife, fisheries, range and forage, recreation, and aesthetic enjoyment or to result in a violation of the applicable water quality control plan.

(b) All other changes are presumed to be substantial deviations because they could significantly affect the conduct of timber operations and potentially could have a significant adverse effect on timber productivity or values relating to soil, water quality, watershed, wildlife, fisheries, range and forage, recreation, and aesthetic enjoyment. Such actions include, but are not limited to:

(1) Change in location of timber harvesting operations or enlargement of the area or volume planned to be cut.

(2) Change in the silvicultural method and cutting system on any portion of the plan area.

(3) Change in type or location of logging (yarding) system or basic type of equipment.

(4) Change in location, nature or increase in length of proposed logging roads incorporating one or more of the following criteria:

(A) Any road in a Watercourse or Lake Protection Zone or where sidecast will extend into the Watercourse or Lake Protection Zone.

(B) Any road located in an extreme Erosion Hazard Rating area.

(C) Any road where the average side slope exceeds 50%.

(D) Any road where unstable areas, active soil movement, or slide areas must be traversed.

(E) Any increase in gradient allowed by the District Rules as an exception and not provided for in the original plan.

(F) Any road extension of more than 600 ft. (182.9m).

(5) Any use of existing roads not shown in the original plan when reconstruction work to allow for vehicle travel will be substantial. Substantial work on an existing road means more than minor repair and dressing of the travel surface and removal of vegetation to allow for vehicle passage.

(6) Use of any roads not shown in the plan which would affect the key habitat of rare or endangered species or other critical wildlife habitat.

(7) Enlargement of landings where such enlargement was not justified in the original plan.

(8) Any change of operation in, or designation of, the Watercourse or Lake Protection Zone.

(9) Any downgrading of Watercourse classification.

(10) A change to winter operation where summer operation was previously specified.

1090.16 Notice NTMP of Filing

(a) The Director shall prepare a notice of filing which shall contain the basic information contained in the Notice of Preparation (14 CCR 1090.2) plus the assigned timber management plan number.

(b) Within two working days of the date the plan is filed, the Director shall transmit copies of the Notice of Filing to:

(1) The person submitting the plan.

(2) The office of the County Clerk of the county in which the operations are proposed. The notice shall be posted at the normal place for posting environmental notices.

(3) The local Ranger Unit headquarters for posting.

(4) At such other locations as the Director may deem desirable and feasible to provide adequate public notice.

(5) All public agencies having custodial responsibility for lands within 300 ft. of the NTMP boundary.

CALIFORNIA FOREST PRACTICE RULES

1090.17 Agency and Public Review for the NTMP

(a) Upon receipt of the filed plan in accordance with 14 CCR 1090.16, the Director shall place it, or a true copy thereof, in a file available for public inspection, and shall transmit a copy to the Department of Fish and Game, the Department of Conservation, Division of Mines and Geology, and to the appropriate California Regional Water Quality Control Board, the Department of Parks and Recreation, the county planning agency and, if the areas are within their jurisdiction, to the California Tahoe Regional Planning Agency and the California Coastal Commission and all other agencies having jurisdiction by law over natural resources affected by the plan.

(b) The Director shall also transmit a copy of any specific plan to any person who has made a written request therefore.

(c) The Department shall bill such persons for the cost of providing such copies and such monies shall be paid to the Department.

The Director shall invite written comments, and will consider these comments. All comments regarding plans shall be in writing and shall be addressed to the Director at the regional office where the plan is filed.

1090.18 Director's Determination

The Director shall have 45 days from the date the initial inspection is completed, or in the event the Director determines that such inspection need not be made, 45 days from the date of filing of an accepted plan in accordance with 14 CCR 1090.16 or such longer period as may be mutually agreed upon by the Director and the person submitting the plan, to determine if the plan is in conformance with the applicable rules adopted by the Board. The Director shall insure that an interdisciplinary review team has had an opportunity to review each plan before determining if the plan conforms to the rules of the Board. The Director shall consider all written comments regarding the plan.

1090.19 Review Teams to be Established to Review Timber Management Plan

Interdisciplinary review teams shall be established by the Director to review plans and assist the Director in the evaluation of proposed timber management plan(s) and its impacts on the environment. The Review Team composition, function, tasks and procedures shall be the same as those described in 14 CCR 1037.5.

1090.20 Nonconformance of NTMP

If the Director determines that a plan is not in conformance with the rules of the Board the plan shall be returned in accordance with 14 CCR 1054. In addition, the Director shall state any changes and reasonable conditions that in the Director's professional judgment are needed to bring the plan into conformance with the applicable rules of the Board and offer to confer with the RPF in order to reach agreement on the conditions necessary to bring the plan into conformance.

1090.21 Conformance of NTMP

If the Director determines that the plan is in conformance with the rules of the Board, then the person submitting the plan shall be notified timber operations thereunder may only commence after submission of a Notice of Timber Operations as prescribed in 14 CCR 1090.7.

1090.22 Notice of Conformance of the NTMP

Within ten working days of the date a plan is found in conformance, the Director shall transmit a notice thereof to the agencies and persons referred to in 14 CCR 1090.17 and for posting at the places named in 14 CCR 1090.16. A copy of the notice shall be filed with the Secretary for Resources. The notice of conformance shall include a written response of the Director to significant environmental points raised during the evaluation process.

1090.23 Public Inspection

Notices of Conformance, pursuant to 14 CCR 1090.22 and notices of approval by the Board, pursuant to 14 CCR 1054, shall be available for public inspection, and a list of such notices shall be posted on a weekly basis in the Office of the Resources Agency. Each such list shall remain posted for a period of 30 days.

CALIFORNIA FOREST PRACTICE RULES

1090.24 Amendment

Amendments proposing substantial deviation from an original plan shall be submitted to the Director in writing by the person who submitted the original plan, or the successor in interest. Substantial deviations shall not be undertaken until such amendment has been filed and acted upon by the Director in the manner as required in Article 6.5 of Subchapter 7 of these rules for the original plan.

1090.25 Report Minor Deviations

Minor deviations may be undertaken by the person who submitted the NTMP or Notice without submission of an amendment to the plan and shall be reported immediately in writing to the Director.

Actions described in 14 CCR 1090.14 which are normally presumed to be substantial deviations may, in a given instance, be minor deviations. Actions listed as substantial deviations in 14 CCR 1090.14 but considered to be minor by the submitter, may be undertaken only if the person who submitted the plan submits the proposed deviation in writing to the Director for review and receives approval.

Approval shall be given if the Director determines that the proposed minor deviation conforms to the standards provided in 14 CCR 1090.14(a). The Director shall have 5 working days to act on the application. If the Director or the representative of the Director does not act within 5 working days of receipt of such a deviation, timber operations may commence pursuant to such amendment.

1090.26 Change of Ownership

Any change in ownership of land must be reported to the Director by the new landowner within 180 days of the date such change is recorded in the county where the property is located. Also, before the passage of title, it shall be responsibility of the seller to notify the purchaser of either the timber or timberland of their responsibility for compliance with the stocking standards of the Act and the rules of the Board.

After a plan is found in conformance with the rules and regulations of the Board, the Director may file a Notice of Stocking Requirements on the property with the recorder of the county within which the plan is located if any area logged under a Notice of Timber Operations has not had a report of satisfactory stocking issued by the Director.

1090.27 Cancellation of Plans

All parties, who submitted plans or their successors, must sign the request to the Director for cancellation of a plan. Once cutting has commenced, the plan may not be canceled except as to lands not harvested.

Article 6.75 Sustained Yield Plan

1091.1 Sustained Yield Plan

(a) General. This Article establishes requirements applicable to Sustained Yield, watershed impacts, and fish and wildlife.

(b) Authority and Intent This Article carries out the Legislature's direction that the Board adopt regulations to assure the continuous growing and harvesting of commercial forest tree species and to protect the soil, air, fish and wildlife, and water resources in accordance with the policies of the Forest Practice Act (FPA). Those policies include creating and maintaining a system of timberland regulations and use which ensures that timberland productivity is maintained, enhanced and restored where feasible and the goal of maximum sustained production (MSP) of high-quality timber products is achieved while giving consideration to environmental and economic values. The Sustained Yield Plan (SYP) may be submitted at the option of the landowner and is intended to supplement the THP process by providing a means for addressing long-term issues of sustained timber production, and cumulative effects analysis which includes issues of fish and wildlife and watershed impacts on a large landscape basis.

In the interpretation and implementation of this Article, it is recognized that the accuracy of, and therefore the need for, detailed future projections becomes less as the time horizon lengthens. It is not the intent of this Article that speculation shall be promoted such that analyses shall be undertaken which would produce only marginally reliable results or that unneeded data would be gathered. Moreover, it is recognized that in certain cases, landowners, and particularly owners of smaller areas, may not have nor can be reasonably expected to obtain or project information which otherwise might be helpful. It is the intent of this Article that the requirements for informational or analytical support for a SYP shall be guided by the principles of

CALIFORNIA FOREST PRACTICE RULES

practicality and reasonableness; no information or analysis shall be required which in the light of all applicable factors is not feasible. However, it is the intent of this Article that all potential adverse environmental impacts resulting from proposed harvesting be described, discussed and analyzed before such operations are allowed. Should such analysis not be included in the SYP, it must be contained in those THPs which rely on the SYP, including any impact discovered after the SYP is approved.

1091.2 Relation to THPs

If submitted, a SYP shall address issues of sustained timber production, watershed impacts and fish and wildlife by preparing an SYP for a Management Unit. The SYP shall not replace a THP. However, to the extent that sustained timber production, watershed impacts and fish and wildlife issues are addressed in the approved SYP, these issues shall be considered to be addressed in the THP; that is the THP may rely upon the SYP.

1091.3 Definitions

"Management Unit" means the part or parts of timberland ownership which are analyzed together as part of an SYP and may include areas outside of an ownership when addressing watershed and wildlife issues. The Management Unit shall be limited to one forest district. The landowner has the option of including within their management unit their entire ownership within the forest district and any areas outside the district that the Director agrees are part of a logical management unit, or they may divide the ownership into management units based on administrative, regulatory and ecological factors with concurrence from the Director. The Management Unit must include one or more planning watersheds, and may include associated resource assessment areas.

1091.4 Sustained Yield Plan Contents

(a) **Contents of SYP** If a SYP is submitted, it shall be prepared under the supervision of and signed by an RPF and shall include the following information:

- (1) Name and Address of timber and timberland owner.
- (2) Ownership description and location, including legal descriptions and maps depicting the ownership and Management Units which shall be at a scale sufficient to allow the Director to determine the area covered by the SYP.
- (3) Management objectives for resources addressed in the SYP, including timber products.
- (4) General narrative description of the forest types, fish and wildlife habitats and watercourses and lakes.
- (5) Descriptions of Management Units (e.g., planning watersheds or larger areas) and rationale for Management Unit selection.
- (6) Identification and mapping of Planning watersheds classified as sensitive watersheds and description of the measures taken to protect resources within those watersheds.

1091.4.5 Sustained Timber Production Assessment

(a) Consistent with the protection of soil, water, air, fish and wildlife resources a SYP shall clearly demonstrate how the submitter will achieve maximum sustained production of high quality timber products while giving consideration to regional economic vitality and employment at planned harvest levels during the planning horizon. The average annual projected harvest over any rolling 10-year period, or over appropriately longer time periods for ownerships which project harvesting at intervals less frequently than once every ten years, shall not exceed the long-term sustained yield estimate for a SYP submitter's ownership.

(b) Where a SYP is based upon data on file with the Director, such data shall be updated every 10 years. Proprietary information shall be treated consistent with PRC 21160.

(c) Each sustained timber production assessment shall include:

(1) A summary table of Wildlife Habitat Relationships compositions and stand structure types (WHR), or comparable stand structure types within forest vegetation types with their respective acreage. For an ownership's specific stand structure types, the RPF shall provide a written description of the stand structure and characteristics which define each type, and comparisons of those types to WHR typing. The WHR system, which is herein incorporated by reference, and its uses is described in "A Guide to the

CALIFORNIA FOREST PRACTICE RULES

California Wildlife Habitat Relationships System", California Department of Fish and Game, March 1988.

(2) An estimate of the long-term sustained yield of the ownership stated in terms of board feet per year or cubic feet per year, or other reasonable measurement consistent with products chosen by the owner, and a description of how the estimate was reached. For ownerships that have not attained long-term sustained yield, the SYP shall estimate and justify the transition period necessary to achieve long-term sustained yield.

(3) A projection of growth and harvest for each WHR type or comparable stand structure type within forest vegetation type over each 10 year period in the planning horizon, and a description in narrative form of the accuracy and methodology used to estimate growth.

(4) A discussion of the accuracy of the inventory data for the management unit and/or ownership. Inventory data, models and growth and harvest projections utilized for harvest scheduling projections shall be available for confidential audits by reviewing agencies along with the basis for such data, including but not limited to the cruise design and sample plot data and statistical validity of such estimates. The SYP shall describe how the submitter will, over time, make reasonable progress to improve inventory estimates for the major WHR or vegetation types, with a goal of achieving standard errors that are no greater than 15% of their respective inventory estimates within the effective period of the SYP.

The major WHR types include all tree-dominated habitats in size classes 4, 5, and 6 with canopy closure classes of S, P, M, and D.

(5) A description of the prescriptions applied to each stand type projected. A narrative discussion of the methods used to project inventory, growth and harvest and WHR type or comparable stand structures type.

(d) The use of Spreadsheet Assisted Resource Analysis (SARA) planning model, Cooperative Redwood Yield Project Timber Output Simulator (CRYPTOS), and California Conifer Timber Output Simulator (CACTOS) growth models and WHR types are encouraged in order to aid in the Departmental review.

1091.5 Fish and Wildlife Assessment

The following fish and wildlife issues shall be addressed in an SYP:

(a) Assessment Area. The area for the fish and wildlife impacts assessment shall be at least the Management Unit under the SYP and may include the entire ownership within a forest district. Areas outside the ownership may be included as necessary to assess the potential individual or cumulative effect of timber operations.

In areas with multiple ownerships, landowners may cooperate to establish a management unit and develop a fish and wildlife habitat assessment and management plan.

(b) Impacts to be addressed. The Assessment shall address threatened, endangered and sensitive species and other fish and wildlife species which timber operations could adversely impact, resulting in significant adverse individual or cumulative impacts. The Assessment shall address, as feasible, such species' habitat needs and the availability, shapes and distribution of habitats in relation to harvest schedule and growth projections and the impacts of harvesting on such habitats. The SYP shall discuss and include feasible measures planned to avoid or mitigate potentially significant adverse environmental effects on such fish and wildlife. The plan may also discuss positive effects of the timber or timberland owner's operations on fish and wildlife.

For the initial ten year period, maps by Management Unit showing significant changes to WHR types or stand structure types that are likely to result from projected timber operations shall be included. For the remaining periods within the planning horizon, type changes shall, at a minimum, be discussed in a narrative manner (including tabular analyses by management unit) and may include maps.

(c) Where significant impacts are identified and feasible mitigation is not available, a THP relying upon the SYP shall address these remaining impacts. Reasonable Mitigation considered but rejected as infeasible shall be identified.

1091.6 Watershed Assessment and Planning

The following watershed issues shall be addressed in an SYP:

(a) Assessment Area. The minimum assessment area shall be no less than a planning watershed. The assessment area may include multiple watersheds within a Management Unit, and areas outside the ownership may be included.

CALIFORNIA FOREST PRACTICE RULES

(b) Impacts Analysis and Mitigation. The Assessment shall include an analysis of potentially significant adverse impacts, including cumulative impacts, of the planned operations and other projects, on water quality, fisheries and aquatic wildlife.

(c) The SYP shall contain a description of the individual planning watersheds in sufficient detail to allow a review of the analysis of impacts.

(1) For all planning watersheds in the ownership within a forest district descriptions shall include as appropriate:

(A) Estimate of the stand structure type acreage and percent composition of the watershed by decade.

(B) General maps and descriptions of unstable areas and unstable soils known to the plan submitter to be actively or potentially discharging sediment, as well as those mapped by public agencies.

(2) For the initial ten year period, for all planning watersheds in which harvesting will take place, descriptions shall include as appropriate:

(A) Map of existing roads and approximate location and miles of proposed new, reconstructed and abandoned roads.

(B) Estimate of the SYP submitter's ownership acres of forest types to be harvested by silvicultural method and yarding method, and the location of submitter's approved and submitted THPs and presently projected future timber operations.

(C) A general description of areas known to be sensitive to ground disturbance and present sources of erosion.

(d) The SYP shall also discuss and include feasible measures planned to mitigate or avoid significant adverse impacts. Where significant impacts are identified and feasible mitigation is not available, a THP relying upon a SYP shall address these remaining impacts. The SYP submitter shall utilize any one or a combination of methods to assess adverse watershed impacts including but not limited to:

(1) Board of Forestry Technical Rule Addendum #2 (14CCR 912.9, 932.9, 952.9).

(2) The use of a Cumulative Watershed Effects Analysis, including the Equivalent Roaded Area (ERA) method, for screening planning watersheds to determine whether watershed-specific thresholds of concern have been exceeded when appropriate.

(3) Other methods proposed in the SYP and approved by the Director.

(e) Multiple Ownerships. In areas with multiple ownerships, landowners may cooperate to establish a management unit and develop a watershed assessment.

1091.7 Limitation on Information Requirements

Where landowners do not cooperate to develop a watershed or fish and wildlife assessment, or where a management unit is adjacent to lands operated by landowners or timber owners who have not submitted a SYP, the information required of a SYP submitter regarding past, present and reasonably foreseeable probable future projects shall be limited to information regarding the same ownership, to matters of public record, readily available to the submitter and shall be guided by the principles of practicality and reasonableness. The sufficiency of the information provided in a SYP to evaluate environmental effects shall be judged in light of what is reasonably feasible and necessary.

1091.8 Compliance and Effectiveness Evaluation

The SYP shall include provisions for determining the compliance with and effectiveness of the measures adopted in the SYP to mitigate or avoid significant environmental effects. Such provisions may include evaluation by the SYP submitter and evaluation of affected areas with representative conditions. Progress reports shall be provided periodically to CDF at their request. Such evaluations shall be developed in consultation with the Director and appropriate review agencies.

1091.9 SYP Effective Period

The effective period of SYP shall be no more than ten years.

CALIFORNIA FOREST PRACTICE RULES

1091.10 Review of Sustained Yield Plan (SYP)

The Director shall review and approve or disapprove a SYP. The Director's determination shall be based on multi-disciplinary review used to determine whether the SYP satisfies the requirements of MSP and, in case of watershed and fisheries and wildlife issues, whether the SYP identifies potentially significant adverse impacts and includes feasible measures necessary to mitigate or avoid such impacts and is consistent with 14 CCR 897 (b). Where significant impacts are identified and feasible mitigation is not available, a THP relying upon the SYP shall address these remaining impacts. Reasonable Mitigation considered but rejected as infeasible shall be identified.

For purposes of PRC 4582.7 submission of a SYP shall be deemed to constitute agreement by the SYP submitter to extend the review and comment periods to the times specified in this article.

(a) Within 20 days of the receipt of an SYP, the Director shall determine if the SYP is in proper order, and meets the informational requirements of the rules, and if so, the SYP shall be filed. If the SYP is not acceptable for filing the Director shall return the SYP with written specifications of the deficiencies.

Where the Director does not make this determination within 20 days the plan shall be deemed filed. Once the SYP is accepted for filing the Director shall have 45 days or a longer period as mutually agreed to by the submitter and the Director to review and determine if the SYP contains sufficient and complete information to permit further review by the public and other agencies. If it does not, the Director will communicate with the submitter with written specification of the deficiencies including any information necessary to review and analyze the SYP. When the submitter provides adequate written response to each of the deficiencies, the SYP will be scheduled for further review. The Director shall deny the SYP if the information is not provided or is insufficient.

Once the SYP is ready for public and agency review the Director shall schedule a date for the start of a 90 day or longer period as mutually agreed to by the submitter and the Director.

(b) The Director shall schedule the SYP for the 90 day review as the SYP is determined to be ready for further review while considering departmental workload.

(c) Public Notice of SYP. The Director shall 15 days prior to the start of the 90 day scheduled review transmit notice to the public and agencies consistent with the noticing requirements of sections 1037.5 and 1037.1 b(1-5). The notice shall advise the public of the name of the submitter, geographic location of the SYP, where a copy of the SYP can be reviewed or obtained and when and where the public hearing will be held.

(d) Public Hearing. The Director shall hold a public hearing on the SYP within 45 days from the start of the Public Review Period. The SYP submitter shall participate with the Director in that hearing.

(e) Determination Period. At the end of the review and comment period the Director shall have 30 days to review public input, consider recommendations and mitigation measures of other public agencies, respond in writing to the issues raised and determine if the SYP is in conformance with the rules. Within this period, the Director shall make a determination of conformance.

(f) SYP Disapproval. If the Director disapproves a SYP, the Director shall provide written reasons for disapproval that conform with section 1054.

1091.11 Appeals

Appeals of SYP's shall be the same as provided in the FPA for THPs. For Head of Agency Appeals, the appealing agency shall have 10 days from the Director's determination date to notify the Board of their intent to appeal. The other requirements of Section 1056(a) shall be submitted to the Board within 30 days after the Director's decision. The 30 days specified in section 1056.2 commence when the appeal statement meets the requirements of 1056(a).

1091.12 Emergency Departures from SYP

In the case of an Emergency as specified in the rules of the Board (14 CCR 1052.1), the SYP submitter shall notify the Director of such departure in writing and shall comply with Section 1091.13. This notice shall accompany any notice required by Section 1052 for cutting timber on an emergency basis. If an amendment to the SYP is required pursuant to Section 1091.13, it shall be filed within 20 days of the filing of the Emergency Notice. The SYP submitter shall comply with the Emergency Notice requirements.

CALIFORNIA FOREST PRACTICE RULES

1091.13 Amendments

Except under emergency circumstances, substantial deviations from the SYP shall not be undertaken in the THPs unless an amendment has been submitted to and approved by the Director following the same procedures as for approving an SYP initially. No THPs may be approved which rely upon a substantial deviation proposed in an amendment to a SYP until such a deviation is approved by the Director.

(a) Substantial Deviations. For purposes of the sustained timber production portion of any SYP, any deviation from the average harvesting projections in any ten-year period which exceeds ten percent, including a deviation caused by changes of ownership and catastrophic events, shall be considered a substantial deviation. For purposes of watershed and fish and wildlife issues, any deviation from the plan which could result in a significant change in timber operations and could result in significant adverse effects to watershed or fish and wildlife values shall be considered a substantial deviation.

(b) Minor deviations shall be reported to the Director immediately in writing but shall not require amendment of the plan.

1091.14 Timber Harvest Plans Submitted Within a SYP Management Unit

Each timber harvest plan submitted for an area within an ownership subject to and relying upon an approved SYP shall demonstrate consistency with the SYP and reference the SYP in response to THP questions addressing subjects covered in the SYP. Each THP shall contain feasible mitigation included in the SYP to address identified impacts. Responses to significant environmental issues raised during THP review on subjects addressed in the SYP shall refer to the SYP. Where new issues or potentially significant adverse effects not addressed in the SYP exist, they shall be identified in the THP or a substantial or minor deviation shall be submitted for the SYP as appropriate. Additional feasible mitigation measures to address new issues identified shall be discussed and included in the THP or amendment.

Article 6.8 Program EIR and THP

1092 Rule Application

(a) Where the abbreviation "THP", the term "Timber Harvesting Plan", or the word "plan" is used in Chapter 4, Subchapters 1 through 6 and Chapter 4.5 it shall also mean "PTHP". In Subchapter 7, this equivalency will occur for all sections except 1032 through 1042.

(b) Within 14 CCR Division 1.5, Chapter 4, Subchapters 4-6, Articles 2, 3, 4, 5, 6, 7, 8, 9, 11, 12, 13, and 14, the operational (specific prescriptive) standards of the rules shall apply to all timber operations conducted under a PTHP. However, as necessary for site-specific project level management, alternate standards can be developed which provide equal or better protection to the resource which may be impacted. These alternate standards may only be accepted by the Director when the PTEIR provides an analysis demonstrating that implementation will result in impacts which are below the level of significant effect on the environment as defined in the State CEQA Guidelines (14 CCR 15382) and other applicable state laws.

(c) Where the PTEIR has adequately addressed an environmental impact, the PTHP need only include reference to the PTEIR provisions. Alternate standards may only be used in a PTHP where the analysis of potential impacts and mitigations in the PTEIR is of such detail that a reasonable person could reach a conclusion that the resulting impacts would be less than significant.

(d) Within 14 CCR Division 1.5, Chapter 4, Subchapters 1, and 3-6, the planning (performance) standards which are to be incorporated into a THP under the functional equivalent process shall be addressed within the PTEIR to achieve the performance objectives set forth in the intent language of the regulation. The PTEIR shall demonstrate how resource protection set forth in the intent of the Act is provided for on the area encompassed by the PTEIR.

1092.1 PTEIR and PTHP

(a) A Program Timber Harvesting Plan (PTHP) may be filed for ownerships where a PTEIR has been certified by the Director.

(b) The PTEIR shall assess impacts and provide mitigation for those on and off-site impacts resulting from timber operations involved with an ownership, portion of an ownership, or multiple ownerships. Use of the PTEIR establishes the need for a separate THP process which is provided in this Article. The PTHP relies upon the environmental analysis contained in the PTEIR. All PTHPs shall be accompanied by a checklist which will

CALIFORNIA FOREST PRACTICE RULES

demonstrate that the proposed operations are within the scope of the PTEIR. The PTHP fulfills the requirements of CEQA by being written within the scope of the analysis contained in the PTEIR. The PTHP also must meet the requirements of the Forest Practice Act and the rules of the board.

(c) The checklist which accompanies a PTHP must be developed in each PTEIR to address the site specific impacts and practices for each ownership, portion of an ownership, or multiple ownerships. The checklist shall indicate mitigation to be applied in all areas of resource protection addressed in the PTEIR for individual and cumulative effects, including but not limited to air, wildlife, water, soil, recreation, hazard reduction, pest protection, noise, aesthetics, cultural resources, areas regulated by the board in Sections 4513, 4551, 4551.5, 4561, and 4581 of the Public Resources Code.

(d) Where a PTHP is found by the Director not to be within the scope of the PTEIR, the PTHP submitter has the following alternatives: 1) the PTHP may be modified to be within the scope of the PTEIR, 2) the PTHP may be withdrawn and submitted as a THP under the functional equivalent process, or 3) an addendum, supplement or subsequent PTEIR may be prepared and certified which addresses any remaining impacts identified in the PTHP.

(e) A PTHP shall be limited to an area with reasonably similar timber geology, soil, topography, climate, and stream characteristics that would constitute a logical harvesting unit. A PTHP should be limited to that area on which timber operations normally will be completed in one 12-month period, but in no case shall it extend beyond 36 months after the PTHP is determined to be in conformance or otherwise becomes effective under PRC 4582.7, unless an amendment to extend the effective period is submitted and accepted by the Department per PRC 4590(a)(1). PTHPs shall be limited to lands within a particular forest district.

1092.2 Director's Guidance for Review of PTEIR.

In certifying the PTEIR and adopting the CEQA findings the Director shall certify that the timberland management described in the PTEIR will achieve the resource protection goals in PRC Sections 4513, 4551, 4561, and 4581 and any goals that may be required by CEQA.

1092.3 Program Timber Harvesting Plan Filing Locations

The PTHP shall be submitted in writing to the Director at the appropriate Department of Forestry and Fire Protection offices listed in 14 CCR 1032.

1092.4 Program Timber Harvesting Plan (PTHP) Submittal

(a) A PTHP shall be submitted by the person who owns, leases, contracts, or operates on timberland and plans to harvest timber for commercial purposes.

(b) Where the land or timber is owned or operated by parties other than the person executing the PTHP the person submitting the PTHP shall give prompt written notice of such PTHP to those parties.

(c) The RPF preparing the PTHP shall submit to the Director, with the PTHP, a copy of a Notice of Intent to Harvest: (1) if any proposed boundary lies within 300 feet of any property not owned by the timberland owner, or (2) any PTHP amendment that changes a PTHP boundary so that the new boundary lies within 300 ft. of property not owned by the timberland owner.

(d) A Notice of Intent shall include the following information:

(1) The names of the timberland owner, the RPF who prepared the PTHP, and the PTHP submitter.

(2) The location of the PTHP area by county, section, township, and range, and the approximate direction and distance to the PTHP area from the nearest community or well-known landmark.

(3) The name of and distance from the nearest perennial watercourse flowing through or downstream from the PTHP area.

(4) The acres proposed to be harvested.

(5) The regeneration methods and intermediate treatments to be used.

(6) The estimated earliest date that the Director may approve the PTHP. This is 15 days from receipt of the PTHP by the Department, except in counties for which rules and regulations have been adopted pursuant to Section 4516.5 and 4516.8 of the PRC where the earliest date the Director may approve the PTHP is 45 days after the receipt of the PTHP by the Department.

(7) A statement that the public may review the PTHP at the appropriate Regional Office of CDF and that a copy of the PTHP may be obtained from the Department upon payment of the applicable charge.

(8) A map which provides the approximate boundary of the PTHP area, a map legend, and a scale.

CALIFORNIA FOREST PRACTICE RULES

(9) A statement that questions or concerns regarding the specific PTHP should be directed to the appropriate CDF Region or Area Office.

(e) The RPF preparing the PTHP shall furnish to the Department at the time of submission of the PTHP the names and mailing addresses of all property owners within 300 ft. of the PTHP boundary. Either a list compiled from the latest equalized assessment roll or a list provided by a title company doing business in California compiled within 60 days of submission of the PTHP shall be deemed sufficient for compliance with the subsection.

(f) The Department shall mail copies of the Notice of Intent within two working days of receipt of the PTHP to all persons identified in (e) above.

(g) Before PTHP submission, the person submitting the PTHP shall post a copy of the Notice of Intent including a map as described in (d)(8) at a conspicuous location on the public road nearest the PTHP site. The Notice shall be on colored paper or identified with colored flagging so as to be easily visible to the public.

(h) A statement of whether there is a known overhead electric power line on the proposed plan area except lines from transformers to service panels.

1092.5 Notice of Intent Distribution

The Director shall distribute copies of each Notice of Intent within two working days of receipt to:

(a) The office of the County Clerk of the county in which operations are proposed for posting at the customary place for posting environmental affairs.

(b) The local Ranger Unit headquarters for posting.

(c) At such other locations as the Director may deem desirable and feasible to provide adequate public notice.

1092.6 Request for Notification of PTHP Submission.

(a) Each Regional Office of the Department shall maintain a list of PTHPs submitted that month.

(b) When any person requests notice of submissions of PTHPs, the Director shall provide the person, free of charge, with a copy of the list of PTHPs submitted on the date or dates requested. If no specific date is requested, a copy of the list for the preceding month shall be provided.

1092.7 Request for Information on Domestic Water Supplies

The PTHP submitter shall provide notice by letter to all other landowners within 1,000 feet downstream of the PTHP boundary whose ownership adjoins or includes a Class I, II, or IV watercourse(s) which receives surface drainage from the proposed timber operations. The notice shall request that the PTHP submitter be advised of surface domestic water use from the watercourse, within the PTHP or within 1,000 feet downstream of the PTHP boundary. When required to notice by letter, the PTHP submitter shall also publish the notice one time in a newspaper of general circulation in the area affected by the proposed project. Such letter and publication shall notify the party of the proposed timber operation and describe its legal location and identify the name, if any, of the watercourse it may effect. The letter and publication shall request a response by the property owner within ten days of the post-marked date on the letter or the date of publication as appropriate. Copies of either notice, proof of service and publication, and any responses shall be attached to the PTHP when submitted. If domestic use is noted, the PTHP shall contain mitigations necessary to protect domestic water use. The PTHP shall not be submitted until ten days after the above notification(s) have been done. The RPF may propose, with justification and explanation, an exemption to such notification requirements, and the Director may agree.

1092.8 Filing Date

The filing date is the date on which the PTHP is found by the Director to be accurate, complete, and in proper order.

1092.9 PTHP Contents

The purpose of the PTHP is to provide guidance for implementation of the standards and protective measures in the certified PTEIR. For the PTHP to serve these functions it shall contain the following:

(a) Identification number of the PTEIR and where it can be reviewed;

CALIFORNIA FOREST PRACTICE RULES

(b) The name and address and phone number of the timberland owner, the timber owner, the RPF, the Licensed Timber Operator and license number and the person responsible for on the ground supervision of the timber operations. If the Licensed Timber Operator is not known at the time of plan submission, this information shall be provided prior to the start of timber operations.

(c) Expected dates of commencement and completion of timber operations.

(d) A legal description of the area of the PTHP on which timber operations will be conducted. The description shall include the following:

(1) U.S. Geological Survey (USGS) Quadrangle name(s) and date(s),

(2) township, range, and section number(s),

(3) county name(s),

(4) CALWATER 2.2 planning watershed number(s), and

(5) approximate acreage.

(e) Identification of silvicultural prescriptions to be applied.

(f) (1) A confidential Archaeological Addendum as defined in 895.1, if the PTHP covers 3.0 acres or more, or,

(2) A statement by the RPF that the area covered by the PTHP has been surveyed in accord with current Forest Practice Rules, and a Confidential Archaeological Addendum was filed and approved as part of the PTEIR associated with the PTHP, or the area covered by the PTHP is less than 3.0 acres.

(g) A statement that no significant adverse impacts would occur to any threatened or endangered plant or animal species in the area of the PTHP or that if timber operations are being conducted in compliance with an accepted "no take" or authorized incidental "take" procedure, either of which has authorization or concurrence of a wildlife agency acting within its authority under state or federal endangered species acts for a listed species, the PTHP shall so state.

(h) A statement that there have been no physical environmental changes in the PTHP area that are so significant as to require any addendum or supplement to the PTEIR;

(i) Special provisions, if any, to protect any unique area within the area of timber operations.

(j) A certification by the RPF that he or she or a supervised designee has personally inspected the PTHP area.

(k) A verification that the LTO has been briefed by the RPF or supervised designee on the contents and operational requirements of the PTHP prior to the start of timber operations.

(l) On a titled USGS quadrangle or equivalent topographic map of a scale not less than 2" to the mile, the information subsections (1-5) shall be clearly shown. Additional maps, which may be topographic or planimetric may be used to provide the information required in other subsections or show specific details, to improve map clarity. The appurtenant roads referenced in subsection (5) may be shown on a map which may be planimetric with a scale as small as one-half inch equals one mile. Color coding shall not be used. A legend shall be included indicating the meaning of the symbols used. See the district rules for the appropriate minimum mapping acreage.

(1) Boundaries of the area to be harvested.

(2) Boundaries of areas for specified regeneration methods, intermediate treatments, special harvesting methods, and alternative prescriptions that are to be applied.

(3) Boundaries of the Site Class of timberlands within the PTHP area.

(4) Boundaries of areas for specified yarding (logging) systems, if more than one system is to be used;

(5) Location of public roads within the PTHP, and private roads appurtenant to the timber operations where such roads are under the ownership or control of the timber owner, timberland owner or timber operator, and classification of all proposed and existing logging roads as permanent, seasonal, or temporary roads.

(6) Location of proposed and existing landings in the watercourse and lake protection zone, and landings outside the zone that are greater than 1/4 acre in size or whose construction involves substantial excavation.

(7) Road failures on existing roads to be reconstructed.

(8) Location of all watercourse crossings of classified watercourses except temporary crossings of class III watercourses without flowing water during timber operations at that crossing.

(9) Location of erosion hazard rating areas, if more than one rating exists.

CALIFORNIA FOREST PRACTICE RULES

(10) Location of watercourse with Class I, II, III or IV waters.

(11) Location of known unstable areas or slides.

Location of unique areas.

(m) Type of yarding (logging) systems and equipment to be used. Yarding systems will be placed in one or more of the following groups:

(1) Animal

(2) Tractor, skidder, forwarder

(3) Cable

(A) Ground-lead

(B) High-lead

(C) Skyline

(4) Balloon, helicopter

(5) Other, as explained in the PTHP

(n) A completed checklist from the certified PTEIR shall be attached to the PTHP and shall contain a listing of the practices which deviate from standard operational rules of the Board as presented in the PTEIR.

(o) Explanation and justification of any operational practices which are not specified in the certified PTEIR and which are allowed by the rules with explanation and justification.

(p) A certification by the RPF preparing the PTHP that the proposed operations are within the scope of the environmental analysis contained in the PTEIR as set forth in 14 CCR 1092 and therefore will not result in any significant environmental impacts beyond those addressed in the PTEIR.

1092.10 PTHP Professional Judgment

Where the rules or these regulations provide for the exercise of professional judgment by the RPF or the Director, and there is a disagreement the parties shall confer on the PTHP area, if requested by either party, during the PTHP review and reach agreement, if possible, on the conditions and standards to be included in the PTHP to maintain consistency with the PTEIR.

1092.11 PTHP Submitter Responsibility

The PTHP submitter, or successor in interest, shall:

(a) Ensure that an RPF conducts any activities which require an RPF.

(b) Provide the RPF preparing the PTHP or amendments with complete and correct information regarding pertinent legal rights to, interests in, and responsibilities for land, timber, and access as these affect the planning and conduct of timber operations.

(c) Sign the PTHP certifying knowledge of its contents and the requirements of this section.

(d) (1) Retain an RPF who is available to provide professional advice to the LTO and timberland owner upon request throughout the active timber operations regarding:

(A) the plan,

(B) the Forest Practice Rules, and

(C) other associated regulations pertaining to timber operations.

(2) The plan submitter may waive the requirement to retain an RPF to provide professional advice to the LTO and timberland owner under the following conditions:

(A) the plan submitter provides authorization to the timberland owner to provide advice to the LTO on a continuing basis throughout the active timber operations provided that the timberland owner is a natural person who personally performs the services of a professional forester and such services are personally performed on lands owned by the timberland owner;

(B) the timberland owner agrees to be present on the logging area at a sufficient frequency to know the progress of operations and advise the LTO, but not less than once during the life of the plan; and

(C) the plan submitter agrees to provide a copy of the portions of the approved PTHP and any approved operational amendments to the timberland owner containing the General Information, Plan of Operations, PTHP Map, Yarding System Map, Erosion Hazard Rating Map and any other information deemed by the timberland owner to be necessary for providing advice to the LTO regarding timber operations.

All agreements and authorizations required under 14 CCR § 1035(d)(2) shall be documented and provided in writing to the Director to be included in the plan.

CALIFORNIA FOREST PRACTICE RULES

(e) Within five (5) working days of change in RPF responsibilities for PTHP implementation or substitution of another RPF, file with the Director a notice which states the RPF's name and registration number, address, and subsequent responsibilities for any RPF required field work, amendment preparation, or operation supervision. Corporations need not file notification because the RPF of record on each document is the responsible person.

(f) Provide a copy of the approved PTHP and any amendments to the LTO.

(g) Notify the Director prior to commencement of site preparation operations. Receipt of a burning permit is sufficient notice.

(h) Disclose to the LTO, prior to the start of operations, through an on-the-ground meeting, the location and protection measures for any archaeological or historical sites requiring protection if the RPF has submitted written notification to the plan submitter that the plan submitter needs to provide the LTO with this information.

1092.12 Registered Professional Forester Responsibility

(a) Upon submission of a PTHP, the RPF who prepares and signs a PTHP is responsible for the accuracy and completeness of its contents.

(b) The RPF preparing the PTHP shall list or describe in the PTHP any work which will be performed by the PTHP preparer and any additional work requiring an RPF which the PTHP preparer does not intend to perform. This may include, but is not limited to, field work in identifying watercourse and lake protection zones or special treatment areas, marking trees, or other activities. The RPF is only responsible for the activities for which he or she is employed, or those required by the rules of the Board. The RPF shall state whether or not he or she has been retained to provide professional advice throughout the timber operations.

(c) The RPF preparing the PTHP shall, in writing, inform the PTHP submitter(s) of their responsibility pursuant to Section 1092.11 of this Article and the timberland owner(s) of their responsibility for compliance with the requirements of the Act and, where applicable, Board rules regarding site preparation, stocking, and maintenance of roads, landings, and erosion control facilities.

(d) Upon entering into an agreement to accept responsibility for any part of the preparation or implementation of a plan or any work beyond the preparation of a plan, including providing professional advice; all responsible RPFs shall disclose to the real party of interest for whom the RPF is providing professional forestry services any known current or potential conflict of interest the RPFs have with regard to the timber or land that is subject to operations under the plan. All responsible RPFs shall disclose to the timberland owner and plan submitter whether they are the real party of interest for whom the RPF is providing professional forestry services.

(e) Disclosure of newly discovered conflicts of interest an RPF has with regard to the plan submitter, timberland owner, timber owner, the LTO and timber purchaser, pertaining to the timber or land that is subject to operations under the plan, shall be required as long as an RPF has responsibilities relative to a plan. The disclosure shall include identification of the real party of interest for whom the RPF is providing professional forestry services.

(f) All disclosures made between an RPF and an affected party pursuant to this section may be kept confidential.

(g) An RPF retained by the plan submitter to provide professional advice throughout the timber operations shall be present, or ensure that the RPF's supervised designee is present, on the logging area at a sufficient frequency to know the progress of operations and advise the LTO and timberland owner, but not less than once during the life of the plan.

(h) An RPF retained by the plan submitter to provide professional advice throughout the timber operations shall inform the LTO during operations of any mitigation measures incorporated into the plan that are intended to address operations that have a high likelihood of resulting in immediate, significant and long-term harm to the natural resources of the State if such mitigation measures are not strictly applied to minimize such impacts.

(i) The RPF shall without delay notify in writing the LTO, the plan submitter, and the Department of a decision to withdraw professional services from the plan.

CALIFORNIA FOREST PRACTICE RULES

1092.13 Interaction Between RPF and LTO on the PTHP

From the start of the PTHP preparation process but before commencement of operations, the responsible RPF, shall meet with either the LTO, or supervised designee who will be on the ground and directly responsible for the harvesting operation. The meeting shall be on site if requested by either the RPF or LTO. If any amendment is incorporated into the PTHP by an RPF after the first meeting, the RPF shall comply with the intent of this section by explaining relevant changes to the LTO; if requested by either the RPF or LTO, another on-site meeting shall take place. The intent of any such meeting is to assure that the LTO:

- (a) Is advised of any sensitive on-site conditions requiring special care during operations.
- (b) Is advised regarding the intent and applicable provisions of the approved PTHP including amendments.

1092.14 Licensed Timber Operator Responsibilities

Each affected Licensed Timber Operator shall:

(a) Sign the plan and major amendments to the plan, or sign and file with the Director a facsimile of such plan or amendments, agreeing to abide by the terms and specifications of the plan. This shall be accomplished prior to implementation of the following; which the affected LTO has responsibility for implementing:

- 1) those operations listed under the plan and
- 2) those operations listed under any amendments proposing substantial deviations from the plan.

(b) Inform the responsible RPF and PTHP submitter, either in writing or orally, of any site conditions which in the LTO's opinion prevent implementation of the PTHP.

(c) Be responsible for the work of his or her employees and familiarize all employees with the intent and details of the operational land protection measures of the PTHP and amendments or minor deviations that apply to their work.

(d) Keep a copy of the applicable approved PTHP and amendments available for reference at the site of active timber operations. The LTO is not required to possess any confidential addenda to the plan such as the Confidential Archaeological Addendum, nor is the LTO required to keep a copy of such confidential plan addenda at the site of active timber operations.

(e) Comply with all provisions of the Act, Board rules and regulations, the applicable PTHP and any approved amendments or minor deviations.

(f) In the event that the LTO executing the plan was not available to attend the on-site meeting to discuss archaeological site protection with the RPF or supervised designee familiar with on-site conditions pursuant to Section 929.2 [949.2, 969.2] (b), it shall be the responsibility of the LTO executing the plan to inquire with the plan submitter, timberland owner, or their authorized agent, RPF who wrote the plan, or the supervised designee familiar with on-site conditions, in order to determine if any mitigation measures or specific operating instructions are contained in the Confidential Archaeological Addendum or any other confidential addendum to the plan.

(g) Provide the RPF responsible for professional advice throughout the timber operations an on-site contact employee authorized by the LTO to receive RPF advice.

(h) Keep the RPF responsible for professional advice throughout the timber operations advised of the status of timber operation activity.

(1) Within five days before, and not later than the day of the start-up of a timber operation, the LTO shall notify the RPF of the start of timber operations.

(2) Within five days before, and not later than the day of the shutdown of a timber operation, the LTO shall notify the RPF of the shutdown of timber operations.

(A) The notification of the shutdown of timber operations is not required if the period of the shutdown does not extend beyond a weekend, including a nationally designated legal holiday.

(i) Upon receipt of written notice of an RPF's decision to withdraw professional services from the plan, the LTO or on-site contact employee shall cease timber operations, except for emergencies and operations needed to protect water quality, until the LTO has received written notice from the plan submitter that another RPF has visited the plan site and accepts responsibility for providing advice regarding the plan as the RPF of record.

CALIFORNIA FOREST PRACTICE RULES

1092.15 Notification of Commencement of Operations

For each calendar year, within fifteen days before, and not later than the day of the start up of a timber operation, the PTHP Submitter, or designee shall notify CDF of the start of timber operations. The notification, by telephone or by mail, shall be directed to the appropriate CDF Ranger Unit Headquarters, Forest Practice Inspector, or other designated personnel.

1092.16 PTHP Review Inspection-Filing Return

Within ten (10) days of the receipt of a PTHP, the Director shall determine if the PTHP is accurate, complete and in proper order, and if so, the PTHP shall be filed. During this same period, the Director shall determine if a preharvest inspection is necessary. If a preharvest inspection is needed, the Department will notify the submitter, the Department of Fish and Game, the Department of Conservation, Division of Mines and Geology, the appropriate California Regional Water Quality Control Board, and the LTO who will operate under the plan, if known, to determine if they want to attend and to schedule a mutually agreeable time and date of the inspection. When the Director finds a PTHP inaccurate, incomplete, or otherwise not in proper order, the PTHP shall be returned to the submitter with written specifications of the deficiencies.

1092.17 Notice of PTHP Filing

(a) The Director shall prepare a notice of filing which shall contain the basic information contained in the Notice of Intent (14 CCR 1092.04).

(b) Within two working days of the date the PTHP is filed, the Director shall transmit copies of the Notice of Filing to:

- (1) The person submitting the PTHP.
- (2) The office of the County Clerk of the county in which the operations are proposed. The notice shall be posted at the normal place for posting environmental notices.
- (3) The local Ranger Unit headquarters for posting.
- (4) At such other locations as the Director may deem desirable and feasible to provide adequate public notice.
- (5) All public agencies having custodial responsibility for lands within 300 ft. of the PTHP boundary.
- (6) Anyone else, as required by Public Resources Code 4582.4 and 4582.6.

1092.18 Agency and public Review for the PTHP

(a) Upon filing a PTHP in accordance with 14 CCR 1092.16 the Director shall place it, or a true copy thereof, in a file available for public inspection, and shall transmit a copy to the Department of Fish and Game, the appropriate California Regional Water Quality Control Board, the Department of Conservation, Division of Mines and Geology, the Department of Parks and Recreation, the county planning agency and, if the areas are within their jurisdiction, to the California Tahoe Regional Planning Agency and the California Coastal Commission.

(b) The Director shall also transmit a copy of any specific PTHP to any person who has made a written request.

(c) The Department shall bill such persons for the cost of providing such copies and such monies shall be paid to the Department.

The Director shall invite written comments, and will consider these comments. All comments should address any areas where there is a question of consistency with the PTEIR, the Act, the applicable rules of the Board and any other applicable legal requirements. All comments shall be in writing and shall be addressed to the Director at the regional office where the PTHP was filed.

1092.19 Time Periods for Review

The Director shall have 15 days from the date the preharvest or initial inspection is completed, or in the event the Director determines that such inspection is not needed, 15 days from the date of PTHP filing in accordance with 14 CCR 1092.16 or such longer period as may be mutually agreed upon by the Director and the person submitting the PTHP, to review the PTHP and to take written comment.

CALIFORNIA FOREST PRACTICE RULES

After the public review period has ended the Director shall have up to ten working days, or a longer period mutually agreed upon by the Director and the person submitting the PTHP, to review the public and agency comments, to respond in writing to issues regarding the conformance of the PTHP to the PTEIR and compliance with the rules of the board and to determine if the PTHP is in conformance with the PTEIR, Forest Practice Act and Board rules.

1092.20 Director's guidance for review of PTHP

(a) In reviewing a PTHP the Director shall determine if the PTHP is in compliance with the rules of the board specified in 14 CCR Article 6.8 and whether the proposed activity is within the scope of the PTEIR, and that the PTEIR adequately describes the proposed activity for the purposes of CEQA.

(b) In determining if a PTHP is within the scope of the PTEIR the Director shall determine if one or more of the following conditions exist which requires action under 14 CCR 1092.01(d):

(1) Where activities are proposed in the PTHP that could result in significant environmental impacts not considered in the PTEIR.

(2) Where substantial changes have occurred with respect to the circumstances under which the PTHP is undertaken that could result in significant environmental impacts not previously covered; or

(3) Where new relevant information regarding impacts or mitigation measures becomes available that shows any of the following:

A) the PTHP would have one or more significant effects not disclosed in the PTEIR.

B) effects previously examined would be substantially more intensive or extensive than shown in the PTEIR.

C) mitigation measures or alternatives previously determined to substantially reduce one or more significant impacts but found to be infeasible would in fact be feasible, or

D) feasible mitigation measures or alternatives not previously considered in the PTEIR were identified that would substantially reduce one or more significant effects.

1092.21 Special Conditions Requiring Disapproval of a PTHP

The Director shall disapprove a PTHP as not conforming to the rules of the Board if any one of the following conditions exist:

(a) Boundaries of the area to be harvested are not clearly delineated in the PTHP.

(b) Public acquisition of the parcel for purposes which would be impaired by timber harvesting, is legislatively authorized, funded and imminent,

(c) There is evidence that the information contained in the PTHP is incorrect, incomplete or misleading in a material way, or is insufficient to evaluate significant environmental effects. The sufficiency of the information provided in a PTHP to evaluate significant environmental effects shall be judged in light of what is reasonable and necessary.

(d) Implementation of the PTHP as proposed would result in either a "taking" or finding of jeopardy of species listed as rare, threatened or endangered under the state or federal Endangered Species Acts, or would cause significant, long-term damage to listed species. The Director is not required to disapprove a plan if incidental "take" is authorized by a wildlife agency acting within its authority under state or federal endangered species acts.

1092.22 Nonconformance of PTHP

If the Director determines that a PTHP is not within the scope of the PTEIR or is not in conformance with the applicable rules of the Board the PTHP shall be returned in accordance with 14 CCR 1054. In addition, the Director shall state any changes and reasonable conditions that in the Director's professional judgment are needed to bring the PTHP within the scope of the PTEIR or into conformance with the applicable rules of the Board and offer to confer with the RPF in order to reach agreement on the conditions necessary to bring the PTHP into conformance.

1092.23 Conformance of PTHP

If the Director determines that the PTHP is within the scope of the PTEIR and is in conformance with the Forest Practice Act and applicable rules of the Board, then the person submitting the PTHP shall be notified and timber operations may commence.

CALIFORNIA FOREST PRACTICE RULES

1092.24 Notice of Conformance of the PTHP

Within ten working days of the date a PTHP is found in conformance, the Director shall transmit a notice thereof to the agencies and persons referred to in 14 CCR 1092.18 and for posting at the places named in 14 CCR 1092.17. A copy of the notice shall be filed with the Secretary for Resources. The notice of conformance shall include a written response of the Director to questions of consistency with the PTEIR raised during the evaluation process and shall also contain the following statements:

- (a) The proposed activity is within the scope of the PTEIR, and
- (b) The PTEIR adequately describes the environmental effects of the activity for the purposes of CEQA.

1092.25 Public Inspection

Notices of Conformance, pursuant to 14 CCR 1092.24 and notices of approval by the Board, pursuant to 14 CCR 1054.8, shall be available for public inspection, and a list of such notices shall be posted on a weekly basis in the Resources Agency office. Each such list shall remain posted for a period of 30 days.

1092.26 Amendment

Changes that are not “minor deviations” as defined in 14 CCR 895.1 are presumed to be substantial deviations if they potentially could have a significant adverse affect on timber productivity or values relating to soil, water quality, watershed, wildlife, fisheries, range and forage, recreation and aesthetic enjoyment that are beyond impacts identified in the PTEIR. Such actions may include, but are not limited to:

- (a) Change in location of timber harvesting operations or enlargement of the area to be cut.
- (b) Change in the silvicultural method and cutting system on any portion of the PTHP area.
- (c) Change in type or location of logging (yarding) system or basic type of equipment.
- (d) Change in location, nature or increase in length of proposed logging roads incorporating one or more

of the following criteria:

- (1) Any road in the Watercourse and Lake Protection Zone or where sidecast will extend into the Watercourse and Lake Protection Zone.
- (2) Any road located in an extreme Erosion Hazard Rating area in the Coast Forest District, extreme Estimated Erosion Potential area in the Northern Forest District, or a high Erosion Potential area in the Southern Forest District.
- (3) Any road where the average side slope exceeds 50%.
- (4) Any road where unstable areas, active soil movement, or slide areas must be traversed.
- (5) Any increase in gradient allowed by the District Rules as an exception and not provided for in the original PTHP.
- (6) Any road extension of more than 600 feet (182.9 m).
- (e) Any use of existing roads not shown in the original PTHP when reconstruction work to allow for vehicle travel will be substantial. Substantial work on an existing road means more than minor repair and dressing of the travel surface and removal of vegetation to allow for vehicle passage.
- (f) Enlargement of landings where such enlargement was not justified in the original PTHP.
- (g) Any change of operation in, or designation of, the Watercourse and Lake Protection Zone.
- (h) Any downgrading of stream classification.
- (i) A change to winter operation where summer operations was previously specified.
- (j) Amendments proposing timber operations in a PTHP which would place the PTHP outside the scope of the PTEIR must be considered under 14 CCR 1092.01 (d).
- (k) Substantial deviations shall not be undertaken until such amendment has been filed and approved by the Director as required by this Article for the original PTHP.

1092.27 Report Minor Deviations

(a) Minor deviations as described in 14 CCR 895.1 shall be submitted in writing to the Director before undertaking the deviation. Actions described in 14 CCR 1092.26 which are normally presumed to be substantial deviations may, in a given instance, be minor deviations. Actions listed as substantial deviations in 14 CCR 1092.26 or discussed in the PTEIR that are considered to be minor by the submitter may be undertaken only if requested in writing to and approved by the Director.

CALIFORNIA FOREST PRACTICE RULES

(b) The Director shall have five working days to determine if the proposed deviation is substantial or minor. Upon the date of receipt, the Director shall send copies of the proposed deviation to the Department of Fish and Game, the California Regional Water Quality Control Board, the Department of Conservation, Division of Mines and Geology, and any County which has special rules adopted under Section 4516.5 of the Public Resources Code.

(c) Where the Director fails to act within the five day period or a determination is made that the proposed deviation is minor, work may commence.

(d) Where the Director determines the proposed deviation is substantial, the review process in 14 CCR 1092.18 will be followed.

1092.28 Effective Period of the PTHP and PTEIR.

(a) The effective period of the PTHP within the meaning of PRC 4590 and 4591 is the 3 year period following the date the PTHP is determined to be in conformance or otherwise becomes effective pursuant to 4582.7. Timber operations shall commence no earlier than the expected date of commencement stated in the PTHP and shall be completed no later than the expected date of completion stated in the PTHP except under the following conditions:

(1) An amendment to change the completion date stated in a PTHP has been submitted to the Director at least ten days before the expected date of completion.

(2) An amendment to extend the effective period of a PTHP beyond three years is submitted in compliance with PRC 4590 which includes a map showing clearly the area pertinent to the request for extension.

(b) Upon receipt of such amendment, the Director shall determine whether the change in date constitutes a substantial deviation of the PTHP. An extension of time is presumed to be a minor deviation, provided the extension does not lead to practices that constitute a substantial deviation, as defined Section 1092.26. If the Director determines that such a change of date is a substantial deviation, then the PTHP extension shall not be approved.

(c) The PTEIR will be effective until such time as substantial changes in conditions occur or significant environmental impacts are identified which are not addressed in the PTEIR. When this occurs the PTEIR may be amended or supplemented to address such new information. Alternatively, PTHP's may be modified to fall within the scope of the PTEIR.

1092.29 Change of Ownership

(a) Any land ownership change upon which there is an unapproved work completion report or stocking report, must be reported to the Director.

(b) Prior to recordation, the existing PTHP timberland owner shall notify the acquiring timberland owner of the existence of the PTHP, the requirement to notify the Director of the change of ownership, and the acquiring party's responsibility for compliance with the stocking standards of the Act and the applicable rules of the Board.

(c) The acquiring party shall notify the Director within 10 days of the date title is recorded by the county recorder.

1092.30 Cancellation of PTHP

All parties who submitted the PTHP, or their successors, must sign the request to the Director for cancellation of a PTHP. Once cutting has commenced, the PTHP may not be canceled except as to lands not harvested.

1092.31 Appeals

Appeals of PTHPs shall be the same as provided for in the FPA for THPs. For Head of Agency Appeals, the appealing agency shall have ten days from the Director's determination date to notify the Board of their intent to appeal. The other requirements of Section 1056(a) shall be submitted to the Board within 30 days after the Director's decision. The 30 days specified in Section 1056.2 commence when the appeal statement meets the requirements of 1056(a).

CALIFORNIA FOREST PRACTICE RULES

1092.32 Interim Measures for Maximum Sustained Production of High Quality Timber Products

Timberland ownership's of 50,000 acres or more may use subsection (c) of Sections 913.11, 933.11, and 953.11 if a Notice of Preparation for a PTEIR has been filed with the Department. This option may only be used until the PTEIR is certified or rejected by the Department. Maximum Sustained Production will be maintained under the provisions of the PTEIR after certification of the PTEIR by the Department.

Article 7 Conversion of Timberland

1100 Definitions

The following are definitions of words and terms as used in this article:

(a) "Alternate Use or Alternative Use" a proposed land use that is not a compatible use within a timberland production zone (Ref.: Sec. 51134(b), Gov. C.).

(b) "Bona Fide Intention or bona fide intent" a present, sincere intention of the applicant to conform with and successfully execute the conversion plan, as determined by the Director in accordance with provisions of Sec. 1105.2 (Ref.: Sec. 4623, PRC).

(c) "Coastal Commercial Timberlands" timberland as defined in PRC 4526, for those lands which lie within the coastal zone and outside a timberland production zone; or as defined in Gov. C. 51100(f) for those lands which lie within both the coastal zone and a timberland production zone (Ref.: Sec. 4526 and 30243, PRC; Sec. 51100 (f), Gov. C.).

(d) "Coastal Zone" those lands defined in PRC 30103. (Ref.: Sec. 30103, PRC).

(e) "Compatible Use" compatible use as defined in Gov. C. 51100 (h) and 51111, as made specific by county or city ordinance adopted pursuant thereto (Ref.: Sec. 51100 (h) and 51111, Gov. C.).

(f) "Contiguous" two or more parcels of land that are adjoining or neighboring or are sufficiently near to each other, as determined by the County Board of Supervisors or City Council, that they are manageable as a single forest unit (Ref.: Section 51100 (b), Government Code.)

(g) "Timberland Conversion":

(1) Within non-Timberland Production Zone (TPZ) timberland, transforming timberland to a nontimber growing use through timber operations where:

(A) Future timber harvests will be prevented or infeasible because of land occupancy and activities thereon; or

(B) Stocking requirements of the applicable district forest practice rules will not be met within five years after completion of timber operations; or

(C) There is a clear intent to divide timberland into ownerships of less than three acres (1.214 ha.).

(2) Within TPZ lands, the immediate rezoning of TPZ lands, whether timber operations are involved or not except as exempt from a timberland conversion permit under 14 CCR 1104.1.

(h) "Conversion Permit" the timberland conversion permit, issued by the Director or the Board upon appeal, approving the application for timberland conversion and authorizing a conversion of timberland to use or uses other than the growing of timber (Ref.: Sec. 4622, 4624, 4624.5 and 4625, PRC).

(i) "Government Agency" the State or any department, agency, or public body thereof, a city or county, public corporation, municipal corporation, or public district (Ref.: Sec. 21062 and 21063, PRC).

(j) "Immediate Rezoning" a change in zoning for land use by the appropriate county or city having jurisdiction of an area within a TPZ to allow an alternative use pursuant to Article 4 (commencing with Sec. 51130) of Chapter 6.7, Part 1, Division 1, Title 5 of the Gov. C. (Ref.: Sec. 4526, PRC; Sec. 51104(f), Gov. C.; Sec. 1021, Title 14, CCR).

(k) "Land Parcel" means a piece of land under one ownership where no part is completely separated from any other part by a different fee ownership.

(l) "Parcel" parcel as defined in Sec. 51104(i) of the Gov. C.

(m) "Timberland" timberland as defined in PRC 4526, for land outside a TPZ. Timberland as defined in Gov. C. 51100(f), for land within a timberland production zone (Ref.: Sec. 4526, PRC; Sec. 51100(f), Gov. C.).

(n) "Timberland Production Zone or TPZ" timberland production zone as defined in Gov. C. 51104(g) (Ref.: Sec. 51104(g), Gov. C.).

CALIFORNIA FOREST PRACTICE RULES

1101 Purpose

The purpose of these regulations is to interpret and make specific certain provisions of the Z'berg-Nejedly Forest Practice Act of 1973, contained in Chapter 8 (commencing with Section 4511) of Part 2, Division 4 of the PRC; the Environmental Quality Act of 1970, contained in Division 13 (commencing with Section 21000) of the PRC; portions of the Z'berg-Warren-Keene-Collier Forest Taxation Reform Act of 1976 (Chapter 176, California Statutes of 1976), contained in Chapter 67 (commencing with Section 51100) or Part 1, Division 1, Title 5 of the Gov. C.; the California Coastal Act of 1976, contained in Division 20 (commencing with Sec. 30000) of the PRC; and the Public Records Act contained in Chapter 3.5 (commencing with Sec. 6250) of Division 7, Title 1 of the Government Code. These regulations pertain to the conversion of certain timber-growing lands to a use or uses other than the growing of timber.

1102 Authority Delegated to Director

The Board delegates its authority and responsibilities to the Director for administration of Article 9 (commencing with Sec. 4621) of Chapter 8, Part 2, Division 4 of the PRC, and Article 4 (commencing with Sec. 51130) of Chapter 6.7, Part 1, Division 1, Title 5 of the Gov. C., and the administrative regulations adopted pursuant to each of the above cited authorities, except that all hearings thereunder shall be before the Board.

1103 Conversion of Timberland

Any person, firm, corporation, company, partnership or government agency owning timberland for which the timberland owner proposes conversion as defined in Section 1102 shall apply to the Director on a form prescribed by him for issuance of a Timberland Conversion Permit.

1103.1 Prohibited Activity

(a) No timber operations or other conversion activities shall be conducted on timberland which is proposed to be converted to a use other than the growing of timber unless a conversion permit has been issued by the Director or the Board upon appeal and the permit has been recorded in compliance with 14 CCR [1106.3](a).

(b) No timber operations shall be conducted on timberland for which a conversion permit has been issued until a Timber Harvesting Plan has been filed with and found in conformance by, the Director in accordance with Article 7 (commencing with Sec. 4581) of Chapter 8, Part 2, Division 4 of the PRC and the rules and regulations of the Board issued pursuant thereto.

(c) The timberland owner shall provide each timber operator copies of both the recorded conversion permit, and recorded amendments thereto, and the approved THP. Copies of said documents shall be conveniently available for inspection at all times during timber operations conducted pursuant to said conversion permit.

1103.2 Public Records

All applications, forms, documents, correspondence, maps, photographs, and other materials submitted to the Director or Board relating to an application for conversion are public records pursuant to the provisions of the Public Records Act, contained in Chapter 3.5 (concerning with Sec. 6250) of Division 7, Title 1 of the Gov. C.

1104 Operations Requiring Conversion Permit

Except as exempted by Sec. 1104.1 and 1104.2 of this article a timberland conversion permit issued by the Director is required for conversion of timberland as defined in Sec. 1100. Issuance of the Timberland Conversion Permit to the timberland owner must be completed before conversion operations begin. "Conversion operations" include final immediate rezoning of timberland production zone lands, and timber operations as defined in PRC 4527 on nontimberland production zone timberlands.

1104.1 Conversion Exemptions

Timber operations conducted under this subsection shall be exempt from conversion permit and timber harvesting plan requirements of this article except no tree that existed before 1800 A.D and is greater than sixty (60) inches in diameter at stump height for Sierra or Coastal Redwoods, and forty-eight (48) inches in

CALIFORNIA FOREST PRACTICE RULES

diameter at stump height for all other tree species shall be harvested unless done so under the conditions or criteria set forth in subsection 1104.1 (i).

Timber operations shall comply with all other applicable provisions of the Z'berg-Nejedly Forest Practice Act, regulations of the Board and currently effective provisions of county general plans, zoning ordinances and any implementing ordinances. The Notice of Conversion Exemption Timber Operations shall be considered synonymous with the term "plan" as defined in 14 CCR 895.1 when applying the operational rules and regulations of the Board.

(a) This conversion exemption is applicable to a conversion of timberland to a non-timber use only, of less than three acres in one contiguous ownership, whether or not it is a portion of a larger land parcel and shall not be part of a THP. This conversion exemption may only be used once per contiguous land ownership.

(1) A Notice of Conversion Exemption Timber Operations must be prepared by an RPF and submitted to the Director. The notice shall contain the following:

(A) The names, addresses, and telephone numbers of the timber owner, owner of the timberland to be converted, RPF, timber operator, and the submitter of the Notice of Conversion Exemption Timber Operations;

(B) Legal description of the area where the timber operation is to be conducted, showing section, township, range, county and assessor parcel number;

(C) Maps showing the ownership boundaries, the location of the timber operation, boundaries of the conversion, access routes to operation, location and classification of all watercourses, and landing locations;

(D) Incorporation of a signed and dated statement from the authorized designee of the County Board of Supervisors stating that the conversion is in conformance with all county regulatory requirements, including county public notice requirements. When counties do not have an authorized designee, the RPF shall certify that the county has been contacted and the conversion is in conformance with county regulatory requirements (this may be incorporated into the notice);

(E) Incorporation of a statement by the owner of the timberland to be converted, certifying that this is a one-time conversion to non-timberland use, that there is a "bona fide intent", as defined in CCR 1100 (b), to convert and specifying what the non-timberland use will be after conversion; and

(F) signature of the submitter, timberland owner responsible for the conversion, the timber operator, and the RPF.

(2) The following conditions apply to conversion exemption timber operations:

(A) All timber operations shall be complete within one year from the date of acceptance by the Director.

(B) All conversion activities shall be complete within two years from the date of acceptance by the Director unless under permit by local jurisdiction. Failure to timely complete the conversion shall require compliance with stocking standards of the PRC 4561 and stocking report requirements of Forest Practice Act and Board regulations.

(C) The RPF or supervised designee shall visit the site and flag the boundary of the conversion exemption timber operation and flag any applicable WLPZs and equipment limitation zones.

(D) This section refers to slash and woody debris resulting from timber operations associated with conversion exemptions. The timber operator shall be the responsible party for the treatment of logging slash and woody debris. Responsibility for treatment of logging slash and woody debris may be assumed by the landowner, provided that the landowner acknowledges in writing to the Director at the time of notice such responsibility and specific slash and woody debris treatment requirements and timing.

(1) Unless otherwise required, slash greater than one inch in diameter and greater than two feet long, and woody debris, except pine, shall receive full treatment no later than April 1 of the year following its creation, or within one year from the date of acceptance of the conversion exemption by the Director, whichever comes first.

(2) All pine slash three inches and greater in diameter and longer than four feet must receive initial treatment if it is still on the parcel, within 7 days of its creation.

(3) All pine woody debris longer than four feet must receive an initial treatment prior to full treatment.

(4) Initial treatment shall include limbing woody debris and cutting slash and woody debris into lengths of less than four feet, and leaving the pieces exposed to solar radiation to aid in

CALIFORNIA FOREST PRACTICE RULES

rapid drying.

(5) Full treatment of all pine slash and woody debris must be completed by March 1 of the year following its creation, or within one year from the date of acceptance of the conversion exemption by the Director, whichever comes first.

(6) Full slash and woody debris treatment may include any of the following:

- a. burying;
- b. chipping and spreading;
- c. piling and burning; or
- d. removing slash and woody debris from the site for treatment in

compliance with (a)-(b).

Slash and woody debris may not be burned by open outdoor fires except under permit from the appropriate fire protection agency, if required, the local air pollution control district or air quality management district. The burning must occur on the property where the slash and woody debris originated.

(7) Slash and woody debris, except for pine, which is cut up for firewood shall be cut to lengths 24 inches or less and set aside for drying by April 1 of the year following its creation. Pine slash and woody debris which is cut up for firewood shall be cut to lengths 24 inches or less and set aside for drying within seven days of its creation.

All treatment work must be completed prior to the expiration date for the conversion exemption.

(8) Any treatment which involves burning of slash or woody debris shall comply with all state and local fire and air quality rules.

(9) This section does not supersede more restrictive treatments or time frames within a Forest district or subdistrict.

(E) Timber operations may be conducted during the winter period. Tractor operations in the winter period are allowed under any of the following conditions:

1. During dry, rainless periods where saturated soils conditions, as defined in 14 CCR 895.1, are not present. Erosion control structures shall be installed on all constructed skid trails and tractor roads prior to sunset if the National Weather Service forecast is a "chance" (30% or more) of rain within the next 24 hours.

2. When ground conditions in the conversion exemption area and appurtenant roads satisfy the "hard frozen" definition in 14 CCR 895.1.

3. Over-snow operations where no soil disturbance occurs.

(F) No timber operations within a WLPZ unless specifically approved by local permit (e.g. County, City).

(G) The timber operator shall not conduct timber operations until receipt of the Director's notice of acceptance. Timber Operations shall not be conducted without a valid on-site copy of the Director's notice of acceptance of operations and a copy of the Notice of Conversion Exemption Timber Operations as filed with the Director.

(H) No sites of rare, threatened or endangered plants or animals shall be disturbed, threatened or damaged and no timber operations shall occur within the buffer zone of a sensitive species as defined in 14 CCR 895.1.

(I) No timber operations on significant historical or archeological sites.

(J) The RPF and the timber operator shall meet (on-site, or off-site) if requested by either party to ensure that sensitive on-site conditions and the intent of the conversion regulations such as, but not limited to, slash disposal, will be complied with during the conduct of timber operations.

(3) A neighborhood notification of conversion exemption timber operations shall be posted on the ownership visible to the public by the RPF or supervised designee, at least 5 days prior to the postmark date of submission of the notice of Conversion Exemption Timber Operations to the Director. The date of posting shall be shown on the neighborhood notice. In addition, immediately prior to the submission of the exemption to the Director, the landowner shall mail a letter to adjacent landowners within 300 feet of the boundaries of the exemption, and to Native Americans, as defined in 895.1 notifying them of the intent to harvest timber. The mailed letter of notice and the posted notice shall contain the following information on a form prepared by the RPF:

CALIFORNIA FOREST PRACTICE RULES

(A) the name, address and telephone number of the timberland owner, the timber operator, the agency of the county responsible for land use changes and the designated representative; if any, and the RPF;

(B) the location of the project, parcel number, street address, section, township and range, and;

(C) a statement explaining that this is a conversion from timberland use to a new land use, what the new land use will be, and that the maximum size is less than three acres.

(4) The Director shall determine if the Notice of Conversion Exemption Timber Operations is complete and accurate within fifteen days from the date of receipt.

(A) If the Notice of Conversion Exemption Timber Operations is not complete and accurate it shall be returned to the submitter identifying the specific information required. When found complete and accurate, the Director shall immediately send a notice of acceptance of operations to the submitter.

(5) The timberland owner shall, within one month from the completion of conversion exemption timber operations, which includes all slash disposal work, submit a work completion report to the Director.

(b) Construction or maintenance of right-of-way by a public agency on its own or any other public property.

(c) The clearing of trees from timberland by a private or public utility for construction of gas, water, sewer, oil, electric, and communications (transmitted by wire, television, radio, or microwave) rights-of-way, and for maintenance and repair of the utility and right-of-way. The said right-of-way, however, shall not exceed the width specified in the Table of Normal Rights-of-Way Widths for Single Overhead Facilities and Single Underground Facilities and the supplemental allowable widths.

Nothing in this section shall exclude the applicable provisions of PRC 4292 and 4293, and 14 CCR 1250 through 1258 inclusive for fire hazard clearance from being an allowable supplement to the exempt widths.

(d) TABLE OF RIGHTS-OF-WAY WIDTHS FOR SINGLE OVERHEAD FACILITIES

(A single facility for overhead electric lines means a single circuit)

Utility	Size	Width
Electric (Overhead Distribution & Transmission Single Circuits)	0-33 KV	20'
	34-100 KV	45'
	101-200 KV (pole)	75'
	101-200 KV (tower)	80'
	201-300 KV (tower)	125'
	300 KV & above (tower)	200'
Telephone cable or open wire when underbuilt	All	30'
Communications (Radio, Television, Telephone & Microwave)	All	30'
Active or passive microwave repeater and/or radio sites	All	40'
Microwave paths emanating from antennas or passive repeaters	All	20' from edges of antenna or passive repeater, and following centerline path.
Radio & Television antennas	All	30' in all directions

CALIFORNIA FOREST PRACTICE RULES

Telephone cable or open wire when underbuilt All 30'

(e) The above right-of-way widths for above ground facilities shall be allowed supplemental clearances as follows:

- (1) Equal additional rights-of-way for each additional facility, including these allowable supplemental clearances under this section.
- (2) Additional clearance widths for poles and towers, and for conductor sway as provided in PRC 4292 and 4293, and 14 CCR 1250 through 1258 inclusive, as applicable.
- (3) Additional clearance for removal of danger trees as defined in 14 CCR 895.1.
- (4) Additional land area for substation and switch yards, material storage and construction camps with clearance for firebreaks, and security fencing.

(f) TABLE OF RIGHTS-OF-WAY WIDTHS FOR SINGLE UNDERGROUND FACILITIES

Utility	Size	Width
Electric, Underground	4"-6" Conduit	50'
	More than 6" Conduit	60'
Gas, Oil, Water & Sewer (Underground pipe)	6" <u>diameter</u> or smaller	50'
	Over 6"-12" <u>diameter</u>	60'
	Over 12"-24" <u>diameter</u>	75'
	Over 24" <u>diameter</u>	100'
Penstocks, Siphons	All	100'
Ditches and Flumes	All	150'
Access Roads	All	Access road widths may be up to 14' with an additional 10' width at turnout locations, plus additional width for cuts and fills. Access roads shall be installed and maintained so as to comply with the stream protection requirements and erosion control requirements of the Forest Practice Act, related regulations, and the District Forest Practice Rules.

(g) The above right-of-way widths for underground facilities and penstocks, siphons, ditches and flumes shall be allowed supplemental clearances as follows:

- (1) Additional width for cuts and fills.
- (2) Removal of trees or plants with roots that could interfere with underground facilities, or with cuts and fills for installation.
- (3) Additional clearance for removal of danger trees as defined in 14 CCR 895.1.
- (4) For compressor, metering and control stations on natural gas pipelines; including firebreaks and security fencing:
 - (A) 450 foot width at one side of right-of-way and 500 foot length along the compressor stations.

CALIFORNIA FOREST PRACTICE RULES

(B) 300 feet x 300 feet on or alongside the right-of-way for metering and control stations.

(h) In-lieu practices for watercourse and lake protection zones as specified under Article 6 of these rules, exceptions to rules, and alternative practices are not allowed.

(i) Harvesting of large old trees shall only occur when:

(1) the tree is not critical for the maintenance of a Late Successional Stand and

(2) an RPF attaches to the exemption an explanation and justification for the removal based on the RPF's finding that one or more of the criteria or conditions listed under subsection (A), (B), or (C) are met.

The requirements of (i)(2) need not be met if an approved management document; including but not limited to a HCP, SYP, NTMP or PTEIR; addresses large old tree retention for the area in which the large old tree(s) are proposed for removal and the removal is in compliance with the retention standards of that document.

All trees to be harvested pursuant to this subsection shall be marked by an RPF prior to removal.

(A) The tree(s) is a hazard to safety or property. The hazard shall be identified in writing by an RPF or professionally certified arborist;

(B) The removal of the tree(s) is necessary for the construction of a building as approved by the appropriate county/city permitting process and as shown on the county/city approved site plan, which shall be attached to the Notice of Exemption;

(C) The tree is dead or is likely to die within one year of the date of proposed removal, as determined by an RPF or professionally certified arborist.

1104.2 Exemption for Conversion of Non-TPZ Land for Subdivision Development

Timber operations for the conversion of land not in the TPZ for subdivision development are exempt from this article, subject to all of the following conditions:

(a) The county board of supervisors or city council having jurisdiction has approved a tentative subdivision map pursuant to the Subdivision Map Act commencing with Gov. C. Sec. 66410.

(b) The county board of supervisors or city council having jurisdiction has granted required use permits and other necessary approvals.

(c) Before timber operations begin and before a THP is submitted, the timberland owner shall file a Notice of Exemption from Timberland Conversion Permit for Subdivision on a form prescribed by the Director.

The notice shall include, but need not be limited to, the following:

(1) Names and addresses of timberland owner(s), timber owner(s), and developer(s).

(2) Documentation that a Notice of Determination has been filed with the Office of Planning and Research pursuant to PRC 21108 or with the appropriate county clerk pursuant to PRC 21152.

(3) Estimated date of completion of the project.

(4) Acres of timberland to be converted.

(5) Legal property description of the conversion area.

(6) Signature, title, and date of signing of the timberland owner(s). In the case of a partnership, at least one of the partners shall sign the application. For a corporation, a corporate officer shall sign. In other cases of more than one owner, all owners shall sign. An agent may sign for the owner (s) if so designated in writing submitted with the Notice.

(7) Plat or map of the area to be converted.

(8) Documentation of the county or city tentative subdivision map approval, conditions of approval, required use permit, or other required county or city project approvals.

(d) Except as provided in this article, the applicable requirements of PRC 4511 through 4628 inclusive, PRC 5093.50 through 5093.68 inclusive, and all regulations adopted pursuant thereto shall apply to the timber operations.

(e) If the subdivision development project is not completed or is abandoned, the Director may take corrective action pursuant to PRC 4605-4611 to have restocked those parts of the area from which timber has been harvested and which do not meet the stocking requirements of this chapter. For purposes of this subsection, the project shall be deemed abandoned or not completed if:

(1) The county or city tentative map approval has expired; and

(2) No further work has been carried on to complete the subdivision for three years after the expected date of completion stated in the THP. The Director shall order inspections as needed to determine whether the project has been completed as proposed.

CALIFORNIA FOREST PRACTICE RULES

(f) Partial performance shall be recognized. Those portions of the subdivision shall be deemed completed and excluded from the stocking requirement where the development has been completed and residential services have been provided pursuant to the plan for development.

1104.3 Timberland Conversion Permit Fees

The applicant shall pay an application fee in the amount of \$600 [NOTE: The fee is \$700 if the land is zoned TPZ, see 1105.1. Also, there are DFG fees.] for the cost of processing an application for the conversion of timberland to a non-timber growing use. Where the land proposed to be converted lies within a TPZ the applicant shall also follow the requirements of Section 1105.1. The fee(s) shall be submitted with the application to the appropriate regional headquarters. Where actual state cost exceeds the application fee, the additional charge equal to the excess cost will be computed using State Administrative Manual Sections 8752.1 and 8740 (dated March 1990). The Department will keep the applicant informed of any additional charges and will advise the applicant of any estimated future costs. All additional charges shall be paid by the applicant to the Department's Accounting Office before the issuance of the Timberland Conversion Permit. Costs of recording the documents pursuant to this article shall be paid by the applicant.

1105 Application

The conversion permit application shall be in a form prescribed by the Director and shall require but not be limited to the following information:

The name and address of the applicant;

The name and address of the timberland owner of record;

The name and address of the timber owner;

The legal description, general plan designation, and zoned status of the proposed conversion area;

The proposed future use or uses of said area;

The dates when conversion is to be commenced and completed;

The approximate number of acres to be converted;

The zoned status of adjacent property;

A description of other land owned by the applicant in the surrounding area which could accommodate the proposed use or used;

Together with a copy of the conversion plan.

The application shall be executed under penalty of perjury.

1105.1 Application Fees

In addition to the requirements of Section 1104.3, the applicant shall pay a fee in the amount of \$100 for the cost of processing an application for conversion where the land proposed to be converted lies within a TPZ. [NOTE: The total of CDF fees is \$700. There may be additional fees from DFG.] Fees for the recording of documents pursuant to this article shall be borne by the applicant.

1105.2 Director's Determination

The Director shall determine the applicant's bona fide intention to convert in light of the present and predicted economic ability of the applicant to carry out the proposed conversion; the environmental feasibility of the conversion, including, but not limited to, suitability of soils, slope, aspect, quality and quantity of water, and micro-climate; adequacy and feasibility of possible measures for mitigation of significant adverse environmental impacts; and other foreseeable factors necessary for successful conversion to the proposed land use.

1105.3 Conversion Plan

A conversion plan in a form prescribed by the Director shall become a part of the application. The plan conversion shall set forth in detail information pertaining to present and future use, soils, topography, conversion techniques, conversion time schedule and such other information as may be required and is applicable to the particular future use to which the land will be devoted.

CALIFORNIA FOREST PRACTICE RULES

1105.4 Additional Proof

The Director or the Board upon appeal may require that the applicant provide such further or additional proof or information as in the Director's or Board's judgment is necessary to allow him to decide whether or not to issue a conversion permit pursuant to PRC 4621.2 and 4623.

1106 Conversion Permit Issuance

- (a) The Director shall issue a conversion permit if:
- (1) In his judgment the bona fide intent of the applicant to convert is established;
 - (2) He makes the written findings pursuant to PRC 4621.2, when applicable;
 - (3) He makes the written findings pursuant to PRC 21081, if an environmental impact report has been prepared;
 - (4) He finds that necessary and feasible mitigation measures have been incorporated into the proposed conversion; and
 - (5) He finds that no other proximate and suitable land not within a TPZ is available for the proposed alternative use for lands within a TPZ, if PRC 4621.2 applies.
- (b) The Board upon appeal shall apply the same standards as the Director in subsection (a) above in determining whether to issue a conversion permit.

1106.1 Contents of Conversion Permit

The conversion permit shall include, but not be limited to, the name of the permittee, identification of code section of the forest practice rules and regulations from exempt, description of the lands to which the conversion permit is applicable, and the period of time during which the conversion permit is valid.

1106.2 Timber Harvesting Plan Processing

Prior to the start of timber operations, the applicant shall submit to the Director a Timber Harvesting Plan applicable to timber operations set forth in the conversion plan. The THP may be submitted concurrently with the Timberland conversion Permit application but the Director may not approve the THP until the Timberland Conversion Permit is issued.

1106.3 Recordation, Renewal, Transferability

- (a) The permittee shall submit the conversion permit to the County Recorder for recording in each county in which the property is located before beginning any operations contemplated under said permit. Amendments, suspensions, revocations, and cancellations of conversion permits shall be recorded in the same manner.
- (b) A conversion permit may be renewed by the Director upon a proper showing of cause and necessity by the permittee. The Director may deny renewal and require a new application if he finds that circumstances have substantially changed.
- (c) The privilege granted to the permittee is nontransferable and nonassignable for any purpose without written approval of the Director.

1106.4 Conversion Permit Denial

- (a) The Director shall deny a conversion permit:
- (1) For any of the reasons set forth in PRC 4624;
 - (2) If, in the Director's judgment, the applicant has failed to provide satisfactory proof of his bona fide intent to convert;
 - (3) If the Director cannot make the findings required by PRC 21801, if an environmental impact report has been prepared;
 - (4) If the Director finds that necessary and feasible mitigation measures have not been incorporated into the proposed conversion; or
 - (5) For lands within a TPZ, if PRC 4621.2 applies and the Director finds that other proximate and suitable land not within a TPZ is available for the proposed alternative use.
- (b) The Board upon appeal shall deny a conversion permit for any of the reasons specified in subsection (a) above.

CALIFORNIA FOREST PRACTICE RULES

1106.5 Denial, Suspension, Revocation

(a) Except as provided in subsection (b), the Director may deny, suspend or revoke a conversion permit in accordance with the requirements of Article 9 (commencing with Sec. 4621) of Chapter 8, Part 2, Division 4 of the PRC, provided that all proceedings in connection with such action shall be conducted in accordance with the provisions of Chapter 5 (commencing with Sec. 11500) of Part 1, Division 3, Title 2 of the Gov. C.

(b) The Director may deny a conversion permit pursuant to PRC 4621.2(d) provided that all proceedings in connection with such action shall be conducted in accordance with the provisions of subsection (a) above, except that the applicant must request a hearing before the Board within 15 days of service of the denial. The hearing shall be commenced within 60 days from the filing of the appeal unless a later hearing date is mutually agreed upon by the applicant and the Board.

1107 Cancellation by Permittee

Upon application by the permittee for cancellation, the conversion permit may be cancelled by the Director upon such terms and conditions as he may set forth. Upon cancellation of the conversion permit, an agreement of cancellation, executed by the permittee and the Director, shall be recorded by the permittee in those counties in which the permit was originally recorded. Upon such recording, the subject land shall revert back to timberland and stocking shall be established pursuant to PRC 4561 and 4561.3. The Director shall provide a copy of the cancellation agreement to the county assessors and the county planning directors of those counties in which the property is located.

1108 Coastal Zone Conversion

A timberland conversion permit is required for conversion of coastal commercial timberland to uses other than the growing of timber. Except as hereafter provided, conversion of any such timberland shall be limited to providing for necessary timber processing and related facilities.

The Director, or the Board upon appeal, may approve conversion of coastal commercial timberland for other than necessary timber processing and related facilities only if all of the following conditions are met:

- (a) Such conversion will not introduce new uses or significantly intensify existing uses that are incompatible with timber growing on areas adjacent to the area proposed for conversion, or that have a substantial adverse impact on coastal resources, as determined by the Director, and
- (b) The area proposed for conversion is in a unit of noncommercial size as determined by the California State Coastal Commission or the zoning in a certified local coastal plan; and
- (c) The conversion complies with all other applicable laws, rules, and regulations.

1109 Immediate Rezoning

Immediate rezoning of land within a TPZ shall be accomplished in compliance with one of the two procedures set forth in 14 CCR 1109.1 and 1110.

1109.1 City or County Tentative Approval

When a county Board of Supervisors or City Council tentatively approves an immediate rezoning pursuant to Gov. C. 51133, for which a conversion permit is also required, it shall forward the following to the Director: documentation of its tentative approval upon a four-fifths vote of the full body; copies of the Notices sent to landowners within one mile (1.61 km) of the exterior boundary of the land upon which immediate rezoning is proposed, and the formal findings that immediate rezoning is not inconsistent with the purpose of subdivision (j) of Sec. 3 of Article XIII of the State Constitution, and findings that rezoning is in the public interest, as required by Gov. C. 51133(a); minutes of public hearing(s), including hearings held by the appropriate local planning agency pursuant to the application for immediate rezoning and any related applications for local government general plan land use category change, conditional use permit, or other entitlement for use; copies of documents, plans, maps, and photographs submitted in conjunction with the said public hearing(s); and copies of completed environmental documentation submitted pursuant to the application for immediate rezoning.

Upon the receipt of the foregoing materials, the completed conversion application and conversion plan, and such further information as may be required, the Director shall determine whether or not to approve the conversion pursuant to PRC 4621.2. Upon approval of the conversion by the Director or by the Board upon appeal, the Director shall so notify the county Board of Supervisors or City Council, who may then finalize

CALIFORNIA FOREST PRACTICE RULES

the immediate rezoning.

1109.2 Public Interest

In determining whether or not to make the written finding contained in PRC 4621.2(a)(1), the Director or the Board upon appeal shall consider the following elements of public interest:

(a) Whether the alternative use will serve a public need; provide a public service; benefit the local community and region, including economic and social benefits; avoid damage or threatened damage to other property, especially public parks and other publicly-owned lands; or involve costs and secondary impacts caused by services required by the alternative use.

(b) The adverse environmental impacts of the alternative use and mitigation thereof. Impacts shall include, but not be limited to, impacts on lakes, streams, and other waters; wildlife; air quality; and aesthetics.

(c) The impact on the long term timber supply capability of California, including the cumulative impact from conversion of similar properties.

(d) The availability of proximate and suitable land to accommodate the alternative use which lies outside of a TPZ or which would involve the removal of lower quality timberlands from productive use.

1109.3 No Substantial and Unmitigated Adverse Effect Upon Other Timberland Production Zones Within One Mile (1.609 km)

In determining whether or not to make the written finding contained in PRC 4621.2(a)(2), the Director or the Board upon appeal shall consider such adverse factors as increased fire hazard and risk, forest pest potential, mass land movement, gully and sheet erosion, increased windthrow, shock to nearby stands from exposure, harmful fumes, emissions, dust, discharge of waste or chemicals, unconfined grazing of livestock, diversion or impoundment of water, wildlife use changes damaging to other properties, and other potential adverse factors.

1109.4 Suitability of Soils, Slopes, and Watersheds

In determining whether or not to make the written finding contained in PRC 4621.2(a)(3), the Director or the Board upon appeal shall consider the following elements: whether the soil types and characteristics can support the proposed use, the erosion potential of the soils and slopes in light of the proposed use, potential mass land movement or subsidence possible harm to quality or quantity of water produced in the watershed, fire hazard and risk to the watershed, adverse effects to fish and wildlife from removal of habitat cover, and such other elements as appropriate.

1109.5 No Other Reasonable or Comparable Timber Growing Use

In determining pursuant to PRC 4621.2(c) whether or not timberlands within a TPZ that are the subject of a conversion application may be put to another reasonable or comparable timber-growing use, the Director or the Board upon appeal shall consider timber stand volume, timber growth rate, timber site and soil, climate, potential markets, any other relevant factors.

1109.6 Supplemental Data and Opinions

As an aid to the Director or the Board upon appeal in making the findings and approving the proposed conversion pursuant to PRC 4621.2, the Director or the Board upon appeal may upon their own initiative consult with or request reports from appropriate experts. The Director or the Board upon appeal may also require the applicant to furnish appropriate and necessary information or documentation, including that from appropriate expert consultants at the applicant's expense.

1110 Conversion Permit Within TPZ Not Required

Requests for immediate rezoning for an area exempted from this article pursuant to 14 CCR 1104.1 shall be processed in accordance with Gov. C. 51134.

CALIFORNIA FOREST PRACTICE RULES

CHAPTER 4.5 Hearings [in Rule Counties]

Detailed Analysis Section

1115 Time for Request

The board of supervisors or planning commission of any county for which rules have been adopted pursuant to Sec. 4516.5 of the PRC may request a public hearing on any timber harvesting plan or non-industrial timber management plan submitted for lands within the county. Such request must be made no later than one (1) calendar day after the pre-harvest inspection date. The request may be in writing, by phone, or by facsimile. The request must be for a specific plan that has been filed according to 14 CCR 1032. For good cause, the Director may extend the deadline.

1115.1 Scheduling

Upon receipt of a request pursuant to 14 CCR 1115, the Department shall schedule a public hearing to be held no more than twenty-five (25) and no less than five (5) calendar days from the date of the request.

1115.2 Notification

The Department shall notify the public of the fact that such a public hearing will be held. The notice shall include information on the time and location of the hearing. The notice shall be given at least five (5) days before the date that the public hearing will be held. At a minimum, a copy of the notice shall be mailed to the county requesting the hearing, the Review Team members, and other interested parties as identified pursuant to 14 CCR 1032.7(e), and publishing a copy of the notice in a newspaper of general circulation in the area.

1115.3 Conduct of Hearing

The Department shall conduct a public hearing upon timely request. A Department representative shall conduct the hearing. The Departmental representative should be familiar with the THP or Non-Industrial Timber Management Plan under review. The purpose of the public hearing is to gather information from the public regarding the proposed timber operation. The public hearing is considered to be an integral part of the multidisciplinary review of the THP or NTMP. The comments of the public shall be electronically recorded by the Department, and may be recorded by any person present. No departmental action with regard to the approval or disapproval of a timber harvesting plan or Non-Industrial Timber Management Plan shall occur at the public hearing. The Department representative that conducted the hearing shall submit a written report of the hearing to the Departmental employee responsible for approval or disapproval of the plan. The Department shall provide written responses to significant issues raised at the public hearing in the official response of the director required by 14 CCR 1037.8.